

# ECCENTRIC DISC SANDER

## 3 601 C87 010 ROS10

20.02.2008 16:09:48

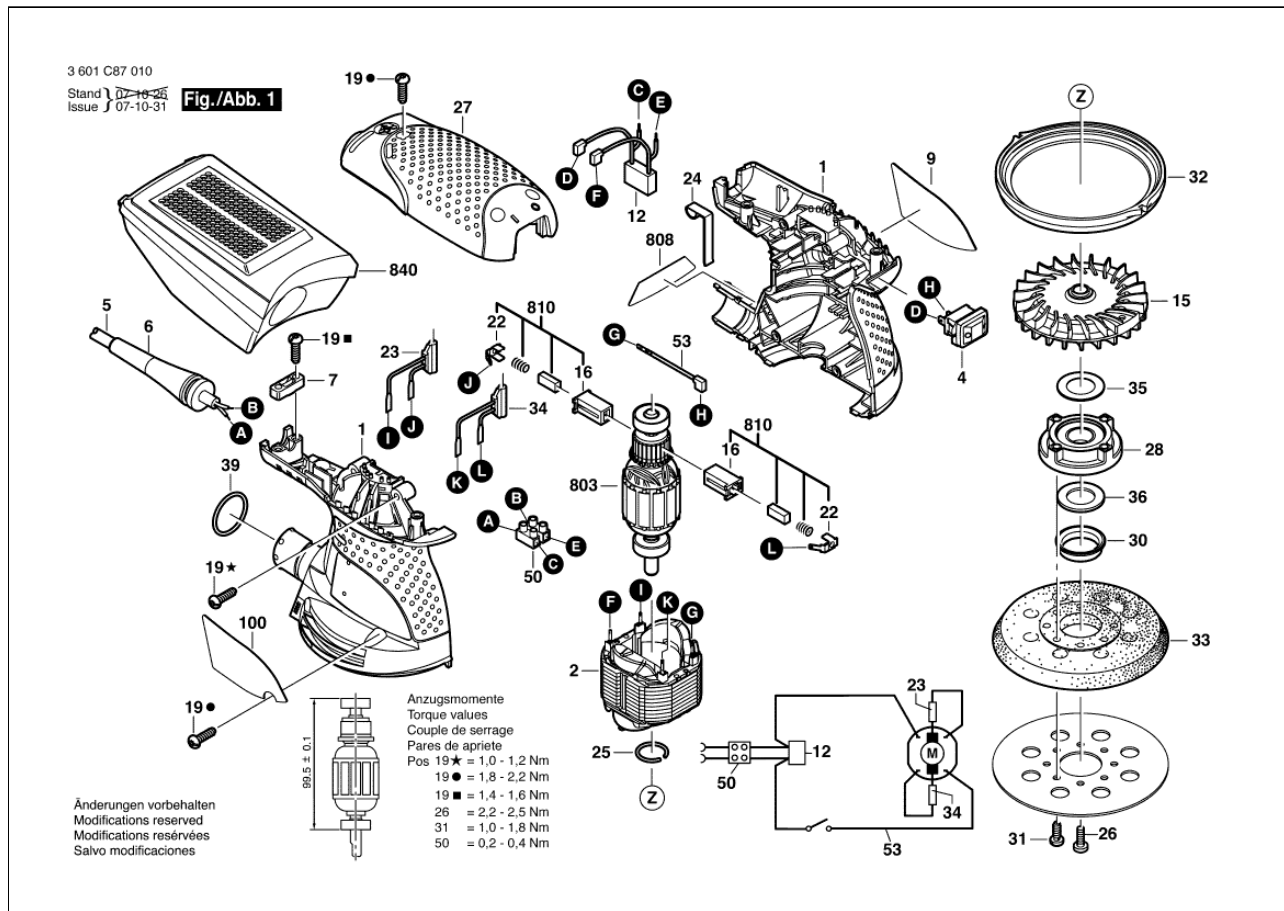

Item	Quantity	Order No.	Designation	Price group	Page
1	1	2 609 100 614	HOUSING	29	1
2	1	2 609 120 195	FIELD / 120V	30	1
4	1	1 607 200 190	ON-OFF SWITCH	22	1
5	1	2 604 460 186	POWER SUPPLY CORD / USA/CDN 2,68m 2 x 082mm SJ 18/2	26	1
6	1	2 600 703 018	GROMMET / Ø7,3-Ø8,6x76MM	13	1
7	1	2 601 035 001	CABLE CLIP	11	1
9	1	2 609 131 386	MANUFACTURER'S NAMEPLATE	13	1
12	1	2 609 120 298	SUPPRESSION CAPACITOR	18	1
15	1	2 609 110 637	FAN	35	1
16	2	2 610 320 548	CARBON BRUSH HOLDER	13	1
19	9	2 603 490 022	TORX OVAL-HEAD SCREW / M 4x16	10	1
22	1	2 610 329 896	TERMINAL	11	1
23	1	2 609 120 290	INDUCTOR	15	1
24	1	2 601 329 043	CONTACT STRAP	11	1
25	1	2 916 540 005	RETAINING RING / DIN 7993-A8	10	1
26	1	2 610 918 116	SCREW AND WASHER ASSEMBLY	15	1
27	1	2 609 100 616	HOUSING COVER	23	1
28	1	2 609 100 661	BEARING FLANGE	23	1
30	4	2 609 100 633	COVER	12	1
31	4	2 610 915 161	SCREW	15	1
32	1	2 609 170 071	FRICTION RING	11	1
33	1	2 609 100 541	RUBBER BACKING PAD	29	1
34	1	2 609 120 291	INDUCTOR	15	1
35	1	2 609 110 724	WASHER	11	1
36	1	2 609 170 084	FELT WASHER	11	1
39	1	1 610 210 045	O-RING / 3x23 MM	11	1
50	1	2 610 910 009	CONNECTION BLOCK	12	1

53	1	2 609 120 284	CONNECTING CABLE	12	1
100	1	2 609 131 561	WARNING PLATE	13	1
677	1	2 610 907 746	ADAPTER	20	0
803	1	2 609 199 166	ARMATURE / 120V	41	1
808	1	2 609 131 735	TYPE IDENTIFYING MARK	13	1
810	1	2 609 120 199	CARBON-BRUSH SET	22	1
840	1	2 609 199 179	DUST CONTAINER	28	1