

# Refrigerator

## FCFS201LF B

19.53 Cu. Ft. Commercial,  
Food Service Grade



### Signature Features

Dynamic Condenser Improves Performance In Higher Temperature Environments

Heavy-Duty, Locking Casters

Heavy-Duty, NSF®-Certified Stainless Steel Shelves

NSF®-Certified For Food Service Applications

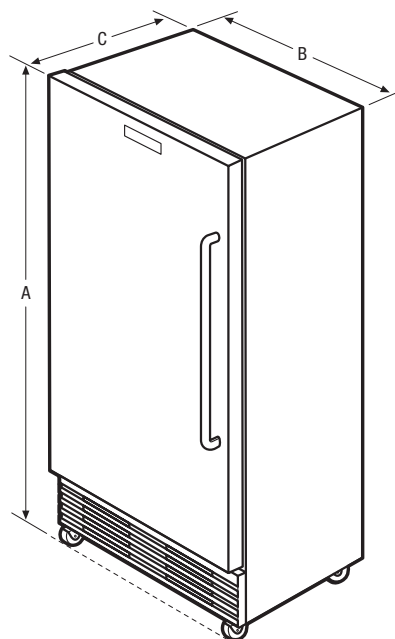

### Product Dimensions

A - Height (Including Casters)	74-3/4"
B - Width	32"
C - Depth (Including Door)	28-5/8"
Depth with Door Opened 90°	59-1/4"

### More Easy-To-Use Features

NSF®-Certified Interior Lighting System

NSF®-Certified Stainless Steel Handle

NSF®-Certified Temperature Gauge

Sealed Cabinet Interior For Easy Cleaning

Stainless Steel Door

Stainless Steel Evaporator Cover

### Accessories

Top Shelf - White	216382202
Deep Shelf - White	216384002
Trivet - White	216331802
Shelf Support Clips	216605300 (4 Required)
18" X 26" Pan Rack Kit <sup>1</sup>	PANRACKKIT

### Specifications

Total Capacity (Cu. Ft.)	19.53
Power Supply Connection Location	Right Bottom Rear
Voltage Rating	120V / 5A
Shipping Weight (Approx.)	273 Lbs.

ENERGY STAR®  
NSF® International Certification



### Available in:



<sup>1</sup>Holds 8 Sheet Pans, Two Kits for Entire Cabinet Length, holds up to Two Kits.

<sup>2</sup>Stainless Steel Door/Black Cabinet.

Accessories information available on the web at [frigidairecommercial.com](http://frigidairecommercial.com)

