

# Refrigerator

FCGM201RF B

19.7 Cu. Ft. Commercial,  
Food Service Grade



## Signature Features

Dual-Pane, Argon Gas-Filled  
Glass Display Door

Dynamic Condenser Improves  
Performance In Higher  
Temperature Environments

Heavy-Duty Cooling System,  
NSF®-Certified Performance

Heavy-Duty, Locking Casters

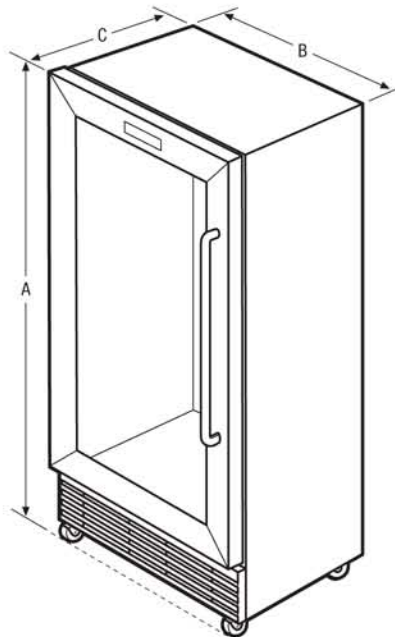

### Product Dimensions

A - Height (Including Casters)	74-3/4"
B - Width	32"
C - Depth (Including Door)	27-5/8"
Depth with Door Opened 90°	59-1/8"

### More Easy-To-Use Features

Heavy-Duty, NSF®-Certified  
Stainless Steel Shelves

NSF®-Certified For Food Service  
Applications

NSF®-Certified Interior Lighting  
System

NSF®-Certified Stainless Steel  
Handle

NSF®-Certified Temperature Gauge

Sealed Cabinet Interior For Easy  
Cleaning

Stainless Steel Evaporator Cover

### Accessories

Top Shelf - White	216681903
Center Shelf - White	216682002
Trivet - White	216681802
Shelf Support Clips	297121900 (4 Required)
18" X 26" Pan Rack Kit <sup>1</sup>	PANRACKKIT

### Specifications

Total Capacity (Cu. Ft.)	19.7
Power Supply Connection Location	Right Bottom Rear
Voltage Rating	120V / 5A
Shipping Weight (Approx.)	309 Lbs.



NSF® International Certification

### Available in:



<sup>1</sup>Holds 8 Sheet Pans, Two Kits for Entire Cabinet  
Length, holds up to Two Kits.

<sup>2</sup>Stainless Steel and Glass Door/  
Black Cabinet.

Accessories information available on  
the web at [frigidairecommercial.com](http://frigidairecommercial.com)

