



GENERAL DESCRIPTION:

Exposed, sensor-operated Selectronic® Toilet Flush Valve for floor-mounted or wall-hung 1-1/2" top spud flushometer bowls. CR-P2 lithium battery powered.

PRODUCT FEATURES:

- **Factory-Installed CR-P2 Lithium Battery**
- **Selectronic® Proximity System** with universal sensor provides hygienic, "hands free" operation
- **State-of-the-Art Electronics** prevent ghost flushing
- **Dezincification Resistant** semi-red brass alloy
- **Fully Mechanical Manual Override Button** can flush the valve without power
- **Fail-Safe:** Valve automatically closes upon loss of power or water pressure and does not need to be reset
- **Adjustable Sanitary Flush** cleans the fixture & maintains the trap seal.
- **Stadium Feature:** Valve automatically switches to water savings mode during periods of heavy usage
- **Chemical Resistant EPDM Seals** for extended life
- **High Back Pressure Vacuum Breaker**
- **Adjustable Tailpiece**
- **Range can be adjusted manually or with optional remote control**
- **No external volume adjustment.**
- **Can be installed left or right handed**

MODEL NUMBER:

- ☐ **6065.111.002** Exposed, sensor-operated flush valve for 1-1/2" top spud flushometer bowls, 1.1 gpf.

Inlet includes 1" sweat solder kit and angle stop with back flow protection and vandal-resistant cap.

Outlet includes 1-1/2" high back pressure vacuum breaker with spud coupling and flange.

OPERATING PRESSURE:

Overall Range: 20-125 psi**

Recommended: 25 psi (flowing) - 80 psi (static)

** Water pressure over 80 psi is not recommended for most plumbing fixtures.

FLOW REQUIREMENT:

25 gpm (94.6 L/min.)

BATTERY LIFE:

4 years

OPTIONAL ACCESSORIES:

- Cast wall flanges: 1" (6065.810) & 1-1/2" (6065.815)
- Solid ring pipe supports: 2-1/2" C-E (6065.821) & 6" C-E (6065.861)
- Split ring pipe supports: 2-1/2" C-E (6065.822) & 6" C-E (6065.862)

**TYPICAL WATER CLOSET INSTALLATION:
AFWALL™ TOILET SHOWN**

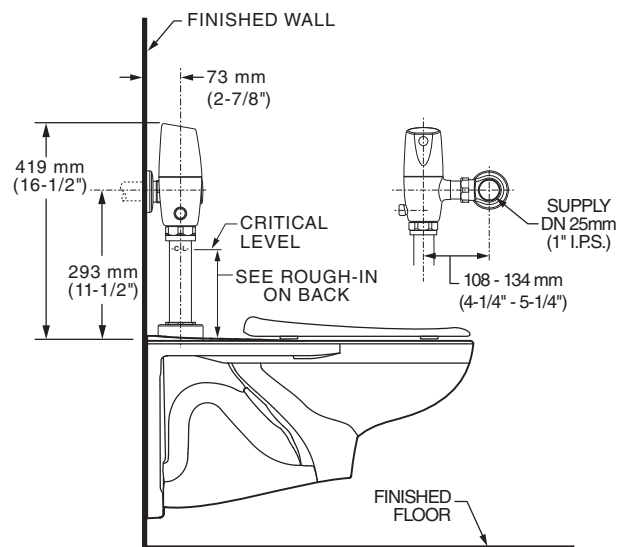

RECOMMENDED SPECIFICATION:

Electronic, sensor activated toilet flush valve shall feature self-cleaning piston valve with integral wiper spring in refill orifice to prevent clogging. Includes a factory-installed CR-P2 lithium battery and fully mechanical manual override that can flush the valve without power. Includes semi-red brass valve body and metal cover with chrome finish. Includes angle stop with back-flow protection & vandal-resistant cap. Sweat solder kit and high back pressure vacuum breaker also included. 1.1 gpf / 4.2 Lpf flush valve shall be American Standard Model # 6065.111.002.

LISTINGS:

- ASSE 1037
- ANSI/ASME A112.19.2
- ADA Compliant

Roughing-in Dimensions

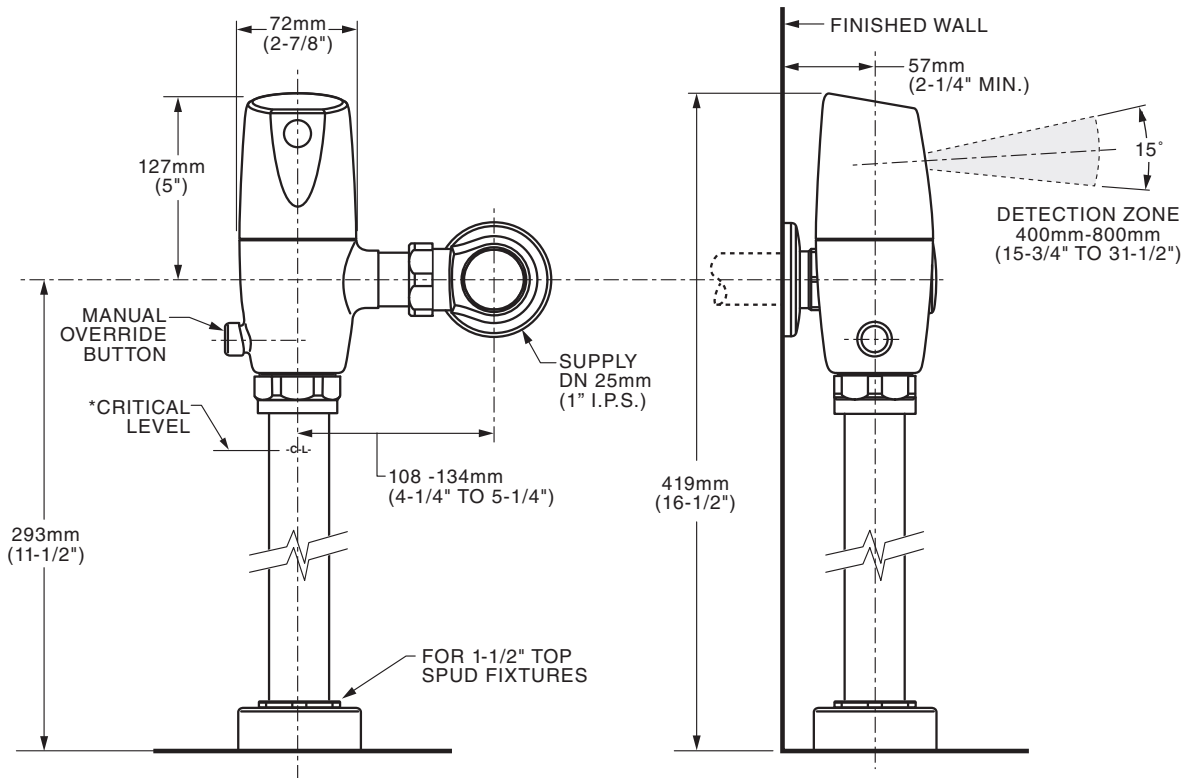

*Note: The Critical Line (-C-L-) on Vacuum Breaker must typically be 6" (152mm) above fixture. Consult Codes for details.

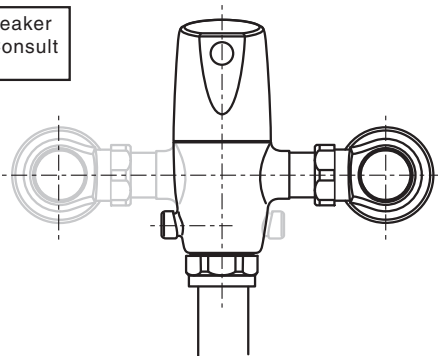

Right or Left Hand Installation

NOTICE:

To ensure proper performance, this 1.1 gpf (4.2 Lpf) Toilet Flush Valve must be installed on a flushometer bowl that is certified (per ASME A112.19.2/CSA B45.1) to operate at 1.1 gpf (4.2 Lpf).

 **MEETS THE AMERICANS WITH DISABILITIES ACT GUIDELINES AND ANSI A117.1 REQUIREMENTS FOR ACCESSIBLE AND USABLE BUILDING FACILITIES-CHECK LOCAL CODES**