

Antero's surfaces flow together in a stunning and sophisticated look that anyone would be proud to have in their kitchen. Modern features such as the quiet Captur™ system, LED lighting and capacitive touch controls make it a pleasure to use.

| SIZE | WHITE | BLACK | STAINLESS | GREASE FILTER(S) (replacement) | NON-DUCTED FILTER(S) |
|---------|-----------|-----------|-----------|-----------------------------------|-------------------------|
| 30-in. | CLDA130WW | -- | CLDA130SS | HPFAMM30 (Type C2) | HPF30 (Type Xc) |
| 36-in.* | CLDA136WW | CLDA136BL | CLDA136SS | HPFAMM36 (Type D2) | HPF36 (Type Xd) |

* Not available in Canada.

| PERFORMANCE | | | | | | | | | |
|--------------------------|-----------------|-----------------|--------|--------|------|--------------|--------|------|--|
| Duct Orientation | Size | Damper | Sones | | | CFM @ 0.1 Ps | | | |
| | | | Normal | Medium | High | Normal | Medium | High | |
| Vertical - Rectangular | 3¼-in. x 10-in. | Included | 1.5 | 3.0 | 5.0 | 140 | 180 | 230 | |
| Horizontal - Rectangular | 3¼-in. x 10-in. | Included | 1.5 | 3.0 | 5.0 | 110 | 150 | 210 | |
| Round - Vertical | 7-in. | Sold Separately | 1.5 | 3.0 | 5.0 | 150 | 190 | 250 | |

| FEATURES | |
|-----------------------|--------------------------------------|
| Control type | 3-speed Capacitive Touch |
| Delay off | no |
| Filter Clean Reminder | yes |
| Heat Sentry™ | no |
| ADA Capable | yes |
| Lighting | 2-level LED (included) |
| Grease Filter(s) | Micro Mesh (Qty. 2) |
| Installation Hardware | EZ1 brackets |
| ENERGY STAR® | no |
| Recirculation | Non-ducted filter(s) sold separately |

| AC INPUT | |
|-------------------------|--|
| 120V, 60 Hz - 0.65 AMPS | |

| OPTIONAL ACCESSORIES | |
|----------------------|--------------------------------|
| 7-in. Round Damper | BP87 |
| ADA Wiring Kit | HAWRK3 (Available April, 2017) |



| MOUNTING HEIGHT | |
|---|--|
| 18-in. to 24-in. from cooktop to bottom of hood | |

| LIMITED WARRANTY | |
|---|--|
| 1-year | |
| 3-year (LED modules only) | |
| See installation manual for full warranty text. | |

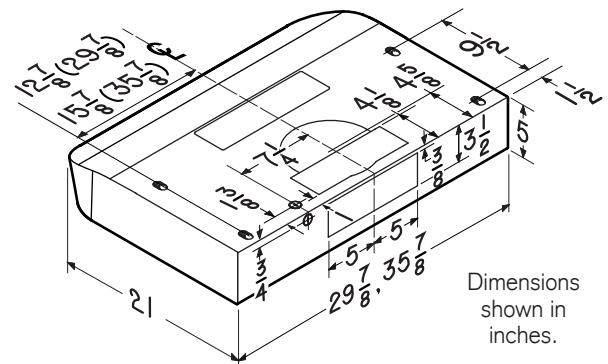
FOR INDOOR USE ONLY



Dimensions shown in inches.

| 30-IN. WIDTH HOODS | 36-IN. WIDTH HOODS |
|--|---|
|  |  |

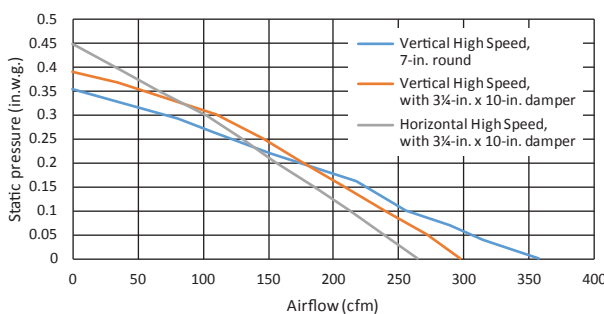

HVI-2100 CERTIFIED RATINGS comply with new testing technologies and procedures prescribed by the Home Ventilating Institute, for off-the-shelf products, as they are available to consumers. Product performance is rated at 0.1 in. static pressure, based on tests conducted in AMCA's state-of-the-art test laboratory. Sones are a measure of humanly-perceived loudness, based on laboratory measurements.

99045763B

Broan-NuTone LLC | 926 West State Street, Hartford, WI 53027 | 1 800-558-1711 | www.broan.com
 Broan-NuTone Canada ULC | 1140 Tristar Drive Mississauga, Ontario Canada L5T 1H9 | 1 888-882-7626 | www.broan.ca

Les surfaces d'Antero se fondent en un style superbe et raffiné qui fera la fierté de votre cuisine. Des caractéristiques d'avant-garde comme le système silencieux Captur^{MC}, l'éclairage à DEL et la commande capacitive en font un plaisir à utiliser.

| LARGEUR | BLANC | NOIR | INOX | FILTRE(S) À GRAISSES (remplacement) | FILTRE(S) DE RECIRCULATION |
|---------|-----------|-----------|-----------|-------------------------------------|----------------------------|
| 30 po | CLDA130WW | -- | CLDA130SS | HPFAMM30 (Type C2) | HPF30 (Type Xc) |
| 36 po * | CLDA136WW | CLDA136BL | CLDA136SS | HPFAMM36 (Type D2) | HPF36 (Type Xd) |

* non offert au Canada

| RENDEMENT | | | | | | | | |
|--------------------------|---------------|------------------|---------|---------|-------|-------------------------------|---------|-------|
| Orientation du conduit | Largeur | Volet | Sones | | | pi ³ /min @ 0,1 Ps | | |
| | | | Normale | Moyenne | Haute | Normale | Moyenne | Haute |
| Rectangulaire vertical | 3¼ po x 10 po | inclus | 1,5 | 3,0 | 5,0 | 140 | 180 | 230 |
| Rectangulaire horizontal | 3¼ po x 10 po | inclus | 1,5 | 3,0 | 5,0 | 110 | 150 | 210 |
| Rond vertical | 7 po | vendu séparément | 1,5 | 3,0 | 5,0 | 150 | 190 | 250 |

| CARACTÉRISTIQUES | |
|-------------------------------------|--|
| Type de commande | Capacitive, à 3 vitesses |
| Arrêt différé | non |
| Rappel d'entretien des filtres | oui |
| Détecteur Heat Sentry ^{MC} | non |
| Capacité ADA | oui |
| Éclairage | DEL à 2 intensités (inclus) |
| Filtre(s) à graisses | À maillage fin (qté 2) |
| Matériel pour l'installation | Supports EZ1 |
| ENERGY STAR [®] | non |
| Recirculation | Filtres de recirculation vendus séparément |

ALIMENTATION CA
120 V, 60 Hz - 0,65 AMPS

| ACCESSOIRES OPTIONNELS | |
|-------------------------|-----------------------------|
| Volet rond de 7 po | BP87 |
| Ensemble de câblage ADA | HAWRK3 (offert avril, 2017) |

HAUTEUR DE MONTAGE
De 18 po à 24 po au-dessus de la surface de cuisson

GARANTIE LIMITÉE
1 an
3 ans (modules DEL seulement)
Voir le manuel d'installation pour le texte complet de la garantie.

POUR UTILISATION À L'INTÉRIEUR SEULEMENT

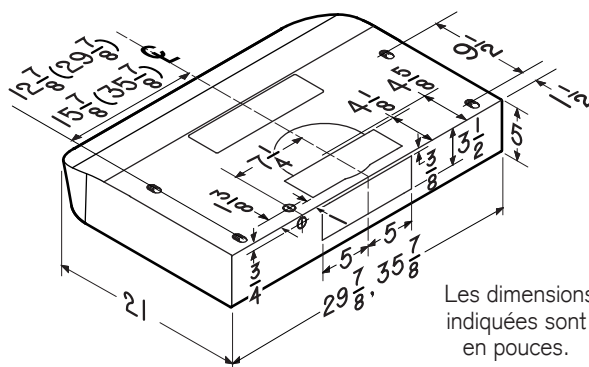

| HOTTES DE 30 PO DE LARGEUR | HOTTES DE 36 PO DE LARGEUR |
|----------------------------|----------------------------|
| | |

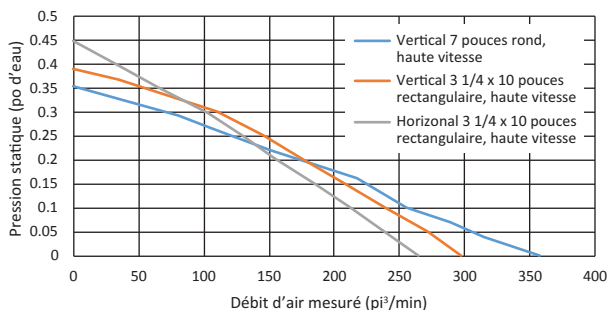

L'HOMOLOGATION HVI-2100 est conforme aux nouvelles techniques et procédures d'essai prescrites par le Home Ventilating Institute pour les produits d'emploi courant, dès leur disponibilité pour les consommateurs. Le rendement du produit est évalué à une pression statique de 0,1 po, d'après les tests effectués dans le laboratoire d'essai ultra-perfectionné de l'AMCA. Le sone est une mesure de la perception humaine de la puissance sonore, d'après des mesures effectuées en laboratoire.