

# 60" CAST IRON ROLL TOP TUB W/7" DECK HOLES

Cat. No.  
CTR7H60



L: 60 3/4"  
W: 30 1/2"  
H: 23 1/4" (from floor to top of tub)  
18 5/8" (from bottom of tub to top of tub)



Meets or exceeds the following specifications: A112-19-1M 1994.

### The following is recommended for CTR7H60 tubs:

- Rim-mounted faucet: part #4601
- Straight bath supplies: part #5577
- Leg tub drain: part #5599
- For use with shower curtain rod:  
Part# 4062, 4045
- Complete shower unit: Part# 4063

Gallon Capacity:	40
Shipping Weight:	500 lbs.
Empty Weight:	287 lbs.
Filled Weight:	622 lbs.

## Features:

- ▶ Inside finish is white enamel
- ▶ Cast Iron ball and claw feet available in 6 finishes or unfinished
- ▶ Tub exterior is white (epoxy)
- ▶ 7" centers in tub deck
- ▶ Non-skid strips
- ▶ Feet are attached and leveled before shipment
- ▶ Tub is thoroughly inspected before shipment

### Foot Finishes:

- BP Polished Brass
- CP Polished Chrome
- PN Polished Nickel
- SN Brushed Nickel
- WH White
- ORB Oil-rubbed Bronze



**Custom Colors Available** (inside of tub is always white enamel):  
Painted bathtubs are considered "special order" and are not returnable  
\$160 Bisque or Black \$250 Designer Color

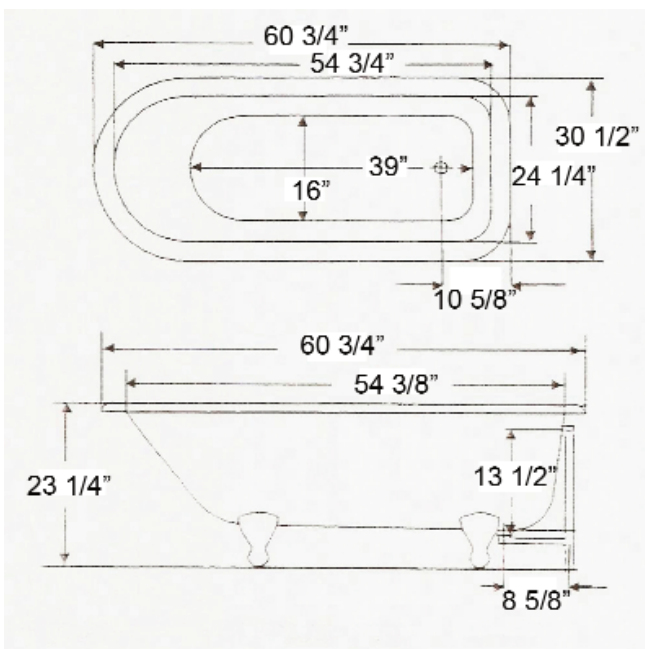

Dimensions of fixture are nominal and may vary within the range of tolerances established by ANSI Standard A112.19.2. Dimensions and specifications subject to change without notice.