

68" CAST IRON ROLL TOP TUB

Cat. No.
CTRN67



L: 68"
W: 30 1/2"
H: 23 1/4" (from floor to top of tub)
18 5/8" (from bottom of tub to top of tub)

Meets or exceeds the following specifications: A112-19-1M 1994.

The following is recommended for CTRN67 tubs without faucet holes:

- Faucets: part #4602
- Rigid, freestanding supplies: part #4502
- Leg tub drain: part #5599

Gallon Capacity: 57
Shipping Weight: 502 lbs.
Empty Weight: 309 lbs.
Filled Weight: 787 lbs.

Features:

- ▶ Inside finish is white enamel
- ▶ Ball and claw feet available in 6 finishes or unfinished
- ▶ Tub exterior is white (epoxy)
- ▶ No faucet holes
- ▶ Non-skid strips
- ▶ Feet are attached and leveled before shipment
- ▶ Tub is thoroughly inspected before shipment

Foot Finishes:

- BP Polished Brass
- CP Polished Chrome
- PN Polished Nickel
- SN Brushed Nickel
- WH White
- ORB Oil-rubbed Bronze



Custom Colors Available (inside of tub is always white enamel):
Painted bathtubs are considered "special order" and are not returnable
\$160 Bisque or Black \$250 Designer Color

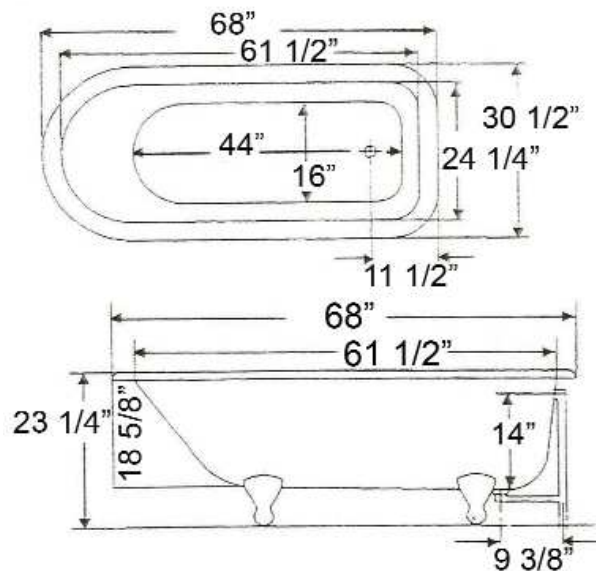

Dimensions of fixture are nominal and may vary within the range of tolerances established by ANSI Standard A112.19.2. Dimensions and specifications subject to change without notice.