

# 71" CAST IRON DOUBLE SLIPPER TUB

Cat. No.  
CTDSN



L: 71"  
W: 30 1/2"  
H: 30" (from floor to top of tub)  
22" (from floor to lowest tub rim)  
18 1/2" (from bottom of tub to top center of tub)  
26 3/4" (from bottom of tub to top of tub)

Water depth: 14 1/4" to OF

### Toe to Toe Measurements:

35" Front to back  
20-1/2" Side to side

### The following is recommended for CTDSN tubs without faucet holes:

- Faucets: part #4602
- Rigid, freestanding supplies: part #4502
- Leg tub drain: part #5599

Gallon Capacity: 43 1/2  
Shipping Weight: 544 lbs.  
Empty Weight: 364 lbs.  
Filled Weight: 728 lbs

### Features:

- ▶ Inside finish is white enamel
- ▶ Cast Iron lion feet available in 6 finishes or unfinished
- ▶ Tub exterior is white
- ▶ No faucet holes
- ▶ Non-skid strips
- ▶ Feet are attached and leveled before shipment
- ▶ Tub is thoroughly inspected before shipment

### Foot Finishes:

- BP Polished Brass
- SN Brushed Nickel
- CP Polished Chrome
- WH White
- PN Polished Nickel
- ORB Oil-rubbed Bronze



Meets or exceeds the following specifications: A112-19-1M 1994.

**Custom Colors Available** (inside of tub is always white enamel):  
Painted bathtubs are considered "special order" and are not returnable  
\$160 Bisque or Black \$250 Designer Color

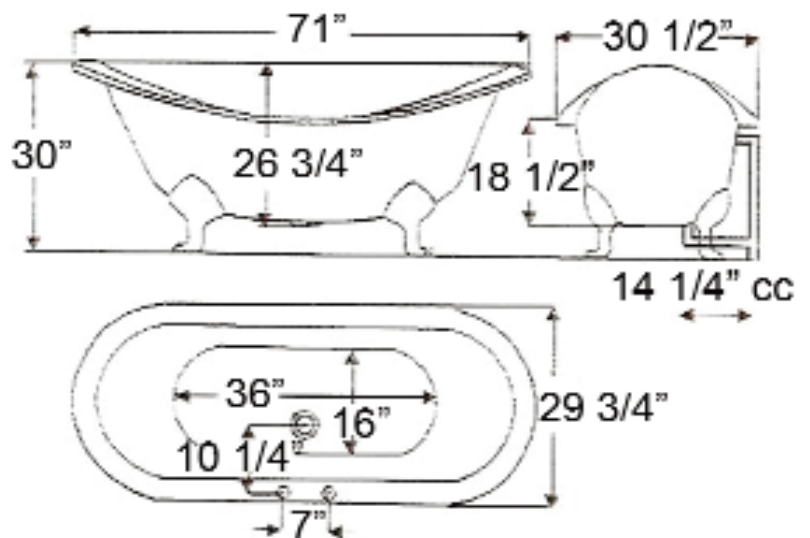

Dimensions of fixture are nominal and may vary within the range of tolerances established by ANSI Standard A112.19.2. Dimensions and specifications subject to change without notice.