

# DOUBLE ACRYLIC SLIPPER TUB

Cat. No.  
ADTS60



L: 60"  
W: 30"  
H: 22 1/2" (from floor) short end  
32" (from floor) tall end

Depth to Overflow: 13"

**The following is recommended for AT560 slipper tubs:**

- Faucets: part #4602, #4022, or #4025
- Use with Freestanding Bath Supplies: part #4502-PL
- Leg tub drain: part #5599

Gallon Capacity: 33  
Shipping Weight: 120 lbs.  
Empty Weight: 62 lbs.  
Filled Weight: 611 lbs.

## Features:

- ▶ Inside finish is either white or bisque to match outside color
- ▶ No faucet holes
- ▶ Aluminum ball and claw feet available in 8 finishes
- ▶ Smooth acrylic surface inside and out
- ▶ Tubs ship with feet attached and leveled
- ▶ Tubs are thoroughly inspected before shipment

### Foot Finishes:

**BQ** Bisque  
**BL** Black  
**BP** Polished Brass  
**CP** Polished Chrome  
**BN** Brushed Nickel  
**ORB** Oil Rubbed Bronze  
**PN** Polished Nickel  
**WH** White

### Tub Colors

**WH** White  
**BQ** Bisque



**Custom Colors Available** (inside of tub is always white enamel):  
Painted bathtubs are considered "special order" and are not returnable  
\$160 Bisque or Black \$250 Designer Color

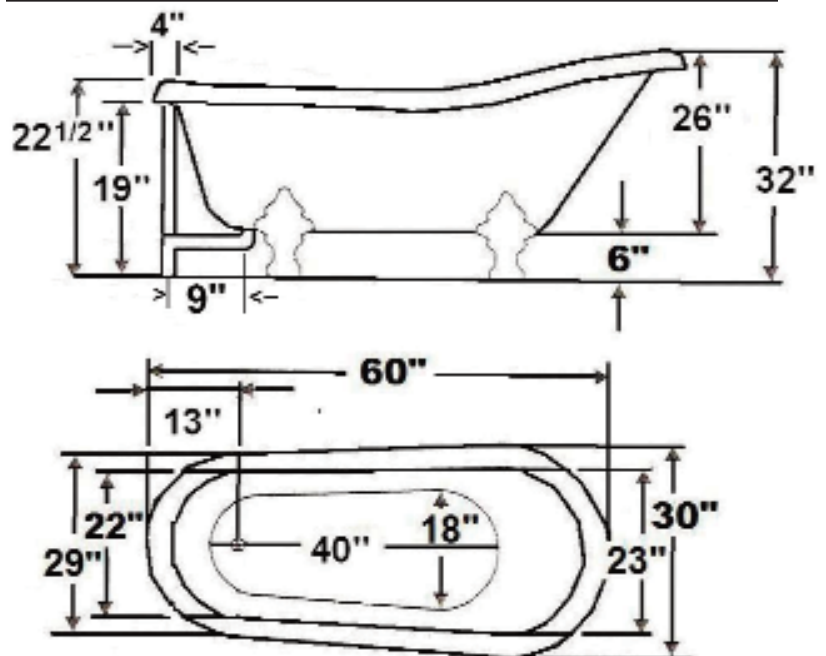

Dimensions are nominal and specifications subject to change without notice.