

Microwave Dimension Guide

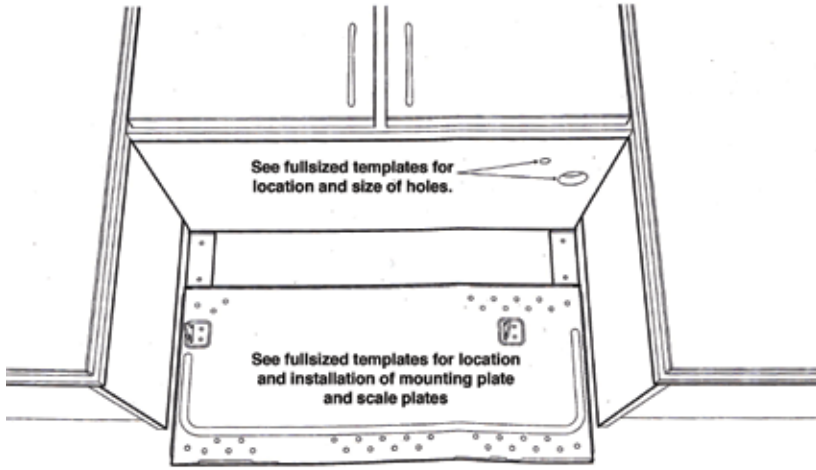

WALL TEMPLATE

1. Mark the location of the wall studs. Refer to INSTALLATION INSTRUCTIONS, 2 WALL CONSTRUCTION on page 6. Do not attempt to install this microwave oven if a wall stud cannot be located.
2. Use tape or pins to attach WALL TEMPLATE to the wall, being sure that the upper edge is exactly at the bottom of the top cabinet and centered.
 - Note:*
 - If the cabinets are not plumb, adjust the WALL TEMPLATE to the cabinets.
 - If the front edge of the cabinet is lower than the back edge, adjust the WALL TEMPLATE so that it is level with the cabinet front.
3. Clearly and accurately mark wall stud location on the WALL TEMPLATE. If stud location matches any location marked, drill a 3/32" hole into the stud for a wood screw. Drill a 5/8" hole at A, B, C, and D wherever there is NO stud.

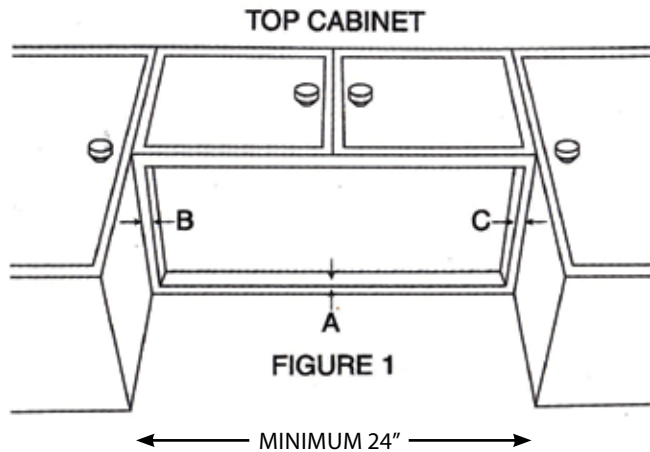

TOP CABINET TEMPLATE

1. If the top cabinet had a flat bottom, attach TOP CABINET TEMPLATE with pins or tape, aligning center line to the center line on the WALL TEMPLATE. If the top cabinet has a recessed bottom, cut the TOP CABINET TEMPLATE to fit with the recessed area according to the following procedure:
 - Measure the thickness of the cabinet edges labeled A, B and C. Cut the edge of the TOP CABINET TEMPLATE to allow for thickness. The guideline is marked in 1/4" increments for your convenience. See FIGURE 1.
 - Attach cut TOP CABINET TEMPLATE with pins or tape to the recessed area of the cabinet, carefully folding under the front edge if necessary so that the TEMPLATE is the exact size of the recessed area, and the center is aligned to the center line of the WALL TEMPLATE.
2. Drill 1/2" diameter holes at cutouts marked D and E.
3. Cut 1 1/2" diameter hole for Power Supply Cord marked F. If cabinets are metal, use Grommet 7 from INSTALLATION HARDWARE to surround opening.
4. Remove the WALL and TOP CABINET TEMPLATES.
5. For cabinets with a recessed bottom, fit wooden filler blocks (not included) at the areas marked H and I. The blocks must be at the same level as the bottom of the cabinet. See FIGURE 2.
6. Mark the cutout position on the filler blocks through the holes on the cabinet bottom and drill a 1/2" hole at the mark in each block. Place the filler blocks so that the hole in each block lines up with the 1/2" cutout in the bottom of the cabinet. The filler blocks may be temporarily held in place by tape.
7. Continue with the Installation Instructions in the Operation Manual on Page 9.

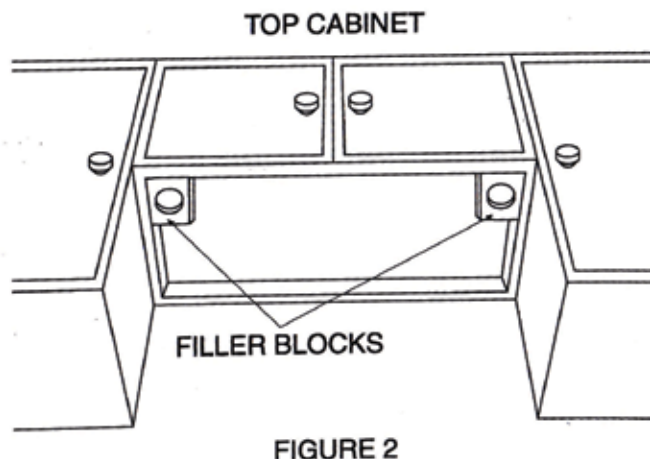

SHARP®