

STERLING®

A KOHLER COMPANY

ENSEMBLE™

Features

- Compression molded from our exclusive solid Vikrell® material
- Tongue-and-groove 4-piece modular design allows for easy "snap together" installation
- Integral apron with removable access panel
- Durable high-gloss finish
- Pump with air switch and grounding-type plug-in cord
- 6 Jets
- 10-year consumer/3-year commercial limited warranty
- Three-piece wall set with generous storage shelves
- 16" (40.6 cm) whirlpool bath depth (floor to top of threshold)
- 60-1/4" (153 cm) x 43-1/2" (110.5 cm) x 73-1/4" (186.1 cm) complete unit rough-in dimensions include flange
- 60" (152.4 cm) x 42" (106.7 cm) x 72" (182.9 cm) complete unit finished dimensions

42" (106.7 cm) WHIRLPOOL BATH AND WALL SURROUND

76110110
ALSO 76110120

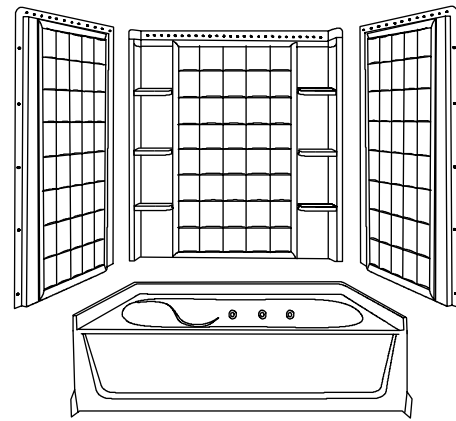

Codes/Standards Applicable

Specified model meets or exceeds the following:

- ASME A112.19.7M
- ANSI Z124.1.2
- NAHB Research Foundation, Inc.
- ASTM E162
- ASTM E662
- HUD, UM Bulletin 73A
- UL 1795

Colors/Finishes

- 0: White
- Other: Refer to Price Book for additional colors/finishes

Specified Model

Model	Complete Unit Description	Colors/Finishes	
76110110	42" (106.7 cm) whirlpool bath and wall surround, left drain	<input type="checkbox"/> 0	<input type="checkbox"/> Other _____
76110120	42" (106.7 cm) whirlpool bath and wall surround, right drain	<input type="checkbox"/> 0	<input type="checkbox"/> Other _____

Model	Wall Component Description	Colors/Finishes	
71112100	Back wall	<input type="checkbox"/> 0	<input type="checkbox"/> Other _____
71113110	Left end wall	<input type="checkbox"/> 0	<input type="checkbox"/> Other _____
71113120	Right end wall	<input type="checkbox"/> 0	<input type="checkbox"/> Other _____
71114100	Complete wall set	<input type="checkbox"/> 0	<input type="checkbox"/> Other _____
71115100	End wall set	<input type="checkbox"/> 0	<input type="checkbox"/> Other _____

ENSEMBLE™

Technical Information

Fixture*:	
Basin area:	
Bathing well	40" (101.6 cm) x 27" (68.6 cm)
Top area	52" (132.1 cm) x 35" (88.9 cm)
To overflow:	
Water depth	11" (27.9 cm)
Capacity	55 gal (208.2 L)
* Approximate measurements for comparison only.	

Pump:	V	Hz	A
1-speed	120	60	7

Model	Door maximum width	Door maximum height
76110110 76110120	58" (147.3 cm)	56" (142.2 cm)

Required Electrical Service

Dedicated circuit required, protected with Class A Ground-Fault Circuit-Interrupter (GFCI):	
Pump	120 V, 15 A, 60 Hz

Installation Notes

Install this product according to the installation guide.

Pump is supplied with a grounding type plug-in cord. Locate the outlet behind the whirlpool, and within 24" (61 cm) of the pump.

Do not disassemble the pump or piping as this could void the warranty.

Size the drain cutout to fit the drain assembly that will be used.

End stud positioning is critical if apron nailing-in flanges are to be used.

Studs should be positioned roughly as shown.

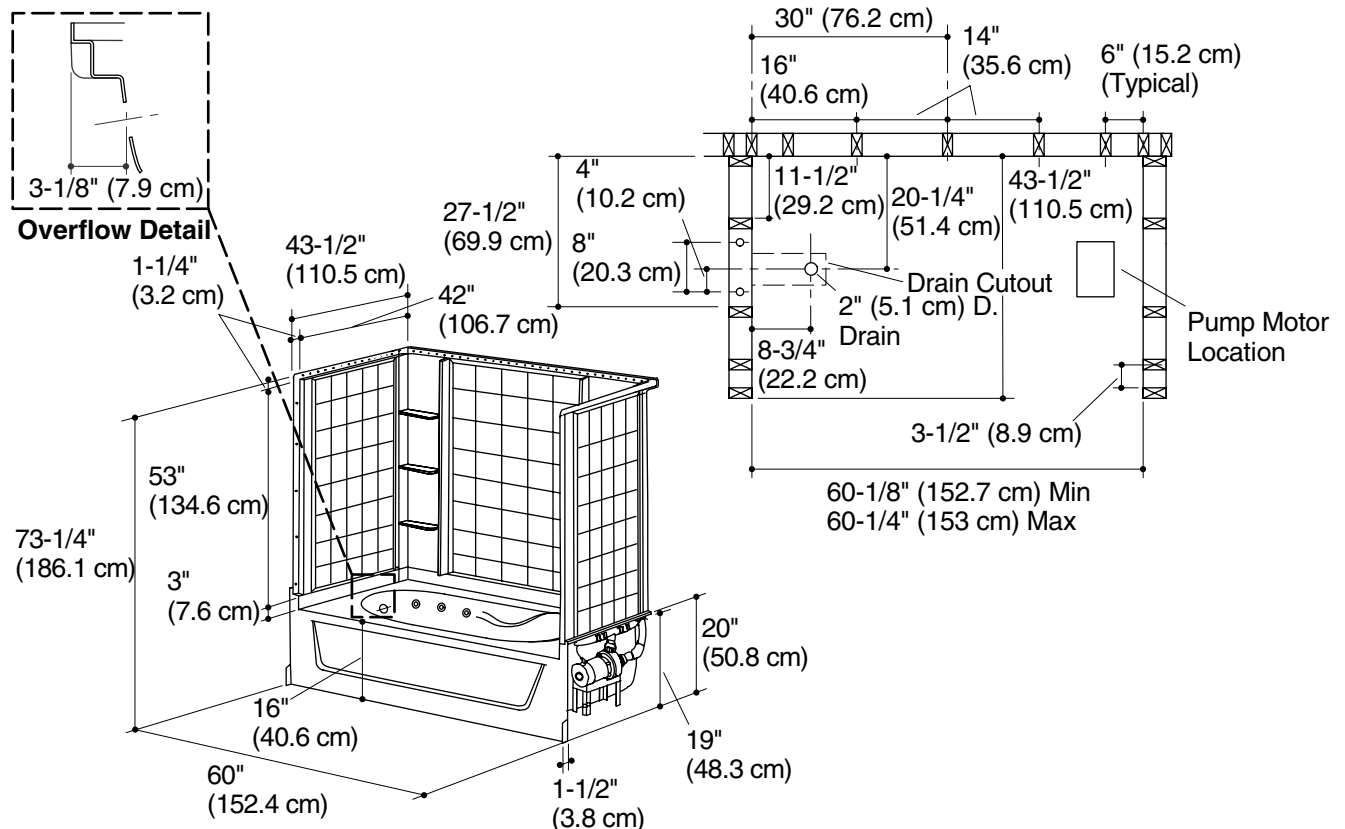

Product Diagram