



HEATING & AIR CONDITIONING

TECHNICAL GUIDE

96% TWO STAGE VARIABLE SPEED ECM GAS-FIRED RESIDENTIAL MULTI-POSITION GAS FURNACES

MODELS: TM9V

NATURAL GAS

40 - 120 MBH INPUT



Due to continuous product improvement, specifications are subject to change without notice.

Visit us on the web at www.york.com

Additional rating information can be found at www.ahridirectory.org

WARRANTY

Lifetime limited warranty on both heat exchangers to the original purchaser; a 20-year limited warranty from original installation date to subsequent purchaser.

10-year heat exchanger warranty on commercial applications.

Standard 5-year limited Parts warranty.

Extended 10-year limited parts warranty when product is registered online within 90 days of purchase for replacement or closing for new home construction.

DESCRIPTION

These compact units employ induced combustion, reliable hot surface ignition and high heat transfer aluminized tubular heat exchangers. The units are factory shipped for installation in upflow or horizontal applications and may be converted for downflow applications.

These furnaces are designed for residential installation in a basement, closet, alcove, attic, recreation room or garage and are also ideal for commercial applications. All units are factory assembled, wired and tested to assure safe dependable and economical installation and operation.

These units are Category IV listed and may be vented either through side wall or roof applications using approved plastic combustion air and vent piping.

FEATURES

- Two stage heating operation includes two stage gas valve, two stage inducer operation and variable speed ECM blower operation. Adjustable delay timer allows two stage operation with a single stage thermostat.
- Easily applied in upflow, horizontal left or right, or downflow installation with minimal conversion necessary.
- Compact, easy to install, ideal height 33" tall cabinet.
- ECM variable speed drive for cooling SEER enhancement, improved comfort with optional airflow delay profiles, and continuous fan options for IAQ performance.
- Easy access to controls to connect power/control wiring.
- Built-in, high level self diagnostics with fault code display.
- Low unit amp requirement for easy replacement application.
- All models are convertible to use propane (LP) gas.
- Electronic Hot Surface Ignition saves fuel cost with increased dependability and reliability.
- 100% shut off main gas valve for extra safety.
- 24V, 40 VA control transformer and blower relay supplied for add-on cooling.
- Hi-tech tubular aluminized steel primary heat exchanger with stainless steel tube/aluminum fin secondary heat exchanger for outstanding efficiency.
- Solid removable bottom panel allows easy conversion.
- Airflow leakage less than 1% of nominal airflow for duct-blaster conditions.
- No knockouts to deal with, making installation easier.
- Movable duct connector flanges for application flexibility.
- Quiet inducer operation, burner, and blower operation.
- Inducer rotates for easy conversion of venting options.
- Fully supported blower assembly for easy access and removal of blower.
- External air filters used for maximum flexibility in meeting customers IAQ needs.
- Insulated blower compartment for thermal and acoustic performance.
- 1/4 turn knobs provided for easy independent door removal.
- Internal condensate trap design (patent pending) provides condensate management options and is self priming to prevent nuisance problems.
- Protection included from air intake, exhaust vent or condensate blockage.
- Venting applications maybe installed as either 2 pipe sealed combustion or single pipe vent using indoor combustion air.

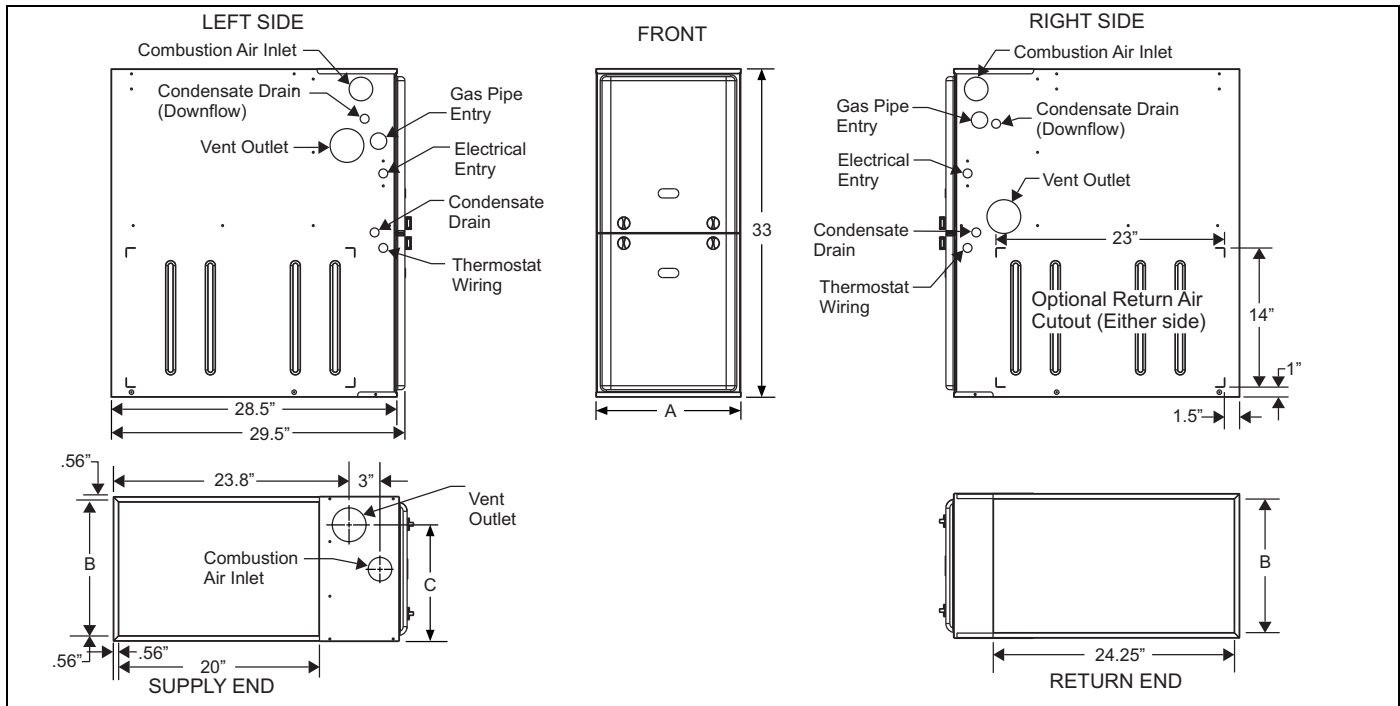

Cabinet & Duct Dimensions

Model	Nominal CFM (m ³ /min)	Cabinet Size	Cabinet Dimensions (Inches)			Approximate Operating Weights
			A	B	C	Lbs
TM9V040A10MP11	1000	A	14-1/2	13-3/8	11-3/4	113
TM9V060B12MP11	1200	B	17-1/2	16-3/8	13-1/4	122
TM9V080B12MP11	1200	B	17-1/2	16-3/8	13-1/4	126
TM9V080C16MP11	1600	C	21	19-7/8	16-1/2	136
TM9V100C16MP11	1600	C	21	19-7/8	18-1/4	142
TM9V100C20MP11	2000	C	21	19-7/8	18-1/4	145
TM9V120D20MP11	2000	D	24-1/2	23-3/8	21-3/4	156

Ratings & Physical / Electrical Data

Model	Input High/Low	Output High/Low	Total Unit	AFUE	High Fire Air Temp. Rise	Low Fire Air Temp. Rise
	MBH	MBH	Amps	%	°F	°F
TM9V040A10MP11	40/26	38/25	9	96	30 - 60	20 - 50
TM9V060B12MP11	60/39	58/37	9	96	35 - 65	35 - 65
TM9V080B12MP11	80/52	77/50	9	96	40 - 70	35 - 65
TM9V080C16MP11	80/52	77/50	12	96	35 - 65	35 - 65
TM9V100C16MP11	100/65	96/62	12	96	35 - 65	30 - 65
TM9V100C20MP11	100/65	96/62	14	96	35 - 65	35 - 65
TM9V120D20MP11	120/78	115/75	14	96	35 - 65	35 - 65
Model	Max. Outlet Air Temp.	Blower		Blower Size	Max. Over-current Protect	Min. Wire Size (awg) @ 75 ft. One Way
	°F	HP	Amps	In.		
TM9V040A10MP11	180	1/2	7	11 X 8	15	14
TM9V060B12MP11	180	1/2	7	11 x 8	15	14
TM9V080B12MP11	175	1/2	7	11 x 8	15	14
TM9V080C16MP11	165	3/4	10.2	11 x 10	15	14
TM9V100C16MP11	180	3/4	10.2	11 x 10	15	14
TM9V100C20MP11	170	1	12.7	11 x 11	20	12
TM9V120D20MP11	180	1	12.7	11 x 11	20	12

Annual Fuel Utilization Efficiency (AFUE) numbers are determined in accordance with DOE Test procedures. Wire size and over current protection must comply with the National Electrical Code (NFPA-70-latest edition) and all local codes. The furnace shall be installed so that the electrical components are protected from water.

FILTER PERFORMANCE

The airflow capacity data published in the "Blower Performance" table shown represents blower performance WITHOUT filters.

All applications of these furnaces require the use of field installed air filters. All filter media and mounting hardware or provisions must be field installed external to the furnace cabinet. DO NOT attempt to install any filters inside the furnace.

NOTICE

Single side return above 1800 CFM is approved as long as the filter velocity does not exceed filter manufacturer's recommendation and a transition is used to allow use on a 20x25 filter.

Recommended Filter Sizes (High velocity 600 FPM)

CFM	Cabinet Size	Side (in)	Bottom (in)
1000	A	16 x 25	14 x 25
1200	B	16 x 25	16 x 25
1600	C	16 x 25	20 x 25
2000	C	(2) 16 x 25	20 x 25
2000	D	(2) 16 x 25	22 x 25

- Air velocity through throwaway type filters may not exceed 300 feet per minute (91.4 m/min). All velocities over this require the use of high velocity filters.
- Do not exceed 1800 CFM using a single side return and a 16x25 filter. For CFM greater than 1800, you may use two side returns or one side and the bottom or one return with a transition to allow use of a 20x25 filter.

Unit Clearances to Combustibles

Application	Upflow	Downflow	Horizontal
Top	1"	0"	0"
Vent	0"	0"	0"
Rear	0"	0"	0"
Side	0"	0"	1"
Front*	0"	0"	0"
Floor	Combustible	Combustible ¹	Combustible
Closet	Yes	Yes	Yes
Line Contact	No	No	Yes

- For combustible floors only when used with special sub-base.
* - 24" clearance in front and 18" on side recommended for service access.
All furnaces approved for alcove and attic installation.

ACCESSORIES

Propane (LP) Conversion Kit - This accessory conversion kit may be used to convert natural gas (N) units for propane (LP) operation.

S1-1NP0347 - All Models

Concentric Vent Termination - For use through rooftop, sidewall. Allows combustion air to enter and exhaust to exit through single common hole. Eliminates unsightly elbows for a cleaner installation.

S1-1CT0302 (2") & S1-1CT0302-636 (2")

S1-1CT0303 (3") & S1-1CT0303-636 (3")

Sidewall Vent Termination Kit - For use on sidewall, two-pipe installations only. Provide a more attractive termination for locations where the terminal is visible on the side of the home.

S1-1HT0901 (3")

S1-1HT0902 (2")

Condensate Neutralizer Kit - Neutralizer cartridge has a 1/2" plastic tube fittings for installation in the drain line. Calcium carbonate refill media is also available from the Source 1 Parts (P/N 026-30228-000).

1NK0301

Side Return Filter Racks -

S1-1SR0200 - All Models

S1-1SR0402 - All Models

Bottom Return Filter Racks - 1BR05xx series are galvanized steel filter racks. 1BR06xx are pre-painted steel filter racks to match the appearance of the furnace cabinet.

S1-1BR0514 or 1BR0614 - For 14-1/2" cabinets

S1-1BR0517 or 1BR0617 - For 17-1/2" cabinets

S1-1BR0521 or 1BR0621 - For 21" cabinets

S1-1BR0524 or 1BR0624 - For 24-1/2" cabinets

Combustible Floor Base Kit - For installation of these furnaces in downflow applications directly onto combustible flooring material, These kits are required to prevent potential overheating situations. Combustible floor base kit provides access for combustible airflow.

S1-1CB0514 - For 14-1/2" cabinets

S1-1CB0517 - For 17-1/2" cabinets

S1-1CB0521 - For 21" cabinets

S1-1CB0524 - For 24-1/2" cabinets

High Altitude Pressure Switches - For installation where the altitude is less than 5,000 feet it is not required that the pressure switch be changed. For altitudes above 5,000 feet, see kits below.

S1-1PS3308 - All Models

Thermostats - Compatible thermostat controls are available through accessory sourcing. For optimum performance and installation, refer to the UPGNET "Low Voltage Wiring Diagram" document to select and apply controls.

Table 1: Air Flow Data

HIGH / LOW SPEED COOLING AND HEAT PUMP CFM								
040A10		060B12		080B12		Jumper Settings		
High	Low	High	Low	High	Low	COOL Tap	ADJ Tap*	
1080	750	1343	865	1320	882	A	B	
960	680	1116	727	1093	755	B	B	
980	690	1235	791	1203	810	A	A	
870	620	1026	661	1001	693	B	A	
890	620	1079	709	1080	730	A	C	
770	550	889	590	880	641	C	B	
790	560	900	599	910	642	B	C	
650	480	787	531	803	585	D	B	
700	500	814	542	836	597	C	A	
590	440	712	490	738	557	D	A	
640	450	725	499	749	561	C	C	
540	400	641	456	682	529	D	C	
080C16		100C16		100C20		Jumper Settings		
High	Low	High	Low	High	Low	COOL Tap	ADJ Tap*	
1787	1171	1818	1192	2019	1290	A	B	
1503	987	1545	1030	1790	1174	B	B	
1620	1053	1661	1083	1818	1195	A	A	
1405	914	1427	936	1630	1068	B	A	
1462	964	1497	991	1649	1082	A	C	
1217	785	1234	819	1269	848	C	B	
1245	818	1265	832	1432	956	B	C	
940	608	977	648	1078	704	D	B	
1091	702	1116	728	1169	770	C	A	
852	551	884	572	986	638	D	A	
983	626	1019	666	1062	685	C	C	
764	544	791	519	866	576	D	C	
				120D20		Jumper Settings		
				High	Low	COOL Tap	ADJ Tap*	
				2006	1397	A	B	
				1687	1131	B	B	
				1845	1282	A	A	
				1552	1050	B	A	
				1694	1157	A	C	
				1502	1011	C	B	
				1400	944	B	C	
				1365	922	D	B	
				1364	931	C	A	
				1232	808	D	A	
				1225	808	C	C	
				1117	718	D	C	
HIGH / LOW HEAT CFM								
040A10		060B12		80B12		Jumper Settings		
High	Low	High	Low	High	Low	HEAT Tap	ADJ Tap*	
960	670	1364	843	1433	945	A	Any	
840	590	1253	745	1320	887	B	Any	
740	520	1102	660	1223	840	C	Any	
640	450	1014	607	1134	768	D	Any	
80C16		100C16		100C20		Jumper Settings		
High	Low	High	Low	High	Low	HEAT Tap	ADJ Tap*	
1684	1095	1803	1182	2194	1417	A	Any	
1542	1011	1686	1084	1999	1290	B	Any	
1426	927	1530	1016	1799	1182	C	Any	
1289	832	1427	936	1614	1062	D	Any	
				120D20		Jumper Settings		
				High	Low	HEAT Tap	ADJ Tap*	
				1937	1323	A	Any	
				1757	1199	B	Any	
				1594	1062	C	Any	
				1429	957	D	Any	

All CFM's are shown at 0.5" w.c. external static pressure. These units have variable speed motors that automatically adjust to provide constant CFM from 0.0" to 0.6" w.c. static pressure. From 0.6" to 1.0" static pressure, CFM is reduced by 2% per 0.1" increase in static. Operation on duct systems with greater than 1.0" w.c. external static pressure is not recommended.

NOTE: At some settings, LOW COOL and/or LOW HEAT airflow may be lower than what is required to operate an airflow switch on certain models of electronic air cleaners. Consult the instructions for the electronic air cleaner for further details.

* The ADJ "D" tap should not be used.