

SPECIFICATION SHEET

PRODUCT FAMILY: Sinks FINISH: Fireclay Matte Black SERIES: CISTERNA MODEL: CCK110-15

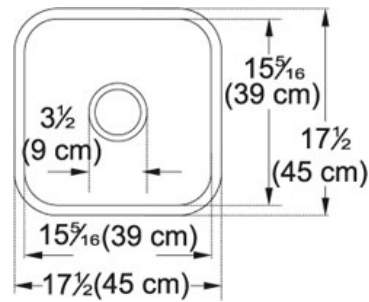

Product Information

FUN#	126.0066.140
US Part Number	CCK110-15MB
Minimum Cabinet Size	21"
Drain Opening	3 1/2"
Outer Dimensions	17 1/2"x17 1/2"x8 5/8"
Bowl Size	15 5/16"x15 5/16"x7 7/8"
Number of Bowls	1
Cut-Out Size	445 mmx445 mm
*	Dimensions may vary by 2% (plus or minus) due to material attributes and firing process **Installation of this fireclay product requires custom cabinetry. Franke recommends that an experienced cabinet maker build the new cabinet, or is responsible for modifications to existing cabinets for this product.
Type of Material	Fireclay

Accessories



112.0048.589

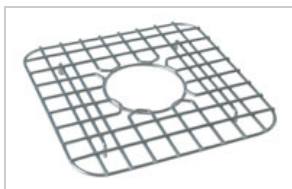

112.0066.222

Suggested Products



115.0196.963