

# SPECIFICATION SHEET

PRODUCT FAMILY: Sinks FINISH: Fireclay White SERIES: CISTERNA MODEL: CCK110-19

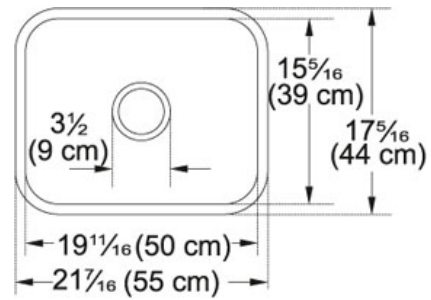

## Product Information

<b>FUN#</b>	126.0066.147
<b>US Part Number</b>	CCK110-19WH
<b>Minimum Cabinet Size</b>	27"
<b>Drain Opening</b>	3 1/2"
<b>Outer Dimensions</b>	21 5/8"x17 3/16"
<b>Bowl Size</b>	19 11/16"x15 3/8"x7 7/8"
<b>Number of Bowls</b>	1
*	Dimensions may vary by 2% (plus or minus) due to material attributes and firing process **Installation of this fireclay product requires custom cabinetry. Franke recommends that an experienced cabinet maker build the new cabinet, or is responsible for modifications to existing cabinets for this product.
<b>Type of Material</b>	Fireclay

**Accessories**

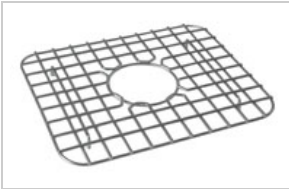

112.0066.223