

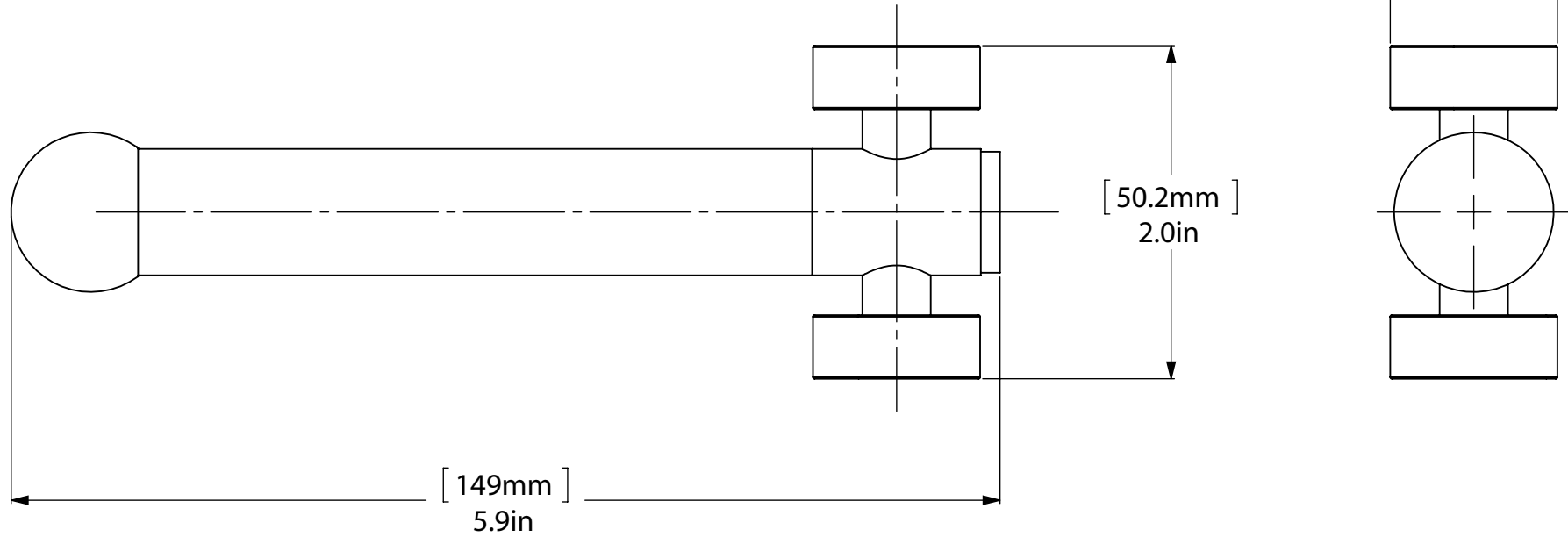

ITEM NO.	PART NUMBER	DESCRIPTION	QTY.
1	TU34-4	BOTTOM TUBE	1
2	BL1T-34	End Ball	1
3	CH-2	CONNECTOR 1	1
4	PIN-1	PIN	1
5	Card-1	END LOCK	2

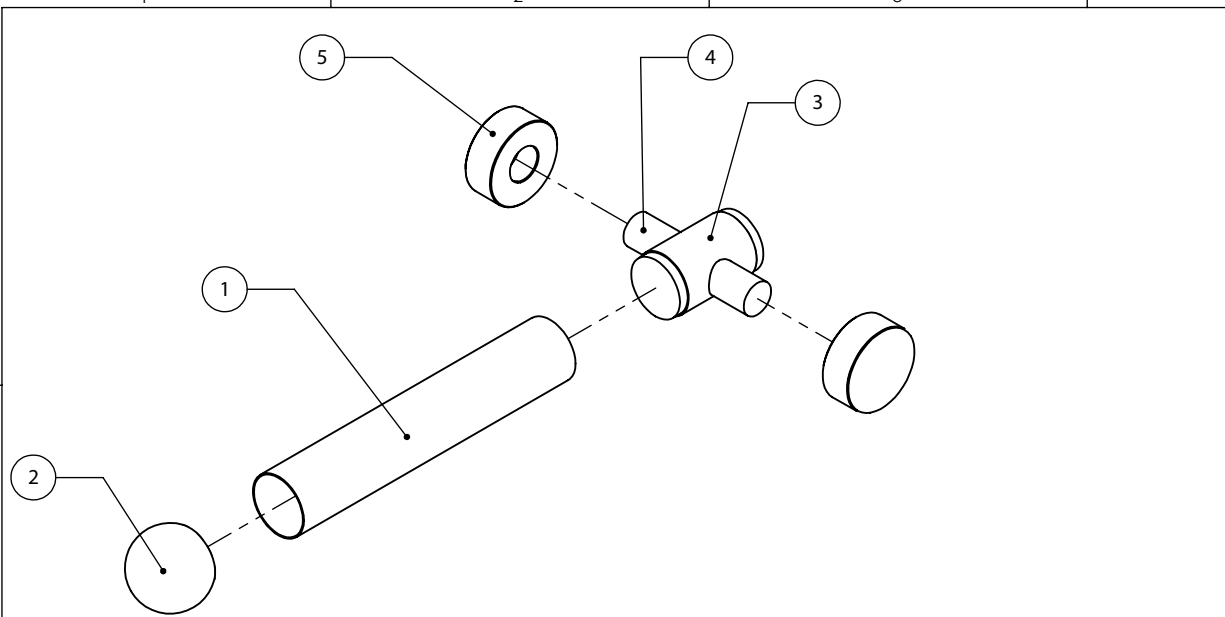

CONFIDENTIALITY/LIMITED LIABILITY STATEMENT
 This document (and any files attached to it) is confidential and intended only for the person or entity to which it is delivered. If you are not the intended recipient, then you have received this document by mistake and any use, dissemination, forwarding, printing or copying of this document and its file attachments is prohibited. Please notify ALLIED BRASS INC. immediately either by telephone or by email, delete the misdirected document from your system and destroy any copies you have made of it. We do not accept any liability for any loss or damage which may arise from your receipt of this document.

UNLESS OTHERWISE STATED			INITIALS	DATE	ITEM	QTY	DRG/PART NO	CLIENT:			
DO NOT SCALE	X.XXX	+/-0.025	DESIGNED	IJM	MATERIAL		BRASS	WEIGHT		FINISH	TBD
DRAWING	X.XX	+/-0.1	DRAWN	IJM	HEAT TREAT		NA	QUANTITY			
CHAMFER ALL	X	+/-0.75	CHECKED	R. ANDRIS	CUSTOMER		CUSTOMER No		---		
EDGES 0.5X4°	ANGLES		PROJ.ENG		DESCRIPTION: BOTTOM ASSY			DRAWING No. CH-90-AS001		REV	
DRAWING ISO	X.XX	+/-0.05*	SAFETY							0	
	X	+/-0.1*	APPROVED	R. ANDRIS				SCALE 1:1 SHEET: 01 A4			
	X	+/-0.5*	FILENAME	CH-90-AS001							
		3.2	MACHINED FINISH								

ITEM NO.	PART NUMBER	DESCRIPTION	QTY.
1	CNT-1	CONNECTOR 2	1
T	RD-1	THREADED ROD	1

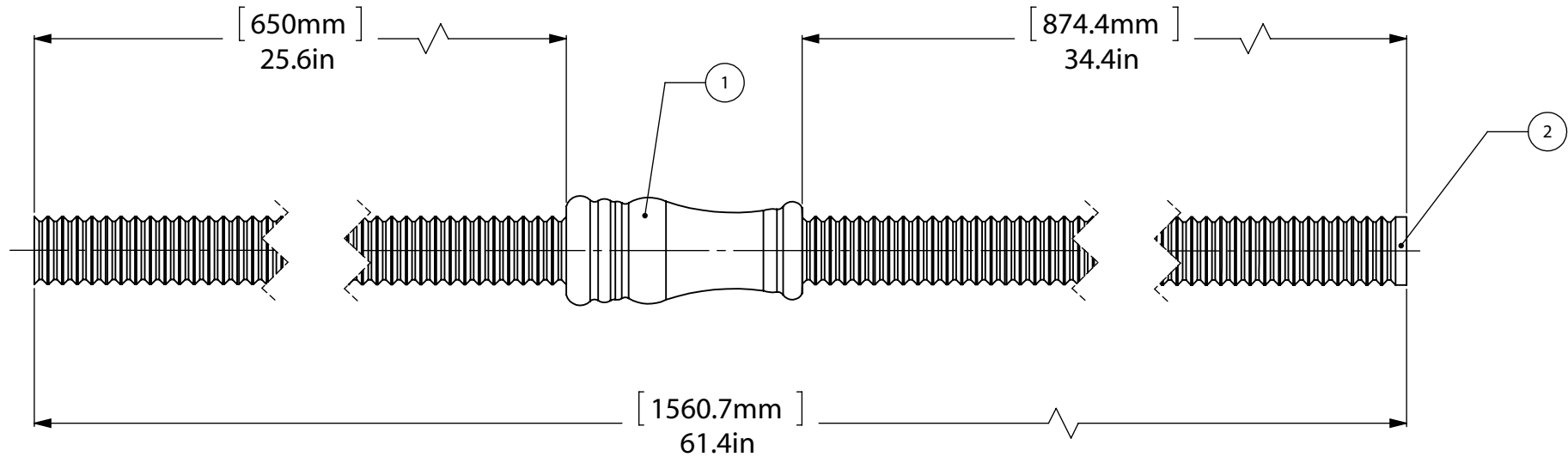

CONFIDENTIALITY/LIMITED LIABILITY STATEMENT
 This document (and any files attached to it) is confidential and intended only for the person or entity to which it is delivered. If you are not the intended recipient, then you have received this document by mistake and any use, dissemination, forwarding, printing or copying of this document and its file attachments is prohibited. Please notify ALLIED BRASS INC. immediately either by telephone or by email, delete the misdirected document from your system and destroy any copies you have made of it. We do not accept any liability for any loss or damage which may arise from your receipt of this document.

UNLESS OTHERWISE STATED			INITIALS	DATE	ITEM	QTY	DRG/PART NO	CLIENT:				
DO NOT SCALE	X.XXX	+/-0.025	DESIGNED	IJM	MATERIAL		BRASS	WEIGHT		FINISH	TBD	
DRAWING	X.XX	+/-0.1	DRAWN	IJM	HEAT TREAT		NA			QUANTITY		
CHAMFER ALL	X	+/-0.75	CHECKED	R. ANDRIS	CUSTOMER			CUSTOMER No		---		
EDGES 0.5X4*	ANGLES		PROJ.ENG		DESCRIPTION:					DRAWING No.		
DRAWING ISO	X.XX	+/-0.05*	SAFETY		CONNECTOR					CH-90-AS002		REV
	X.X	+/-0.1*	APPROVED	R. ANDRIS						SCALE		1:1
	X	+/-0.5*	FILENAME	CH-90-AS002								
		3.2										

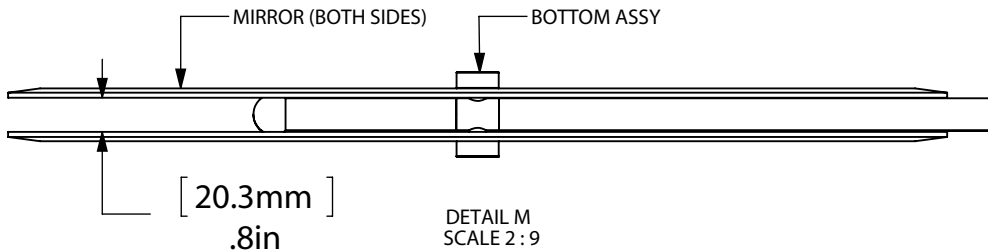

ITEM NO.	PART NUMBER	DESCRIPTION	QTY.
1	CH90-AS001	BOTTOM ASSY	2
2	CNT-1	CONNECTOR 2	2
3	TU34-30	LONG TUBE	4
4	CRRD-34	RING	6
5	FRBP	BASE PLATE	2
6	CH-1	BASE TUBE	2
7	MRRD-90	MIRROR	2

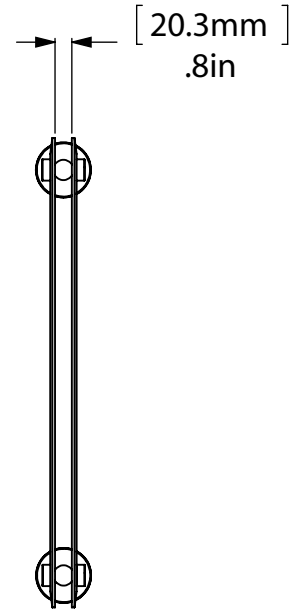
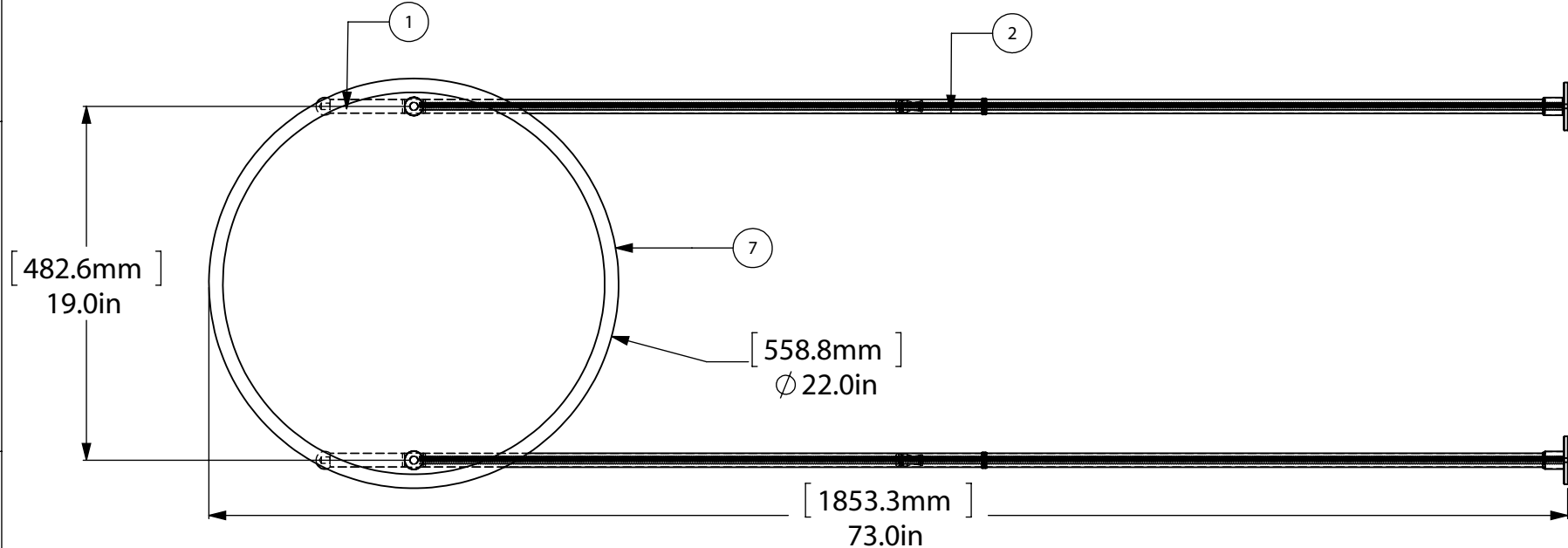
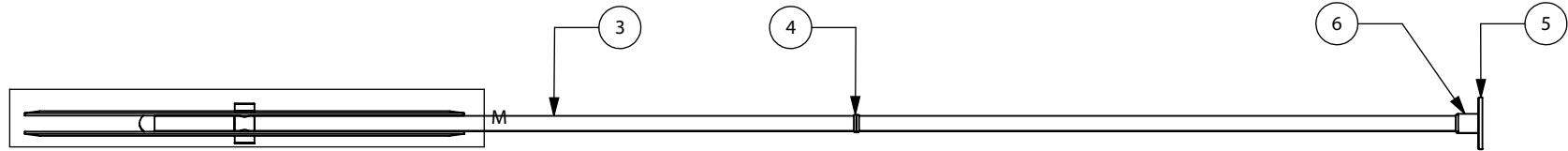

CONFIDENTIALITY/LIMITED LIABILITY STATEMENT
 This document (and any files attached to it) is confidential and intended only for the person or entity to which it is delivered. If you are not the intended recipient, then you have received this document by mistake and any use, dissemination, forwarding, printing or copying of this document and its file attachments is prohibited. Please notify ALLIED BRASS INC. immediately either by telephone or by email, delete the misdirected document from your system and destroy any copies you have made of it. We do not accept any liability for any loss or damage which may arise from your receipt of this document.

UNLESS OTHERWISE STATED			INITIALS	DATE	ITEM	QTY	DRG/PART NO	CLIENT:			
DO NOT SCALE	X.XXX	+/-0.025	DESIGNED	IJM	MATERIAL		BRASS	WEIGHT		FINISH	TBD
DRAWING	X.XX	+/-0.1	DRAWN	IJM	HEAT TREAT		NA			QUANTITY	
CHAMFER ALL	X	+/-0.25	CHECKED	R. ANDRIS	CUSTOMER					CUSTOMER No	---
EDGES 0.5X4°		+/-0.75	PROJ.ENG		DESCRIPTION:			DRAWING No.			
DRAWING ISO	ANGLES		SAFETY		CH-90 ASSY						
	X.XX	+/-0.05*	APPROVED	R. ANDRIS							DRAWING No.
	X.X	+/-0.1*	FILENAME	CH-90-AS005				SCALE	1:9	SHEET: 01	A4
	X	+/-0.5*									
	MACHINED FINISH	3.2									

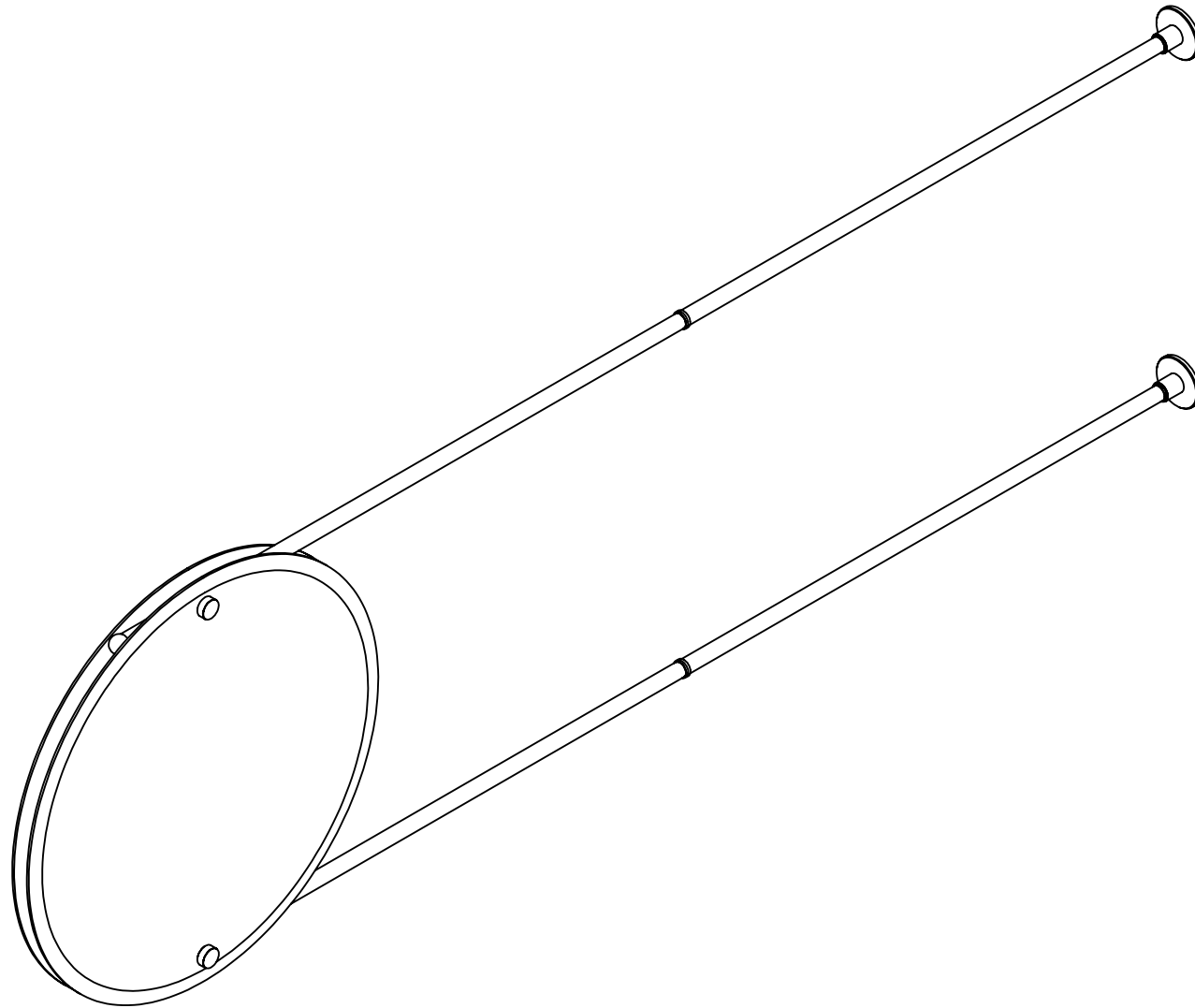

CONFIDENTIALITY/LIMITED LIABILITY STATEMENT
 This document (and any files attached to it) is confidential and intended only for the person or entity to which it is delivered. If you are not the intended recipient, then you have received this document by mistake and any use, dissemination, forwarding, printing or copying of this document and its file attachments is prohibited. Please notify ALLIED BRASS INC. immediately either by telephone or by email, delete the misdirected document from your system and destroy any copies you have made of it. We do not accept any liability for any loss or damage which may arise from your receipt of this document.

UNLESS OTHERWISE STATED			INITIALS	DATE	ITEM	QTY	DRG/PART NO	CLIENT:				
DO NOT SCALE	X.XXX	+/-0.025	DESIGNED	IJM	MATERIAL		BRASS	WEIGHT		FINISH	TBD	
DRAWING	X.XX	+/-0.1	DRAWN	IJM	HEAT TREAT		NA	QUANTITY				
CHAMFER ALL	X.X	+/-0.25	CHECKED	R. ANDRIS	CUSTOMER			CUSTOMER No	---			
EDGES 0.5X4°	X	+/-0.75	PROJ.ENG		DESCRIPTION:				DRAWING No.	REV		
DRAWING ISO	ANGLES		SAFETY		CH-90 ASSY					CH-90-AS005	0	
	X.XX	+/-0.05*	APPROVED	R. ANDRIS								
	X.X	+/-0.1*	FILENAME	CH-90-AS005					SCALE	1:8	SHEET: 01	A4
	X	+/-0.5*										
		+/-0.5*										
		3.2										
FIRST ANGLE PROJECTION	MACHINED FINISH											

ITEM NO.	PART NUMBER	DESCRIPTION	QTY.
1	CH90-AS003	SINGLE ASSY	2
2	MRRD-90	MIRROR	2

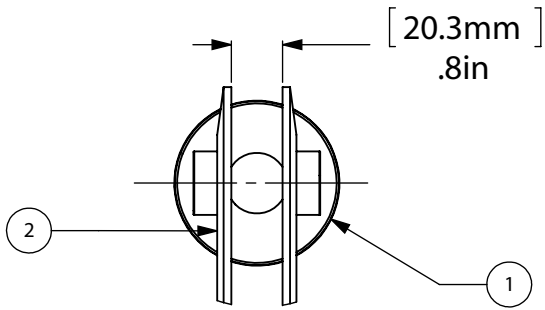

DETAIL L
SCALE 1:3

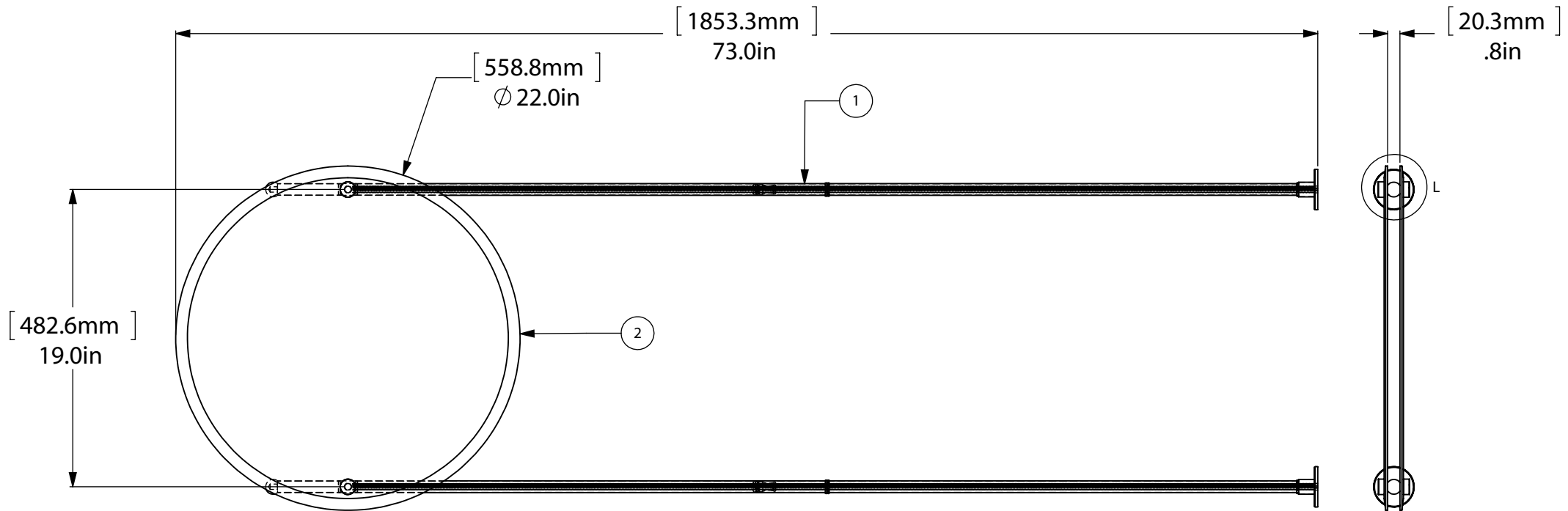

CONFIDENTIALITY/LIMITED LIABILITY STATEMENT
 This document (and any files attached to it) is confidential and intended only for the person or entity to which it is delivered. If you are not the intended recipient, then you have received this document by mistake and any use, dissemination, forwarding, printing or copying of this document and its file attachments is prohibited. Please notify ALLIED BRASS INC. immediately either by telephone or by email, delete the misdirected document from your system and destroy any copies you have made of it. We do not accept any liability for any loss or damage which may arise from your receipt of this document.

UNLESS OTHERWISE STATED			INITIALS	DATE	ITEM	QTY	DRG/PART NO	CLIENT:			
DO NOT SCALE	X.XXX	+/-0.025	DESIGNED	IJM	MATERIAL		BRASS	WEIGHT		FINISH	TBD
DRAWING	X.XX	+/-0.1	DRAWN	IJM	HEAT TREAT		NA	QUANTITY			
CHAMFER ALL	X	+/-0.25	CHECKED	R. ANDRIS	CUSTOMER			CUSTOMER No	---		
EDGES 0.5X4*			PROJ.ENG		DESCRIPTION:			DRAWING No.		REV	
DRAWING ISO			SAFETY		BOTTOM ASSY					0	
			APPROVED	R. ANDRIS							
			FILENAME	CH-90-AS001	SCALE		1:9	SHEET: 01	A4		

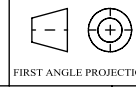

ANGLES
 X.XX +/-0.05*
 X.X +/-0.1*
 X +/-0.5*
 MACHINED FINISH 3.2