

# SPEAKMAN THE EDGE™

## Roman Tub Faucet SB-1531

SPECIFICATION

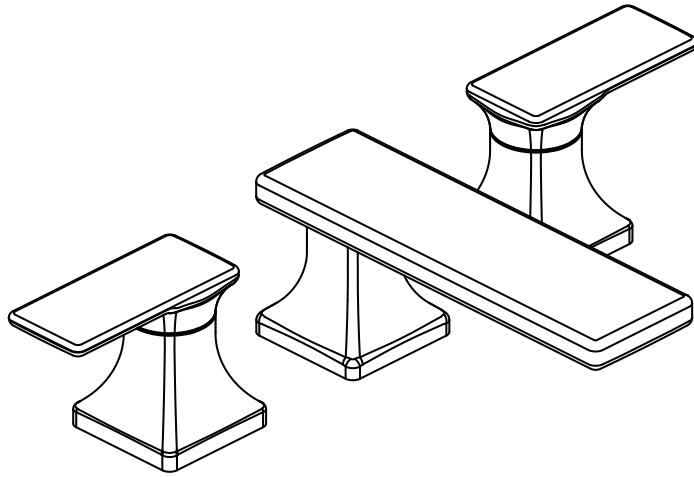

### FEATURES:

- Lead-free brass construction
- ¼ turn ceramic cartridges
- Lever handles
- Modern square styling
- 3-hole installation

### COMPLIANCE:

- Certified to ASME A112.18.1/CSA B125.1 and NSF 61 standards

### AVAILABLE FINISHES:

ADD SUFFIX TO MODEL #

- Polished Chrome (standard)
- Brushed Nickel  -BN

### WARRANTY:

- 1 year limited

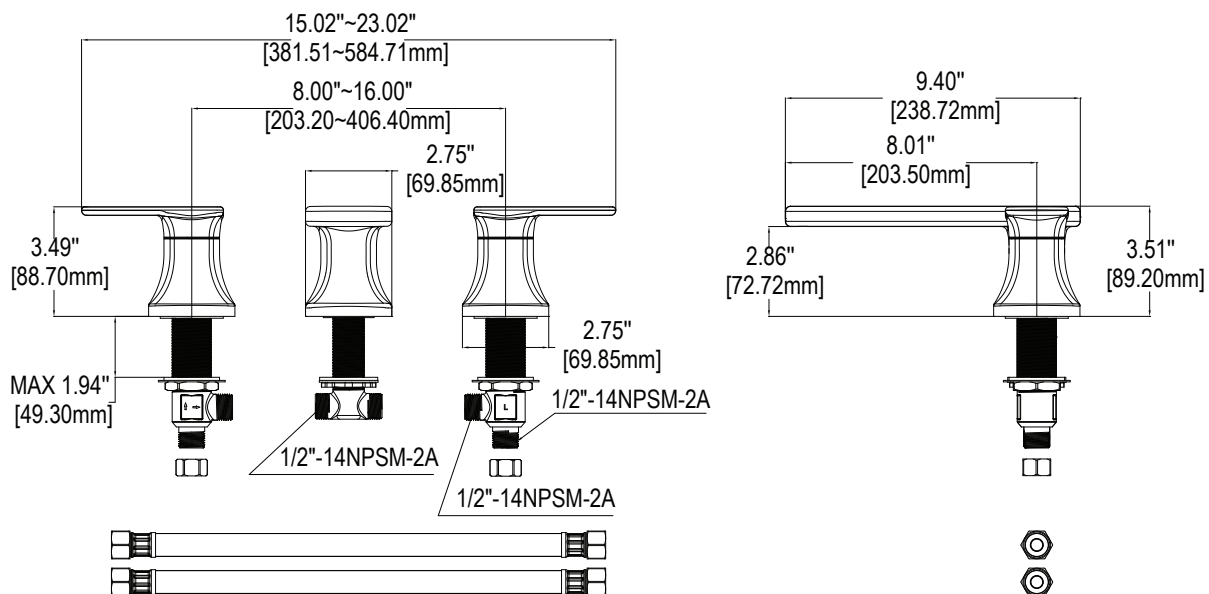

THIS SPACE FOR ARCHITECT/ENGINEER APPROVAL.

# SPEAKMAN®

400 ANCHOR MILL ROAD | NEW CASTLE, DE 19720  
P: 800-537-2107 | F: 800-977-2747  
WWW.SPEAKMANCOMPANY.COM

Management Systems  
Registered to ISO 9001

REVISION DATE: MAY 2013