

SPEAKMAN TIBER™

Pressure Balance Valve & Trim SM-11000-P

SPECIFICATION

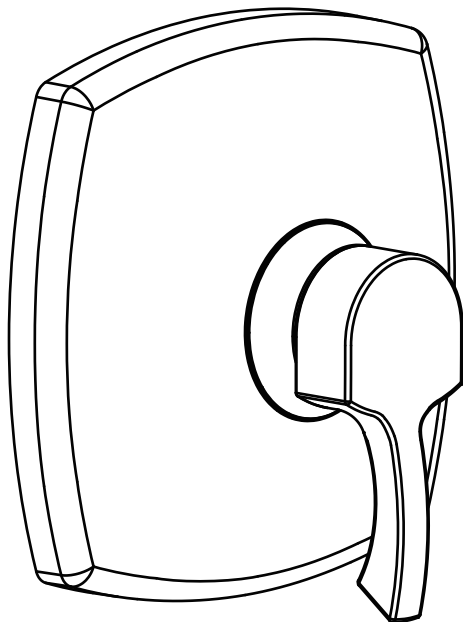

FEATURES:

- Shower valve & trim kit
- Modern square styling
- Anti-scald pressure balance valve
- Built-in check valves
- Pressure balancing & ceramic temperature regulating cartridge
- Adjustable temperature limit stop
- Integral stops

COMPLIANCE:

- Certified to ASME A112.18.1/
CSA B125.1 and ASSE 1016
standards



AVAILABLE FINISHES:

ADD SUFFIX TO MODEL #

- Polished Chrome (standard)
- Brushed Nickel -BN

WARRANTY:

- 1 year limited

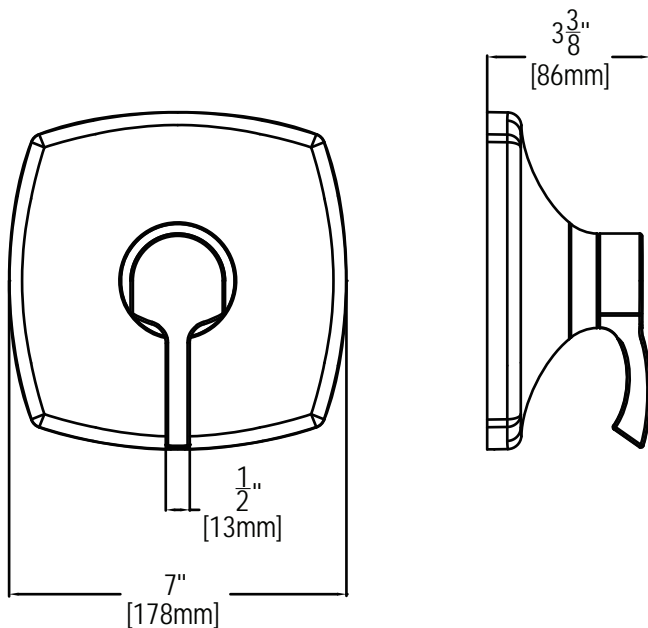

THIS SPACE FOR ARCHITECT/ENGINEER APPROVAL.

SPEAKMAN®

400 ANCHOR MILL ROAD | NEW CASTLE, DE 19720
P: 800-537-2107 | F: 800-977-2747
WWW.SPEAKMANCOMPANY.COM

Management Systems
Registered to ISO 9001

REVISION DATE: MAY 2013