

# SPECIFICATION SHEET

PRODUCT FAMILY: Sinks FINISH: Fireclay Matte White SERIES: CISTERNA MODEL: CCK110-13

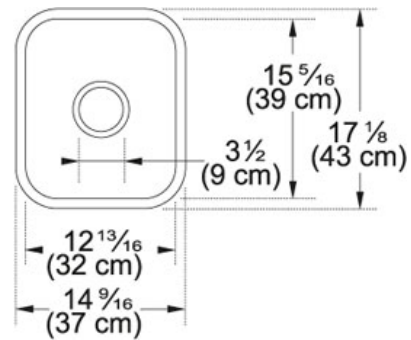

## Product Information

<b>FUN#</b>	126.0256.640
<b>US Part Number</b>	CCK110-13MW
<b>Minimum Cabinet Size</b>	18"
<b>Drain Opening</b>	3 1/2"
<b>Outer Dimensions</b>	14 9/16"x17 1/8"x8 5/8"
<b>Bowl Size</b>	12 3/8"x15 5/16"x7 7/8"
<b>Number of Bowls</b>	1
<b>Cut-Out Size</b>	435 mmx370 mm
<b>*</b>	Dimensions may vary by 2% (plus or minus) due to material attributes and firing process **Installation of this fireclay product requires custom cabinetry. Franke recommends that an experienced cabinet maker build the new cabinet, or is responsible for modifications to existing cabinets for this product.
<b>Type of Material</b>	Fireclay

**Accessories**

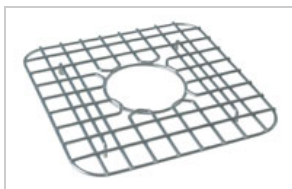

112.0066.221

**Suggested Products**



112.0048.590



115.0196.965