

SPECIFICATION SHEET

PRODUCT FAMILY: **Waste Management** FINISH: **other** SERIES: **WASTE DISPOSERS** MODEL: **FWD75R**

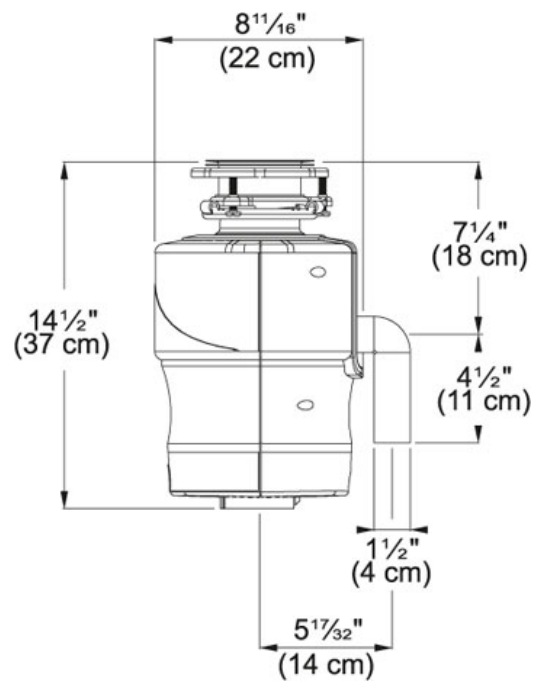

Product Information

FUN#	134.0297.203
US Part Number	FWD75R
RPM	2700
Horse Power	3/4 HP
*	Continuous Feed models may require Air Switch WD3428 and Controller WD9088. Chrome stopper and flange standard on each disposer not available separately. WD8026SN and WD8027C not compatible with this model.