

SPECIFICATION SHEET

PRODUCT FAMILY: **Waste Management** FINISH: **other** SERIES: **WASTE DISPOSERS** MODEL: **WD50RC**

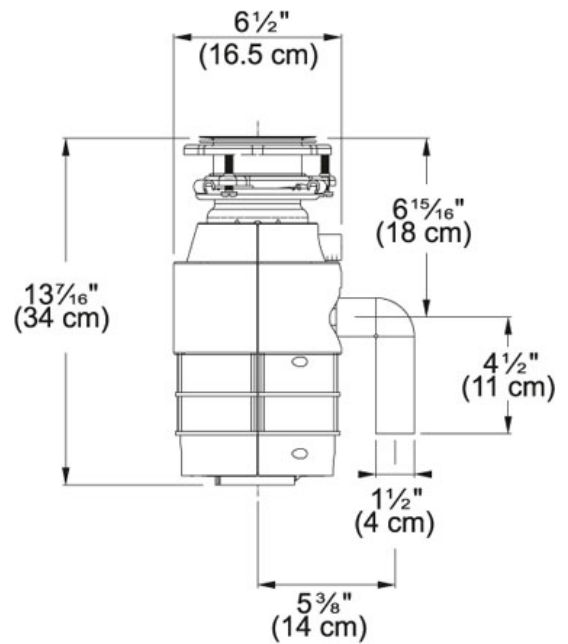

Product Information

FUN#	134.0319.572
US Part Number	WD50RC
RPM	2600
Horse Power	1/2 HP
*	Continuous Feed models may require Air Switch WD3428 and Controller WD9088. Chrome stopper and flange standard on each disposer not available separately. WD8026SN and WD8027C not compatible with this model. Includes power cord.