

24" Northland Built-in Undercounter All Refrigerator

Capable of storing as many as 190 cans, this high-efficiency Northland Undercounter Refrigerator features full-depth cantilever shelving for maximum capacity and versatile storage options.



Primary Features

- ENERGY STAR® certified
- Forced air cooling technology rapidly cools and ensures precise temperature stability
- Electronic controls provide temperature settings between 34°F to 42°F
- Perforated steel shelves allow cool air to efficiently circulate throughout the cabinet
- Daylight white lighting illuminates the rich midnight black interior
- Decorative stainless steel handle
- Right hinge only, non-reversible

Product Dimensions	23 7/8" w x 23 23/32" d x 33 3/4" h
Capacity	5.3 cu. ft.
Finish Options	Stainless Steel, Black
Interior Color	Black
Handle	Slim Stainless Steel Handle
Toe Grill Finish	Black
Hinge Type	Hinge Pin
Shelving	2 Cantilevered Shelves
Controls	Electronic
Temperature Range	34°F to 42°F
Door Lock	No
Electrical Requirements	115V / 60 Hz / 15A
Power Cord	6'
Shipping Weight	160 lbs
Agency Approvals	CSA
Warranty	1-year parts and labor warranty, 5-year sealed system parts warranty

Ordering Details

Product Description	Model Number
Solid Stainless Steel Door, Right Hinge	NL24RAS0RS
Solid Black Door, Right Hinge	NL24RAS0RB

Finish Options



Stainless Steel



Black



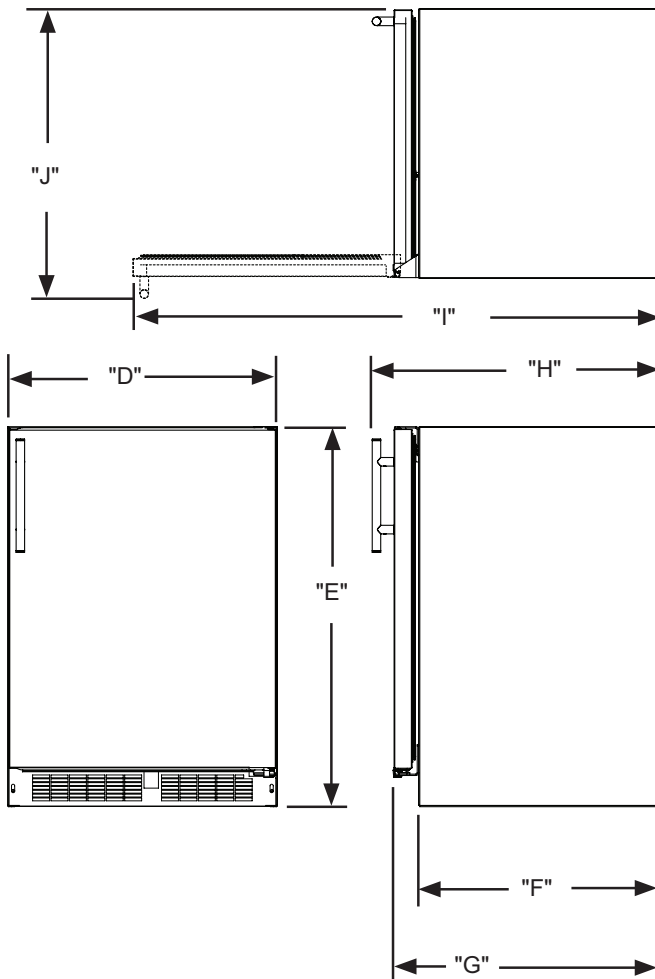
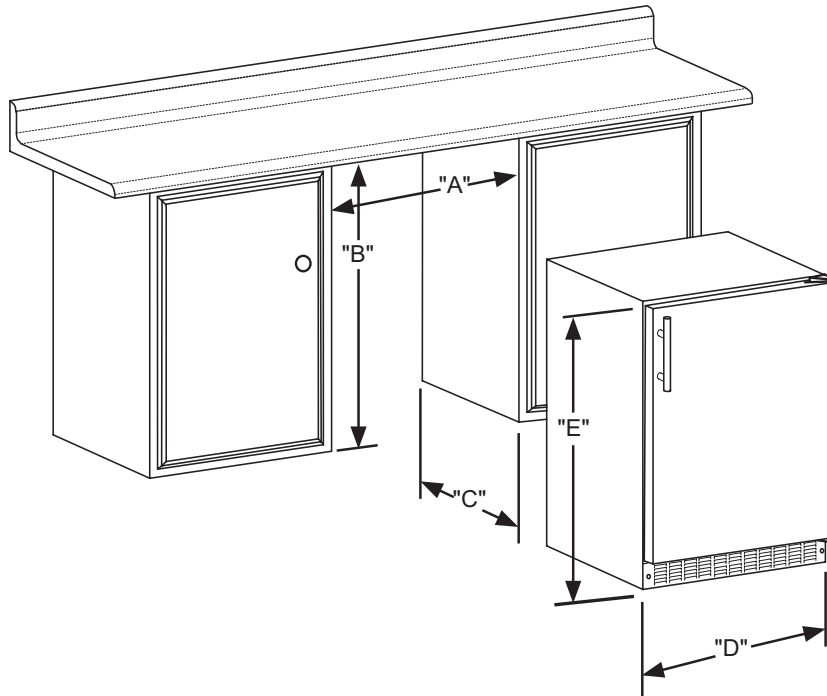

Rough-In Dimensions

A. Rough-In Width	24"
B. Rough-In Height	34" to 35"
C. Rough-In Depth	24"

Product Dimensions

D. Width	23 7/8"
E. Height	33 3/4" to 34 3/4"
F. Depth	21 1/2"
G. Depth to Front of Door	23 23/32"
H. Depth to Handle	26 7/32"
I. Depth with Door at 90°	46 13/32"

For comprehensive installation instructions, please visit northlandamerica.com to access the owner's guide.