



80 CFM Bath Fan Energy Star compliant

Bath Fans

Type _____
-30
PV020

Catalog No.	Finish White	Air Flow	Dimensions (Inches)		
			A	B	C
PV020	-30	80 CFM*	9-1/4	11-5/8	8

Ceiling Opening: 10-1/2" square
* Nominal rated flow rate at 0.1 "Ps

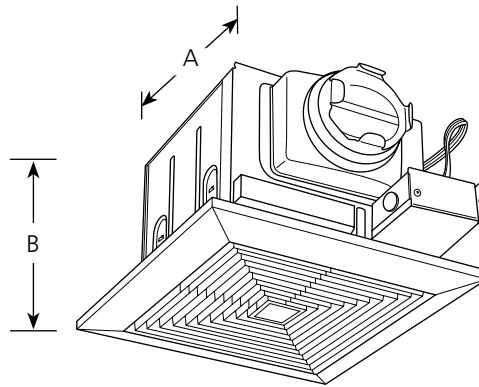

Specifications:

Performance at 0.1" Ps

- Air Flow: 93 CFM (60 CFM at 0.25" Ps)
- Fan Motor Speed: 958 RPM
- Sound: 0.7 Sones
- Power: 23.6W

Trim/Grille

- One piece white polymeric
- Mounts with two torsion springs to provide positive retention and eliminate ceiling gaps
- Dimensions: 12-3/4" sq., 7/8" deep

Housing

- Heavy gauge steel construction
- Black power coat painted finish
- Accommodates installation in 2x8 construction
- Mounts to ceiling or wall joists
- Galvanized steel construction
- Removable cover for access to wiring compartment
- 4" round duct fitting for positive connection
- Inline damper prevents cold backdrafts
- Bar hangers span 24" joist spacings in new construction
- Rigid steel rim accommodates remodel construction

Electrical

- 120v, 60Hz, 0.197A motor
- Permanently lubricated motor for continuous operation
- Plug in for ease of servicing
- Snaps in/out for ease of cleaning and servicing – no screws
- Specially designed polymeric blower wheel
- Thermally protected cut-off circuitry
- Energy Star certified

Labeling

- UL-CUL listed for use over bathtubs and showers when connected to a GFCI protected branch circuit
- Suitable for use in insulated ceilings (IC), max 40C ambient, insulation type not to exceed R40
- Air and Sound ratings are certified by HVI
- Energy Star Certified

Note: HVI-2100 certified ratings comply with current testing technologies and procedures by the Home Ventilating Institute for off the shelf products that are available to consumers. Product performance is rated at 0.1 in. static pressure, based on tests conducted in AMCA's state of the art test laboratory. Sones are a measure of humanly perceived loudness based on laboratory tests.



Progress Lighting
701 Millennium Blvd.
Greenville, South Carolina
29607

www.progresslighting.com