



Compact Fluorescent

Bath Fans
Energy Star compliant

Bath Fans

Type _____
-09STRWB

PV008

Catalog No.	Finish	Lamping	Capacity	Sones	Volts	Amps	Dimensions (Inches)	
	Brushed Nickel						A	B
PV008	-09STRWB	2 GU-24 13w (included)	70 CFM	2.5	120V	1.0	13-3/4	11

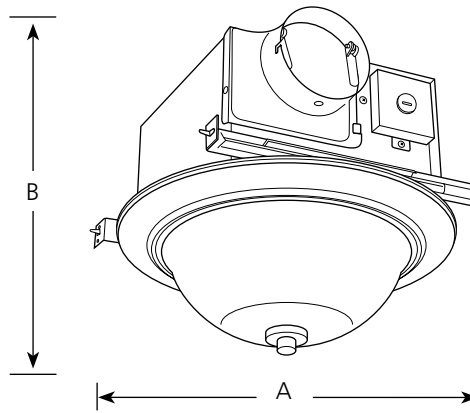

Specifications:

Trim/Grille

- One piece steel
- Center mount to housing
- Dimensions – 13” diameter and 5-9/16” deep (Including diffuser)

Diffuser

- Frosted glass
- Center mounts to Trim/Grille
- Center finial matches trim finish

Housing

- Mounts to ceiling joists, or in suspended ceilings
- Can be mounted in sloped ceilings up to a 12/12 pitch
- Galvanized steel
- 24 gage
- Mounting brackets with keyhole slots, and holes for ceiling wires
- Removable wiring cover for easy connections
- Internal wiring plate allows either top or side hole for conduit or BX fitter
- No KO’s to remove
- Tapered polymeric 4” round duct fitting for positive connection

Motor

- 120 volt, 1.0 amp, permanently lubricated
- Plug in for ease of servicing
- Snaps in or out for ease of cleaning and servicing – no screws
- Specially designed polymeric blower wheel

Lamping and ballast

- Two, 13 watt GU24, self-ballasted compact fluorescent lamps
- 2700K CCT

Labeling

- UL/CUL listed.
- Listed for use in insulated ceilings (IC listing)
- Energy Star Certified

Note: Product performance is rated at 0.1 in. static pressure, based on tests conducted in AMCA’s state of the art test laboratory. Sones are a measure of humanly perceived loudness based on laboratory tests.



Progress Lighting
701 Millennium Blvd.
Greenville, South Carolina
29607

www.progresslighting.com

Rev. 06/13