

INSTALLERS DIAGRAM

MODEL NUMBER:1142VA-24-220

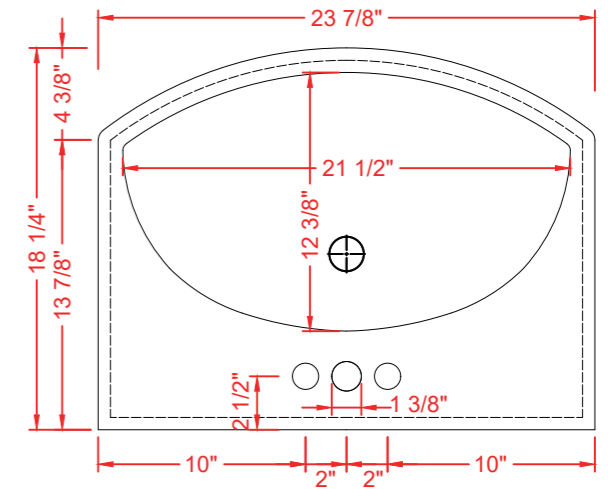
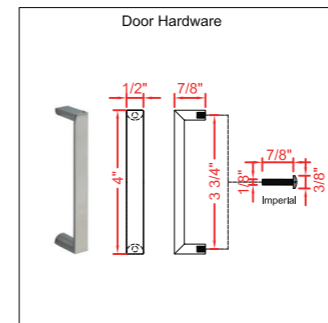
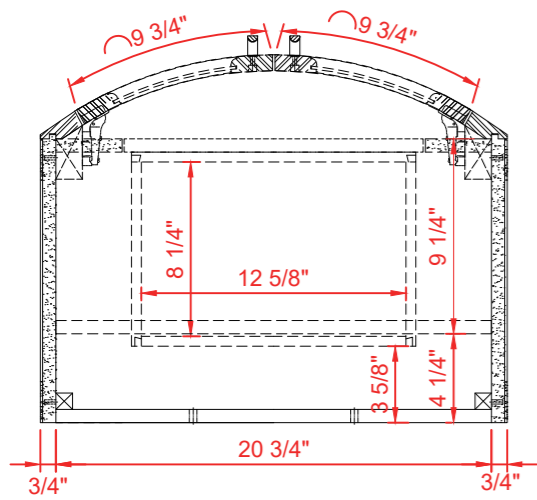

TOP VIEW

**Product Net weight :76lbs.
Product packed Gross weight :106lbs.
Packed product Dimensions:
26.75 in. W x 21.625 in. D x 39.5 in. H**

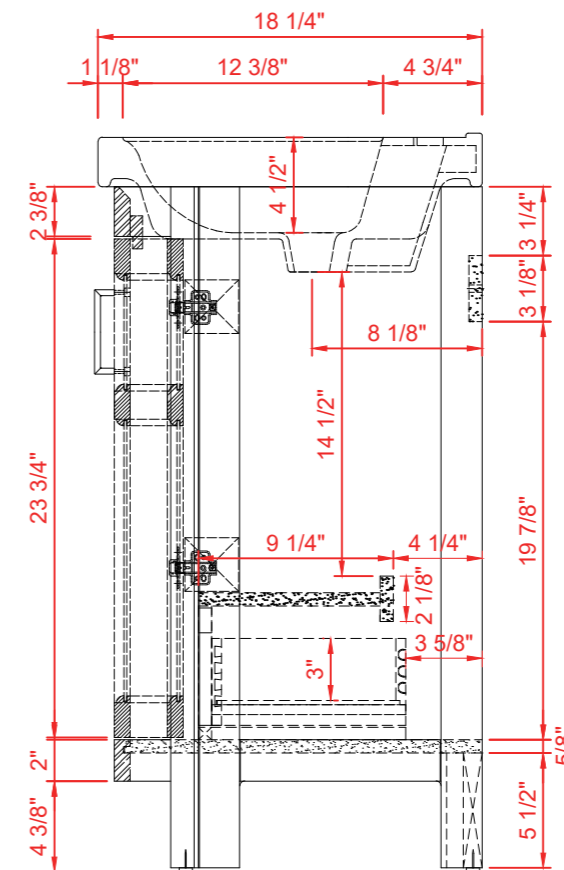
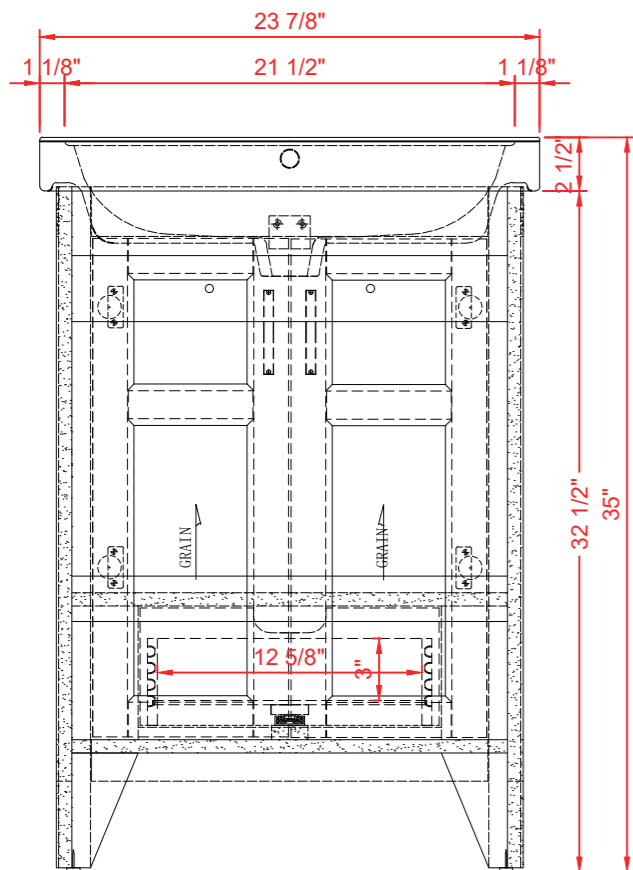

FRONT VIEW

SIDE VIEW