

24" Gas Cooktop

500 Series – Stainless Steel NGM5455UC

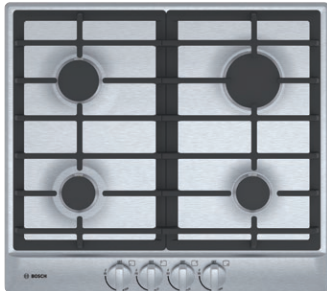

BOSCH
Invented for life



NGM5455UC

The 24" gas cooktop is engineered to perform by offering a 11,500 BTU burner and is ideal for kitchens with a smaller footprint.

Features & Benefits

Heavy-duty metal knobs for a premium look and feel.

Sealed burners prevent spills from entering the burner box.

Automatic re-ignition will turn the burner on in case the flame goes out.

Centralized controls for easy use and intuitive operation of the cooktop.

LP conversion kit is included.

General Properties

Knob material	Metal
Sealed burners	Yes
Grate material	Cast iron

Element Performance

Total BTU load (NG / LP)	30,600 / 27,000
Power of front left burner (NG / LP)	5,000 / 5,000
Power of back left burner (NG / LP)	9,100 / 7,000
Power of back right burner (NG / LP)	11,500 / 10,000
Power of front right burner (NG / LP)	5,000 / 5,000

Technical Details

Watts	360 W
Circuit breaker	15 A
Volts	120 V
Frequency	60 Hz
Plug type	3 prong
Power cord length	60"
Energy source	Gas
Convertible to LP (kit required)	Yes

Dimensions & Weight

Overall appliance dimensions (HxWxD)	3 3/4" x 23" x 20 1/2"
Required cutout size (HxWxD)	2 3/4" x 20 7/8" x 19 1/4"
Minimum distance from counter front	1 3/4"
Minimum distance from rear wall	3"
Net weight	31 1/2"

Accessories – Included

Included	LP conversion kit
----------	-------------------



For help and assistance with Bosch accessories please visit: www.bosch-eshop.com/eshop/bosch/us or call 1-800-944-2904 Mon-Fri 5am to 6pm PST Sat 6am to 3pm PST

Notes: All height, width and depth dimensions are shown in inches. BSH reserves the absolute and unrestricted right to change product materials and specifications, at any time, without notice. Consult the product's installation instructions for final dimensional data and other details prior to making cutout. Applicable product warranty can be found in accompanying product literature or you may contact your account manager for further details.

Warranties: Bosch warrants that the Product is free from defects in materials and workmanship for a period of three hundred and sixty-five (365) days from the date of purchase. The foregoing timeline begins to run upon the date of purchase, and shall not be stalled, tolled, extended, or suspended, for any reason whatsoever. This Product is also warranted to be free from cosmetic defects in material and workmanship (such as scratches of stainless steel, paint/porcelain blemishes, chip, dents, or other damage) to the finish of the Product, for a period of thirty (30) days from the date of purchase or closing date for new construction. This cosmetic warranty excludes slight color variations due to inherent differences in painted and porcelain parts, as well as differences caused by kitchen lighting, product location, or other similar factors. This cosmetic warranty specifically excludes any display, floor, "As Is", or "B" stock appliances.

For more information on our entire line of products, go to www.bosch-home.com/us or call 1-800-944-2904

© BSH Home Appliances Corporation. All rights reserved. Bosch is a registered trademark of Robert Bosch GmbH.

11/16

24" Gas Cooktop

500 Series – Stainless Steel NGM5455UC



BOSCH
Invented for life

Installation Details

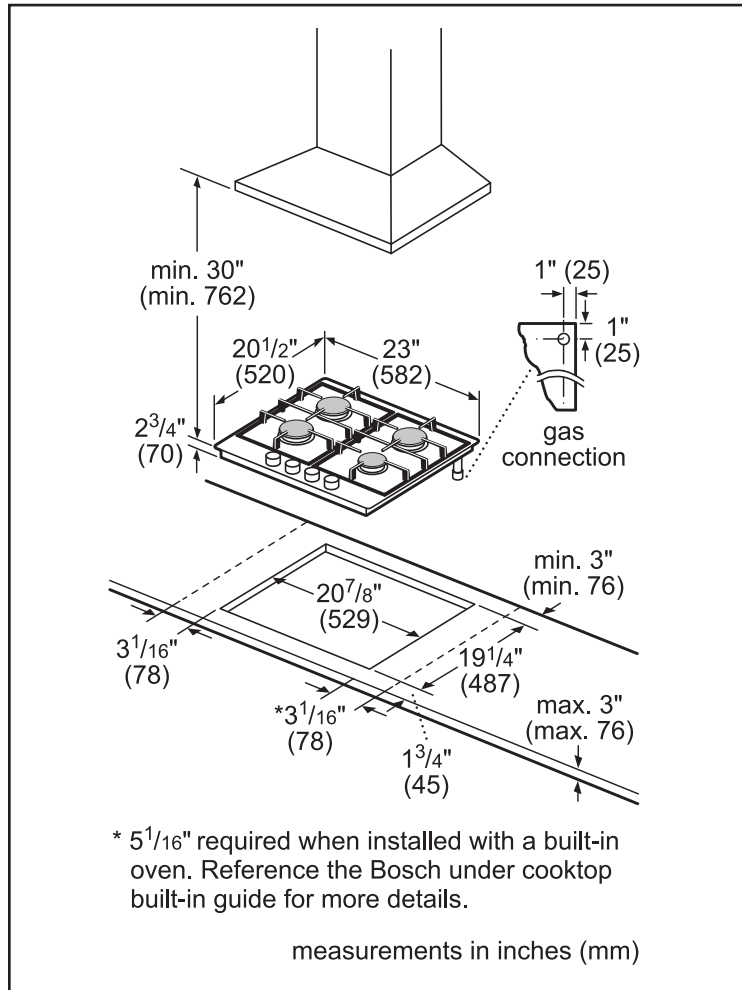

Installation above Wall Ovens

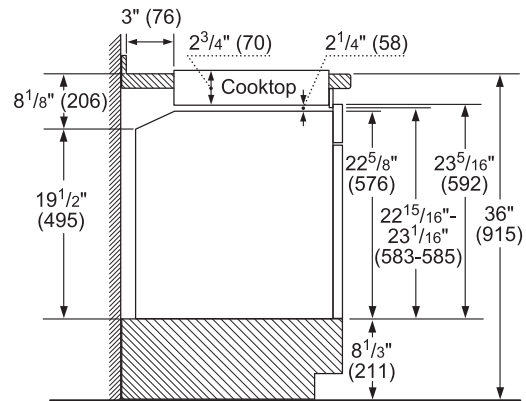

Notes: Dimensions based on standard countertop height (36" with 4³/₄" toe kick including base plate).

The built-in oven can be installed below the cooktop as long as there is at least 2¹/₄" (58) of space between the bottom flat surface of the cooktop and the top of the oven.

Please allow at least 2" (51) from the countertop front edge to the edge of the cutout.

measurements in inches (mm)

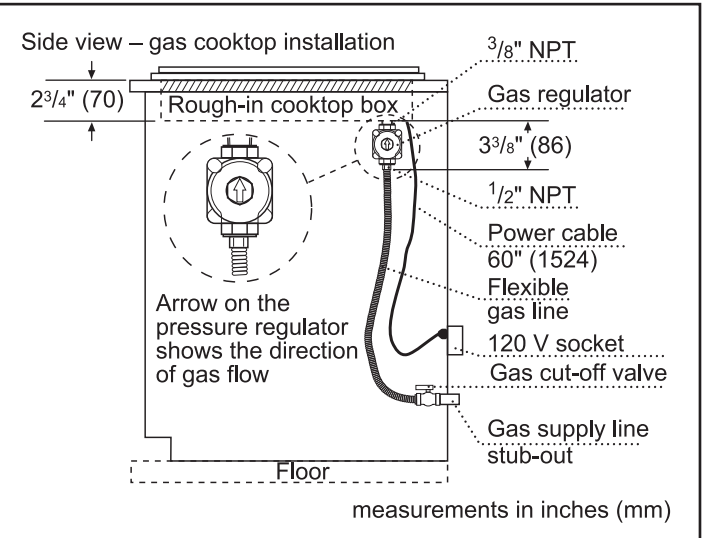

For help and assistance with Bosch accessories please visit: www.bosch-eshop.com/eshop/bosch/us or call 1-800-944-2904 Mon-Fri 5am to 6pm PST Sat 6am to 3pm PST

Notes: All height, width and depth dimensions are shown in inches. BSH reserves the absolute and unrestricted right to change product materials and specifications, at any time, without notice. Consult the product's installation instructions for final dimensional data and other details prior to making cutout. Applicable product warranty can be found in accompanying product literature or you may contact your account manager for further details.

Warranties: Bosch warrants that the Product is free from defects in materials and workmanship for a period of three hundred and sixty-five (365) days from the date of purchase. The foregoing timeline begins to run upon the date of purchase, and shall not be stalled, tolled, extended, or suspended, for any reason whatsoever. This Product is also warranted to be free from cosmetic defects in material and workmanship (such as scratches of stainless steel, paint/porcelain blemishes, chip, dents, or other damage) to the finish of the Product, for a period of thirty (30) days from the date of purchase or closing date for new construction. This cosmetic warranty excludes slight color variations due to inherent differences in painted and porcelain parts, as well as differences caused by kitchen lighting, product location, or other similar factors. This cosmetic warranty specifically excludes any display, floor, "As Is", or "B" stock appliances.

For more information on our entire line of products, go to www.bosch-home.com/us or call 1-800-944-2904

© BSH Home Appliances Corporation. All rights reserved. Bosch is a registered trademark of Robert Bosch GmbH.