

cod. FTN0100

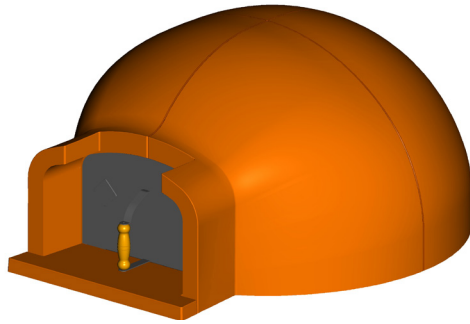

CARATTERISTICHE TECNICHE / TECHNICAL DETAILS

Peso / Weight	310 Kg / 683 Lbs
Area piano forno / Oven floor area	0,8 m <sup>2</sup> / 8,6 ft <sup>2</sup>
Minuti per scaldare / Heating time	55
N° pizze alla volta / Pizza capacity	5
Infnata di pane / Bread capacity	10 Kg / 22 Lbs
Consumo medio / Average fuel consumption	7 Kg/h / 15,4 Lbs/h
Temperatura massima / Max oven temperature	400 °C / 752 °F
Combustibile consigliato / Recommended fuel	Ciocchi, potature / Logs, trimmings

CANNA FUMARIA (inst. interna) / CHIMNEY (for indoor installation)

Altezza canna > 5 mt / Chimney height >16,4 ft	Altezza canna > 4 mt / Chimney height >13,1 ft	Altezza canna > 3 mt / Chimney height >9,8 ft
Diametro 15 cm oppure 15x15 cm / Diameter 5,9 In or 5,9x5,9 In	Diametro 20 cm oppure 20x20 cm / Diameter 7,8 In or 7,8x7,8 In	Diametro 25 cm oppure 25x25 cm / Diameter 9,8 In or 9,8x9,8 In

MISURE / DIMENSIONS

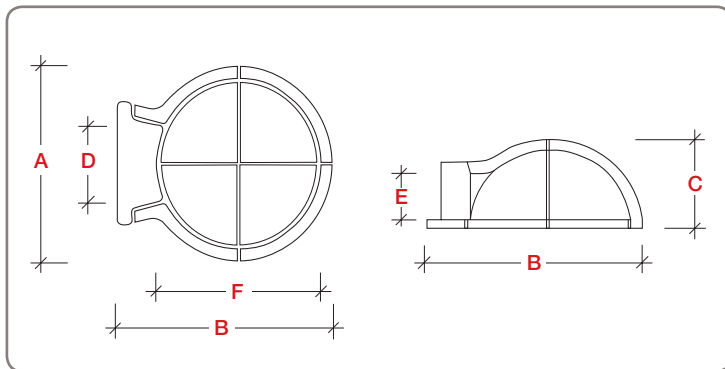

MISURE / DIMENSIONS

A	Larghezza totale / Total width	114 cm / 44,8 In
B	Lunghezza totale / Total length	132 cm / 51,9 In
C	Altezza totale / Total height	61 cm / 24 In
D	Larghezza bocca / Oven mouth width	48 cm / 18,9 In
E	Altezza bocca / Oven mouth height	30 cm / 11,8 In
F	Diametro interno / Inside diameter	100 cm / 39,3 In

MONTAGGIO e componenti / ASSEMBLY and parts list

	Cod.	N°	Desc.
a	XFDTN100	1	Davanzale T100
b	XFNSR50	4	Piano a spicchio r.50 T100
c	XFBN100D	1	Bocca DX T100
d	XFBN100S	1	Bocca SX T100
e	XFCN100	2	Cupola posteriore T100
f	YSPOT93	1	Sportello Tradizionale
g	YTE5040	1	Termometro d.50 I.40

N.B. Seguire l'ordine alfabetico per il montaggio del forno.