

Whirlpool® 30" Slide-in Gas Range

PRODUCT MODEL NUMBERS

GW397LXU

GW399LXU

Gas supply: Use 3/4" rigid pipe gas supply line to the range location. A smaller size pipe on long runs may result in insufficient gas supply. With L.P. gas, piping or tubing size can be 1/2" minimum. If local codes permit, it is recommended that new flexible metal tubing, design-certified by AGA or CSA, 1/2-inch or 3/4-inch I.D., be used for connecting the range to the rigid gas supply line. A 1/2" male pipe thread is needed for connection to pressure regulator female pipe threads. An individual manual shutoff valve must be located in the same room, but external to the range.

Electrical: A 120-volt, 60-Hz, AC-only, 10-ampere, electrical supply fused on both sides of the line. A separate circuit is recommended. A time-delay fuse or circuit breaker is recommended.

OVERALL DIMENSIONS

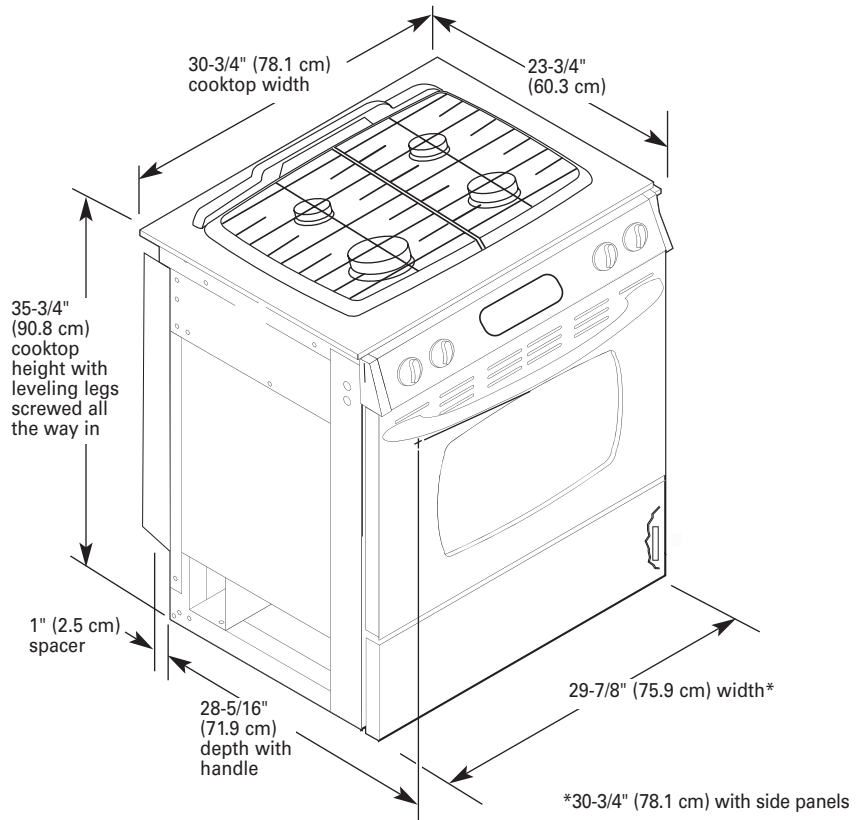

COUNTERTOP PREPERATION

The cooktop sides of the slide-in range fit over the cutout edge of your countertop.

If you have a square finish (flat) countertop and the opening width is 30" (76.2 cm), no countertop preparation is required.

Formed front-edged countertops: Must have molded edge shaved flat 3/8" (1.0 cm) from each front corner of opening.

Tile countertops may need trim cut back 3/8" (1.0 cm) from each front corner and/or rounded edge flattened.

If countertop opening width is greater than 30" (76.2 cm), adjust the 3/8" (1.0 cm) dimension.

Countertop must be level. Place level on countertop, first side to side; then front to back. If countertop is not level, range will not be level. Oven must be level for satisfactory baking conditions.

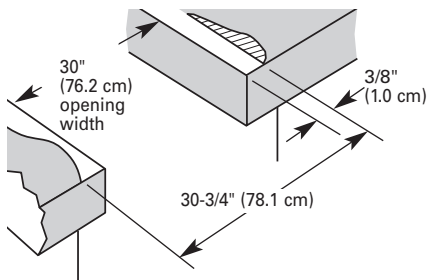

CABINET OPENING DIMENSIONS

Cabinet opening dimensions shown are for:

25" (64.0 cm) countertop depth, 24" (61.0 cm) base cabinet depth, 36" (91.4 cm) countertop height

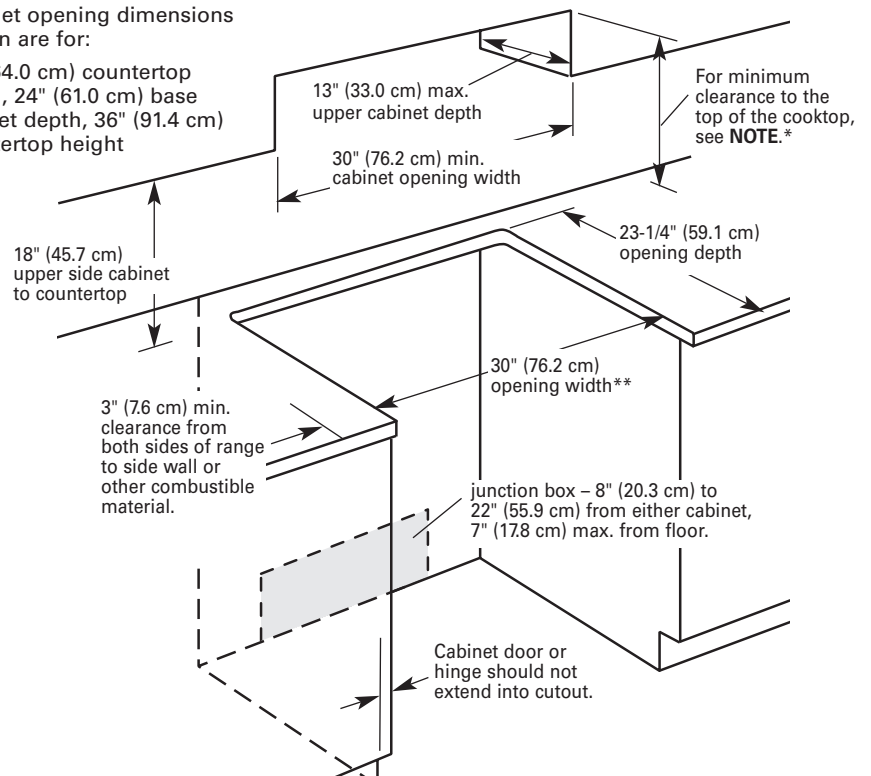

***NOTE:** 24" (61 cm) min. when bottom of wood or metal cabinet is protected by not less than 1/4" (6.4 mm) flame retardant millboard covered with not less than No. 28 MSG sheet steel, 0.015" (0.4 mm) stainless steel, 0.024" (0.6 mm) aluminum or 0.020" (0.5 mm) copper. 30" (76.2 cm) min. clearance between the top of the cooking platform and the bottom of an unprotected wood or metal cabinet.

**30-7/8" (78.4 cm) with side panels.