

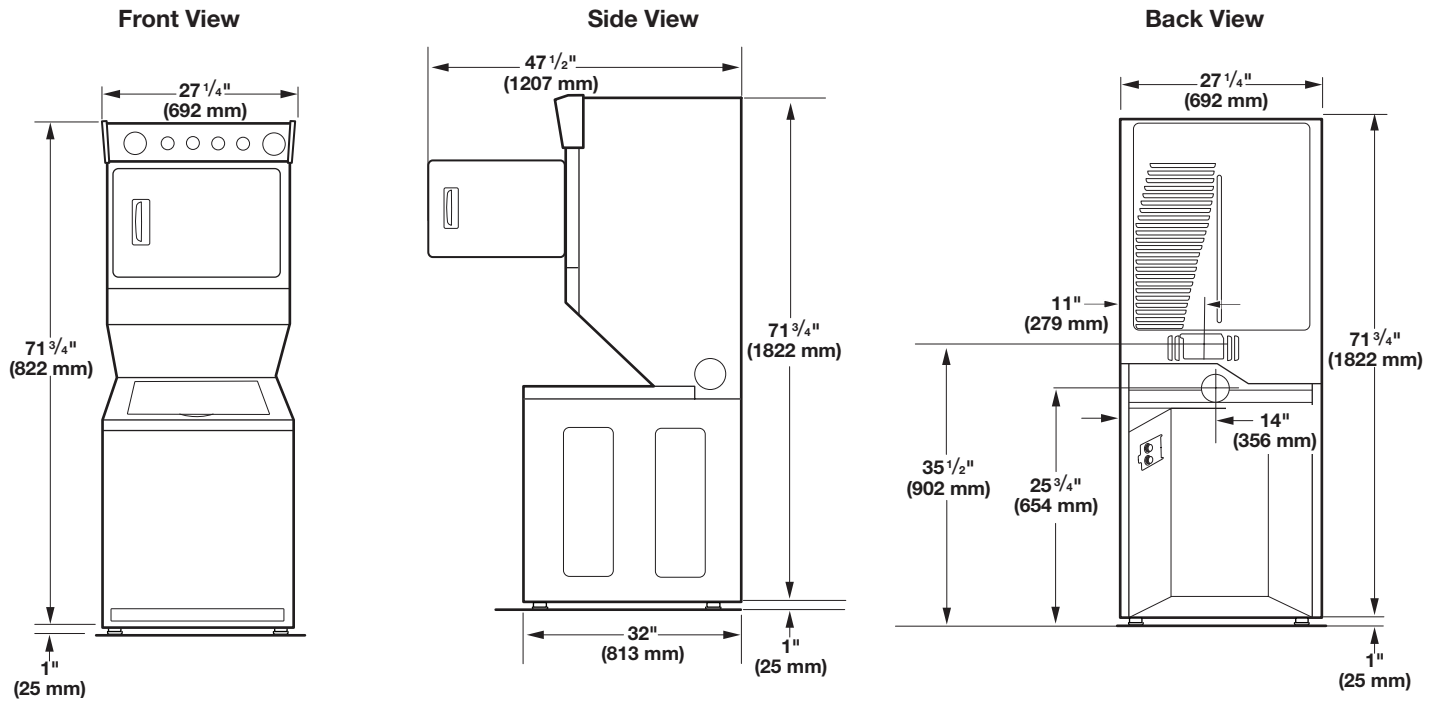

# 27" (69 cm) Electric Washer/Dryer

## PRODUCT MODEL NUMBERS WGT3300X

### Dimensions/Clearances



### Clearances

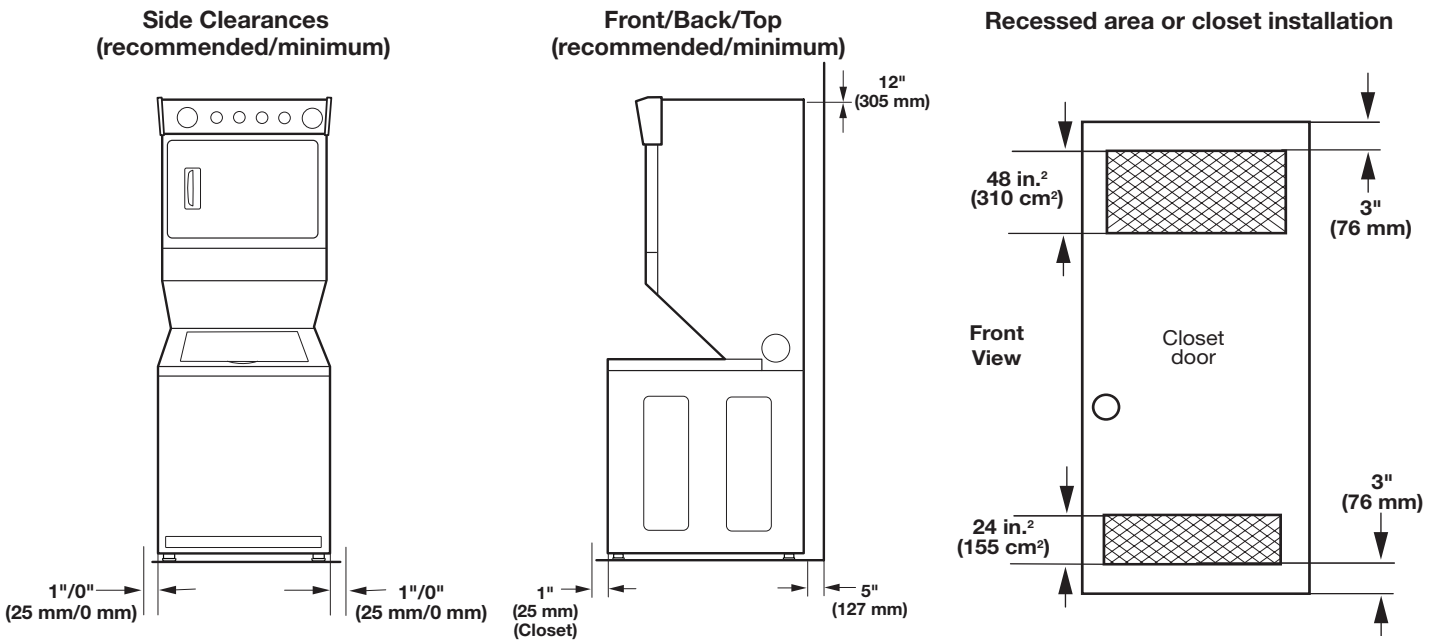

# ELECTRICAL REQUIREMENTS

To supply the required 3 or 4 wire, single phase, 120/240 volt, 60 Hz., AC only electrical supply (or 3 or 4 wire, 120/208 volt electrical supply, if specified on the serial/rating plate) on a separate 30-amp circuit, fused on both sides of the line. A time-delay fuse or circuit breaker is recommended. Connect to an individual branch circuit.

## DRAIN SYSTEM

Drain system can be installed using a floor drain, wall standpipe, floor standpipe, or laundry tub. Select method you need.

### Floor standpipe drain system

Minimum diameter for a standpipe drain: 2" (51 mm). Minimum carry-away capacity: 17 gal. (64 L) per minute. Top of standpipe must be at least 39" (990 mm) high; install no higher than 96" (2.4 m) from bottom of washer/dryer. If you must install higher than 96" (2.4 m), you will need a sump pump system.

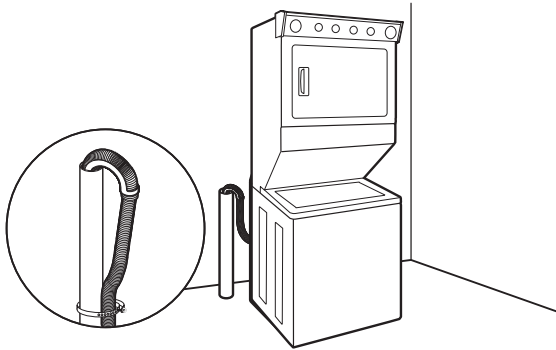

### Wall standpipe drain system

See requirements for floor standpipe drain system.

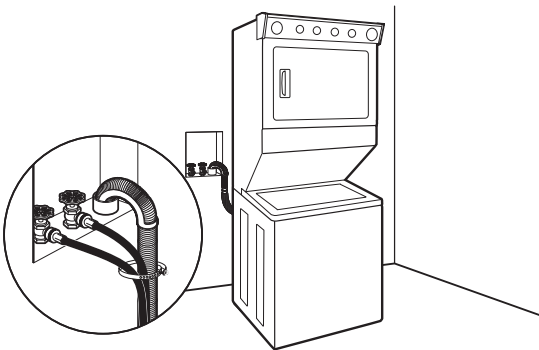

### Floor drain system

Floor drain system requires a Siphon Break Kit (Part Number 285834), 2 Connector Kits (Part Number 285385), and an Extension Drain Hose (Part Number 285863) that may be purchased separately. See "Use and Care Guide" for ordering details. Minimum siphon break: 28" (710 mm) from bottom of washer/dryer. (Additional hoses may be needed.)

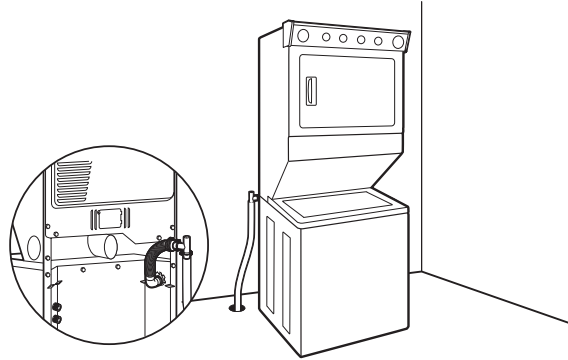

### Laundry tub drain system

Minimum capacity: 20 gal. (76 L). Top of laundry tub must be at least 39" (990 mm) above floor; install no higher than 96" (2.4 m) from bottom of washer/dryer.

**IMPORTANT:** To avoid siphoning, no more than 4.5" (113 mm) of drain hose should be inside standpipe or below the top of wash tub. Secure drain hose with shipping strap.

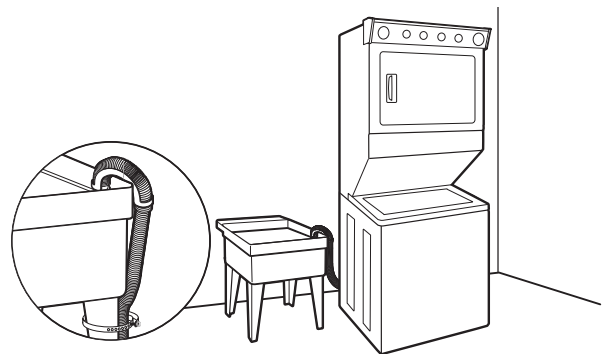

## VENTING REQUIREMENTS

**Exhaust venting:** Exhaust your dryer to the outside. 4" (102 mm) diameter vent is required. Rigid or flexible metal exhaust vent must be used. Do not use plastic or metal foil vet. Exhaust hood must be at least 12" (305 mm) from the ground or any object that may be in the path of the exhaust.

### Recommended Styles:

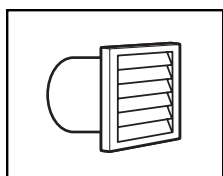

Louvered hood

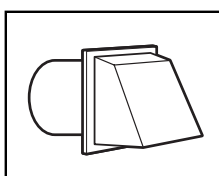

Box hood

### Acceptable Style:

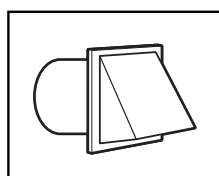

Angled hood

The "Vent System Chart" provides venting requirements that will help achieve best drying performance.

Vent System Chart			
Number of 90° turns or elbows	Type of vent	Box/louvered hoods	Angled hoods
0	Rigid metal	37 ft. (11.3 m)	35 ft. (10.7 m)
1	Rigid metal	32 ft. (9.7 m)	27 ft. (8.2 m)
2	Rigid metal	24 ft. (7.3 m)	19 ft. (5.8 m)

**NOTE:** Side exhaust installations have a 90° turn inside the dryer. To determine maximum exhaust length, add one 90° turn to the chart.