

## Location Requirements

**IMPORTANT:** Observe all governing codes and ordinances. Do not obstruct flow of combustion and ventilation air.

- It is the installer's responsibility to comply with installation clearances specified on the model/serial rating plate. The model/serial rating plate is located on the oven frame behind the top right side of the oven door.
- Recessed installations must provide complete enclosure of the sides and rear of the range.
- All openings in the wall or floor where range is to be installed must be sealed.
- Do not seal the range to the side cabinets.
- Cabinet opening dimensions that are shown must be used. Given dimensions are minimum clearances.
- The floor anti-tip bracket must be installed. To install the anti-tip bracket shipped with the range, see "Install Anti-Tip Bracket" section.
- Grounded electrical supply is required. See "Electrical Requirements" section.
- Proper gas supply connection must be available. See "Gas Supply Requirements" section.
- Contact a qualified floor covering installer to check that the floor covering can withstand at least 200°F (93°C).
- Use an insulated pad or ¼" (0.64 cm) plywood under range if installing range over carpeting.

**IMPORTANT:** To avoid damage to your cabinets, check with your builder or cabinet supplier to make sure that the materials used will not discolor, delaminate or sustain other damage. This oven has been designed in accordance with the requirements of UL and CSA International and complies with the maximum allowable wood cabinet temperatures of 194°F (90°C).

### Mobile Home - Additional Installation Requirements

The installation of this range must conform to the Manufactured Home Construction and Safety Standard, Title 24 CFR, Part 3280 (formerly the Federal Standard for Mobile Home Construction and Safety, Title 24, HUD Part 280). When such standard is not applicable, use the Standard for Manufactured Home Installations, ANSI A225.1/NFPA 501A or with local codes.

In Canada, the installation of this range must conform with the current standards CAN/CSA-Z240 - latest edition, or with local codes.

### Mobile home installations require:

- When this range is installed in a mobile home, it must be secured according to the instructions in this document.

## Product Dimensions

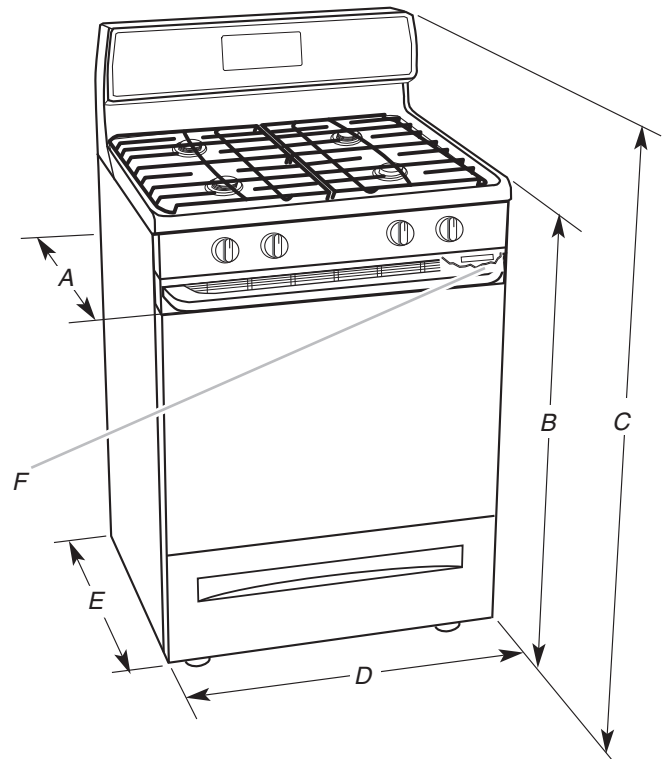

A. 27<sup>7</sup>/<sub>8</sub>" (70.8 cm) max. depth with handle

B. 36" (91.4 cm) cooktop height (max.) with leveling legs screwed all the way in\*

C. 46<sup>7</sup>/<sub>8</sub>" (119.1 cm) overall height (max.) with leveling legs screwed all the way in\*

D. 29<sup>7</sup>/<sub>8</sub>" (75.9 cm) width

E. 25<sup>7</sup>/<sub>16</sub>" (64.6 cm) depth. Back of range to front of cooktop\*\*

F. Model/serial rating plate (located on the oven frame behind the top right side of the oven door)

**IMPORTANT:** Range must be level after installation. Follow the instructions in the "Level Range" section. Using the cooktop as a reference for leveling the range is not recommended.

\*Range can be raised approximately 1" (2.5 cm) by adjusting the leveling legs.

\*\*Front of door and drawer may extend farther forward, depending on styling.