

DW80H9930US

Samsung Dishwasher

Features

- WaterWall™ System
- Quiet Operation: 44dBA
- Express Cycle: 60 Minutes
- Third Rack with FlexTray™
- Zone Booster
- Half-Load Cycle: Lower Rack
- ENERGY STAR® rated: 258 kWh/Year
- Hidden Heating Element
- Triple Filtration System
- Electronic Touch Sensor
- 3 Spray Wash Arms (Upper, Middle, Lower)
- 5 Wash Cycles and 5 Wash Options
- Fan Condensing Drying System
- 2-Piece Silverware Basket
- 2" Adjustable Racking System
- Stainless Steel Interior

Convenience

- Child Lock
- Rinse Refill Indicator
- Last Cycle Memory
- Four Sensors (Digital Water Leakage, Water Fill, Overflow, Turbidity)



WaterWall™ System



Third Rack with FlexTray™

Available Color



Stainless Steel

Signature Features

WATERWALL™ SYSTEM

- Powerful wall of water cleans hard-to-reach places.
- Ensures more even, thorough washing performance than conventional rotary-spraying systems.

THIRD RACK WITH FLEXTRAY™

- Silverware lays flat for better cleaning.
- Removable, flexible tray for easy loading and unloading.

ZONE BOOSTER

- Offers flexibility to wash all types of dishes in one load.
- Select to wash right or left zone on the bottom rack.

HALF-LOAD CYCLE: LOWER

- Wash setting for half-load: lower rack only.
- Saves water, time and energy.

SAMSUNG

DW80H9930US

Samsung Dishwasher

Installing Your Dishwasher

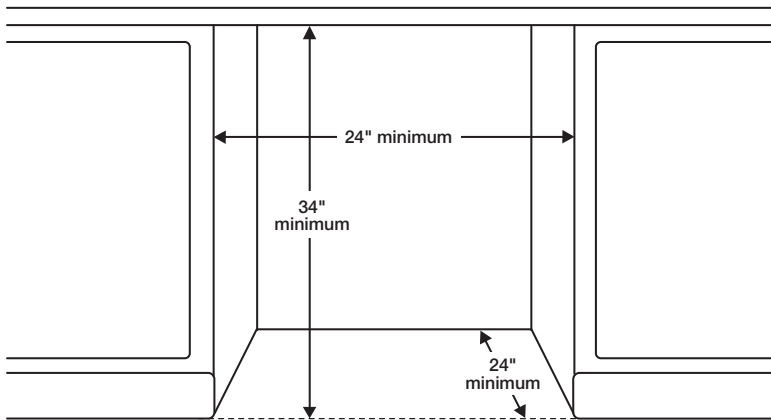

Dimensions

Side View

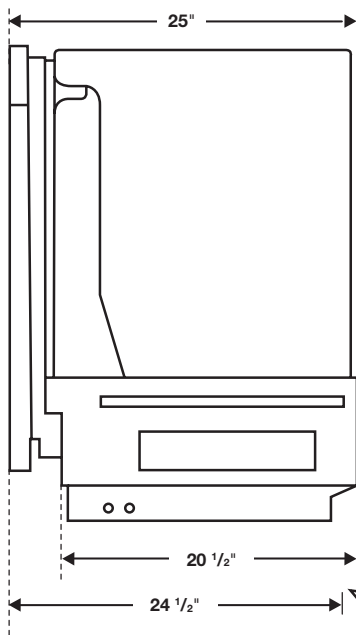

Rear View

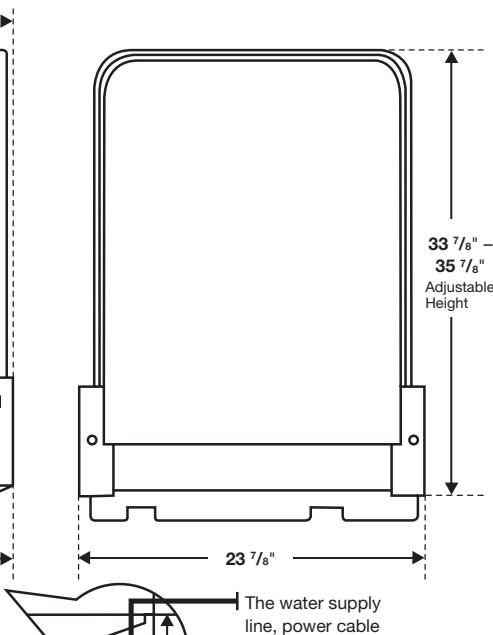

Performance

- 5 Wash Cycles: Auto, Normal, Heavy, Delicate, Express 60
- 5 Options: Half-Load Wash, Targeted Wash, Sanitize (Anti-Bacterial-NSF), Dry+, Delay Start
- 4 Control Buttons: Sound off, Child Lock, Start & Pause, Cancel and Drain
- 3 Filter System
- Hidden Heat Element
- Stainless Steel Interior Tub

Convenience Features

- Child Lock
- Digital Water Leakage Sensor.
- Third Rack with FlexTray™
- Nylon Racking
- 2 Piece Silverware Basket
- Upper Rack: 2 Cup Shelves, 3 Adjustable Tines
- Upper Rack: 2 Fold Down Tine
- Lower Rack: 6 Fold Down Tine
- Silverware basket

Warranty

Five (5) Years Limited on Linear Motion Parts, Printed Circuit Board and Interior Nylon Racks. Lifetime Limited Warranty on Stainless Steel Door Liner and Tub for Leakage.

Product Dimensions & Weight (WxHxD)

Dimensions:
24" x 33⁷/₈" x 24²/₃" (27" with handle)

Weight: 101 lbs.

Shipping Dimensions & Weight (WxHxD)

Dimensions:
26¹/₁₆" x 34²⁷/₃₂" x 29¹/₈"

Weight: 108 lbs.

| Color | Model # | UPC Code |
|-----------------|-------------|--------------|
| Stainless Steel | DW80H9930US | 887276683386 |

SAMSUNG

Actual color may vary. Design, specifications, and color availability are subject to change without notice. Non-metric weights and measurements are approximate.

©2013 Samsung Electronics America, Inc. 85 Challenger Road, Ridgefield Park, NJ 07660. Tel: 800-SAMSUNG. samsung.com. Samsung is a registered trademark of Samsung Electronics Co. Ltd.