

CK171000TX

Hendrik Cocktail Table Trunk

Assembly Instructions



Southern
ENTERPRISES

For assistance with assembly, contact:
Southern Enterprises Inc.
Customer Service: 1-800-633-5096
service@seidal.com
www.seidal.com



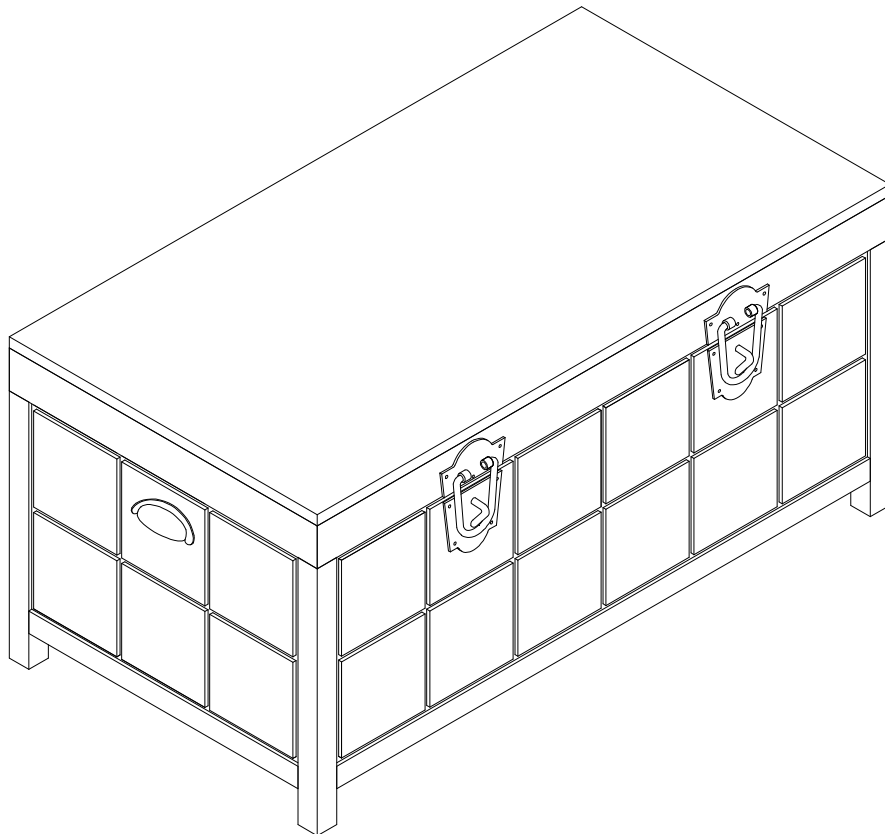

PO#:

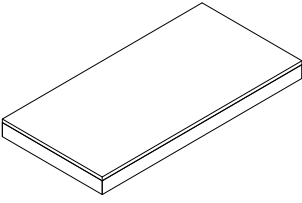
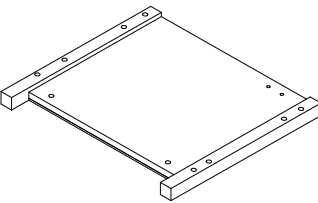
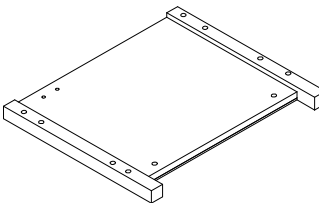
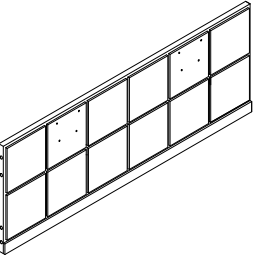
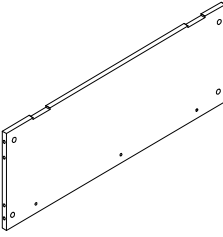
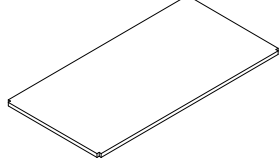

Hendrik Cocktail Table Trunk

Parts List

Please review all parts and hardware before disposing of any packaging. Before beginning assembly, separate each type of hardware. Carefully study the diagrams below and check that you have all parts indicated. Call Customer Service if missing hardware. Using the incorrect hardware will cause damage. You may receive extra hardware with your unit.

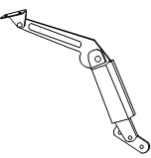
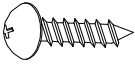
<p>1. Quantity of 1</p>  <p>Top Panel</p>	<p>2. Quantity of 1</p>  <p>Left Side Panel</p>	<p>3. Quantity of 1</p>  <p>Right Side Panel</p>
<p>4. Quantity of 1</p>  <p>Front Panel</p>	<p>5. Quantity of 1</p>  <p>Back Panel</p>	<p>6. Quantity of 1</p>  <p>Bottom Panel</p>
<p>A. Quantity of 18</p>  <p>Cam Bolts</p>	<p>B. Quantity of 18</p>  <p>Cam Locks</p>	<p>C. Quantity of 8</p>  <p>Wood Dowels Dia 8mm x 30mm</p>
<p>D. Quantity of 1</p>  <p>Left-Arm Hinge</p>	<p>E. Quantity of 1</p>  <p>Right-Arm Hinge</p>	<p>F. Quantity of 22</p>  <p>Screws $\text{Ø } 1/8" \times 1/2" \text{L}$</p>

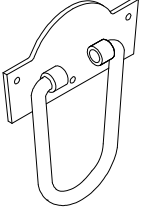
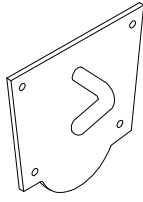
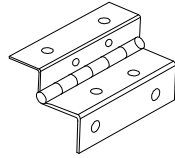
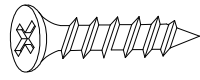
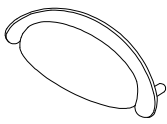
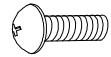
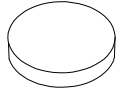
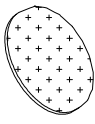
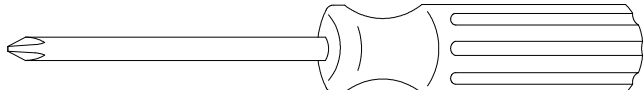
<p>G. Quantity of 2</p>  <p>Front Knobs-A</p>	<p>H. Quantity of 2</p>  <p>Front Knobs-B</p>	<p>I. Quantity of 2</p>  <p>Hinges</p>
<p>J. Quantity of 16</p>  <p>Screws \varnothing 1/8" x 1/2"L</p>	<p>K. Quantity of 2</p>  <p>Side Handles</p>	<p>L. Quantity of 4</p>  <p>Bolts \varnothing 5/32" x 1/2"L</p>
<p>M. Quantity of 3</p>  <p>Adhesive Pads</p>	<p>N. Quantity of 8</p>  <p>Cotton Mats</p>	
<p>Care and Cleaning Instructions: Before using, wipe with a clean, dry cloth. Periodically apply furniture wax to renew the finish. Avoid rubbing or scratching the surface with rough or abrasive objects.</p>		<p>For replacement parts or questions, please call Customer Service at 1-800-633-5096.</p>
<p>Assembly Tool Required No.2 Phillips Screwdriver (Not Included)</p>		

Hendrik Cocktail Table Trunk

Assembly Instructions

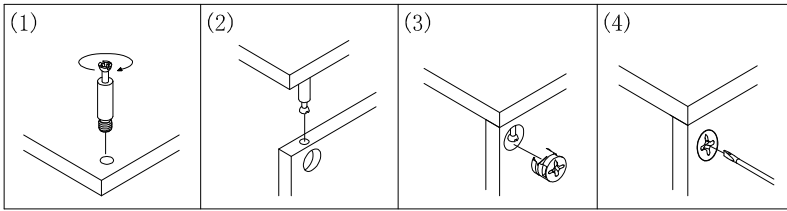

"Please do not over tighten cambolts. Please stop when you feel tight"

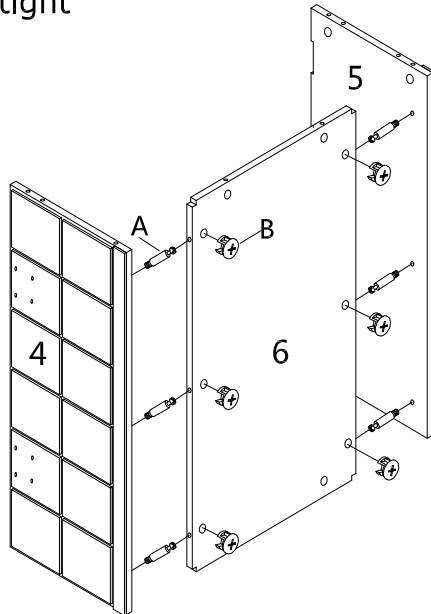

Figure 1

Start screwing with fingers to help align Cam Bolts.

Screw Cam Bolts **(A)** into holes on Front Panel **(4)** and Back Panel **(5)**.

Attach Front Panel **(4)** and Back Panel **(5)** to Bottom Panel **(6)** by inserting Cam Bolts **(A)** into corresponding holes.

Insert Cam Locks **(B)** into holes on Bottom Panel **(6)**.

Tighten by rotating Cam Locks **(B)** clockwise with Phillips screwdriver.

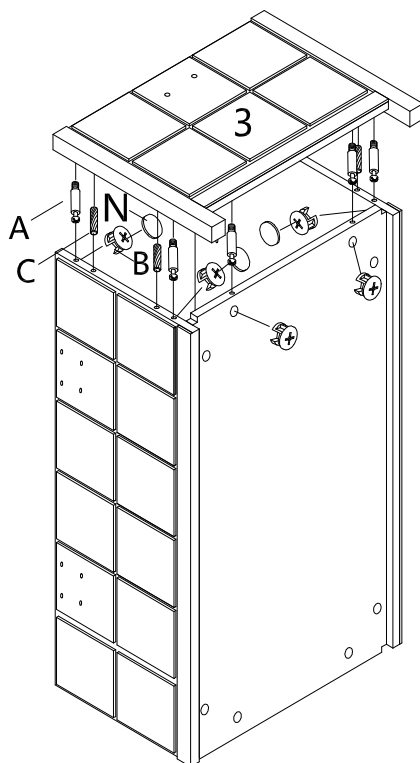

Figure 2

Screw Cam Bolts **(A)** and insert Wood Dowels **(C)** into holes on Right Side Panel **(3)**.

Attach Right Side Panel **(3)** to assembled unit from Figure 1 by inserting Cam Bolts **(A)** and Wood Dowels **(C)** into corresponding holes.

Insert Cam Locks **(B)** into holes on Bottom Panel **(6)**, Front Panel **(4)** and Back Panel **(5)**.

Tighten by rotating Cam Locks **(B)** clockwise with Phillips screwdriver.

Cover Cam Locks **(B)** with Cotton Mats **(N)** as shown.

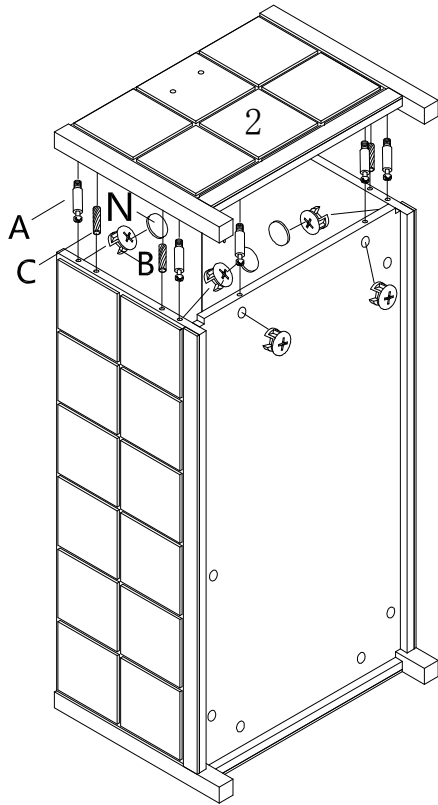

Screw Cam Bolts **(A)** and insert Wood Dowels **(C)** into holes on Left Side Panel **(2)**.

Attach Left Side Panel **(2)** to assembled unit by inserting Cam Bolts **(A)** and Wood Dowels **(C)** into corresponding holes.

Insert Cam Locks **(B)** into holes on Bottom Panel **(6)**, Front Panel **(4)** and Back Panel **(5)**.

Tighten by rotating Cam Locks **(B)** clockwise with Phillips screwdriver.

Cover Cam Locks **(B)** with Cotton Mats **(N)** as shown.

Figure 3

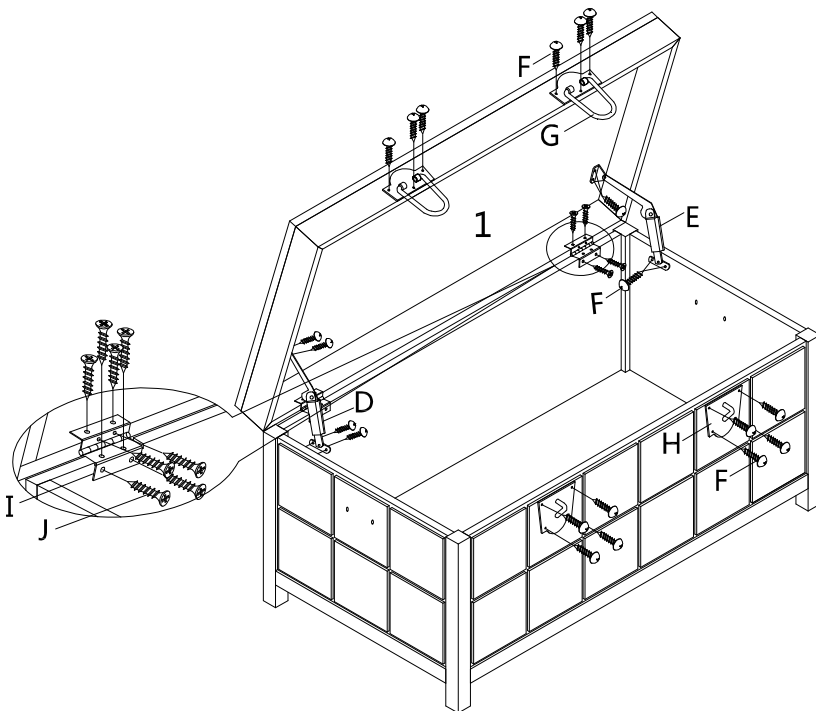

Attach Hinges **(I)** to Back Panel **(5)** and Top **(1)** using Screws **(J)** as shown.

Open Top **(1)** and attach Arm Hinge **(D/E)** to Top **(1)** and trunk base using screws **(F)**.

Attach Front Knobs **(G/H)** to Front Panel **(4)** and Top **(1)** using Screws **(F)**.

Tighten all screw with Phillips screwdriver.

Figure 4

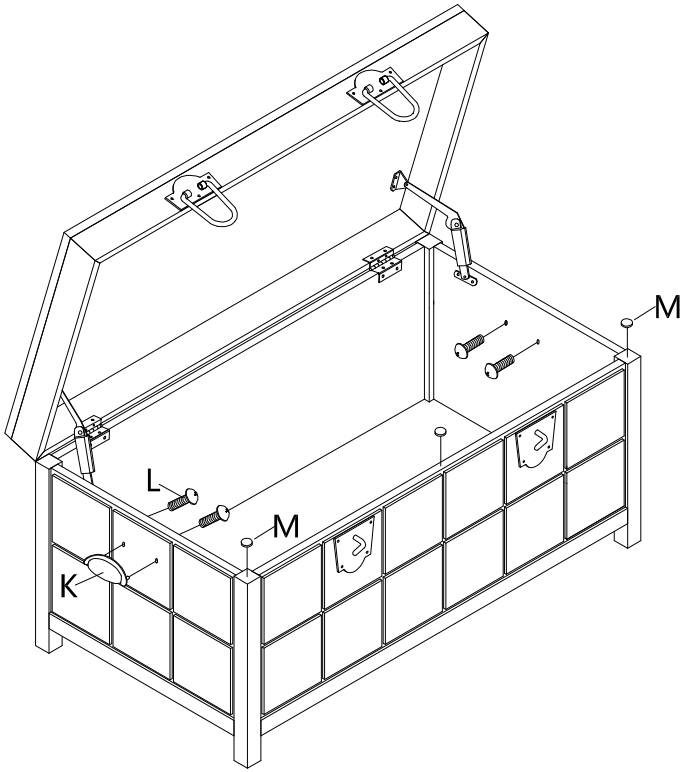

Figure 5

Start with finger to help align Bolts.

Attach Side Knobs (**K**) to Side Panels (**2/3**) using Bolts (**L**).

Tighten Bolts with Phillips screwdriver.

Place Adhesive Pads (**M**) on top corners of Front Panel (**4**) as shown.

Close Top (**1**) and let it drop down slowly.

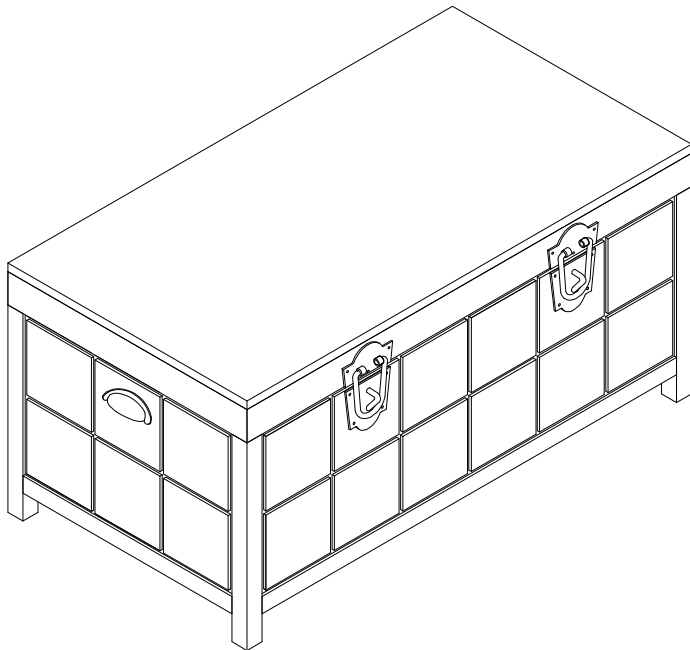

Figure 6

Now your Hendrik Cocktail Table Trunk is ready to use!

Parts Replacement Form

Customer Information

Name _____

Address _____

City/State/Zip Code _____

Phone Number _____

Please indicate where you purchased this item: Store/Website/Catalog

Please indicate color/size/style number:

Style No	Parts Letter	Parts Description	Quantity Needed
_____	_____	_____	_____
_____	_____	_____	_____
_____	_____	_____	_____

Please immediately examine this product carefully. Any request for missing parts or damage replacement must be received within 90 days of your receipt of the product. Replacement, if available, will be honored within this time frame. Parts will not be available for items arriving fully assembled. We do not recommend modifying product(s) and we are not responsible for any damages due to product modification(s). If damages or missing parts are not reported within 90 days of your receipt, we are under no obligation to provide parts or replacement merchandise.

For product issues, please contact Southern Enterprises at 800-633-5096 (toll-free) / 972-869-0111 (Dallas), Mon-Fri 9am – 4pm CST, or email us at service@seidal.com. Please ask for customer service representative for issues involving damages or replacement parts. Please ask for technical assistance representative for any issues with product and assembly/construction.

Please contact the retailer that you purchased from for returns.



Southern
ENTERPRISES

Customer Service: 1-800-633-5096
service@seidal.com

Southern Enterprises, Inc.
600 Freeport Parkway, Suite 200
Coppell, Texas 75019