

CK955000TX

Radcliff Cocktail

Assembly Instructions



Southern
ENTERPRISES

For assistance with assembly, contact:
Southern Enterprises, Inc.
Customer Service 1-800-633-5096
service@seidal.com
www.seidal.com

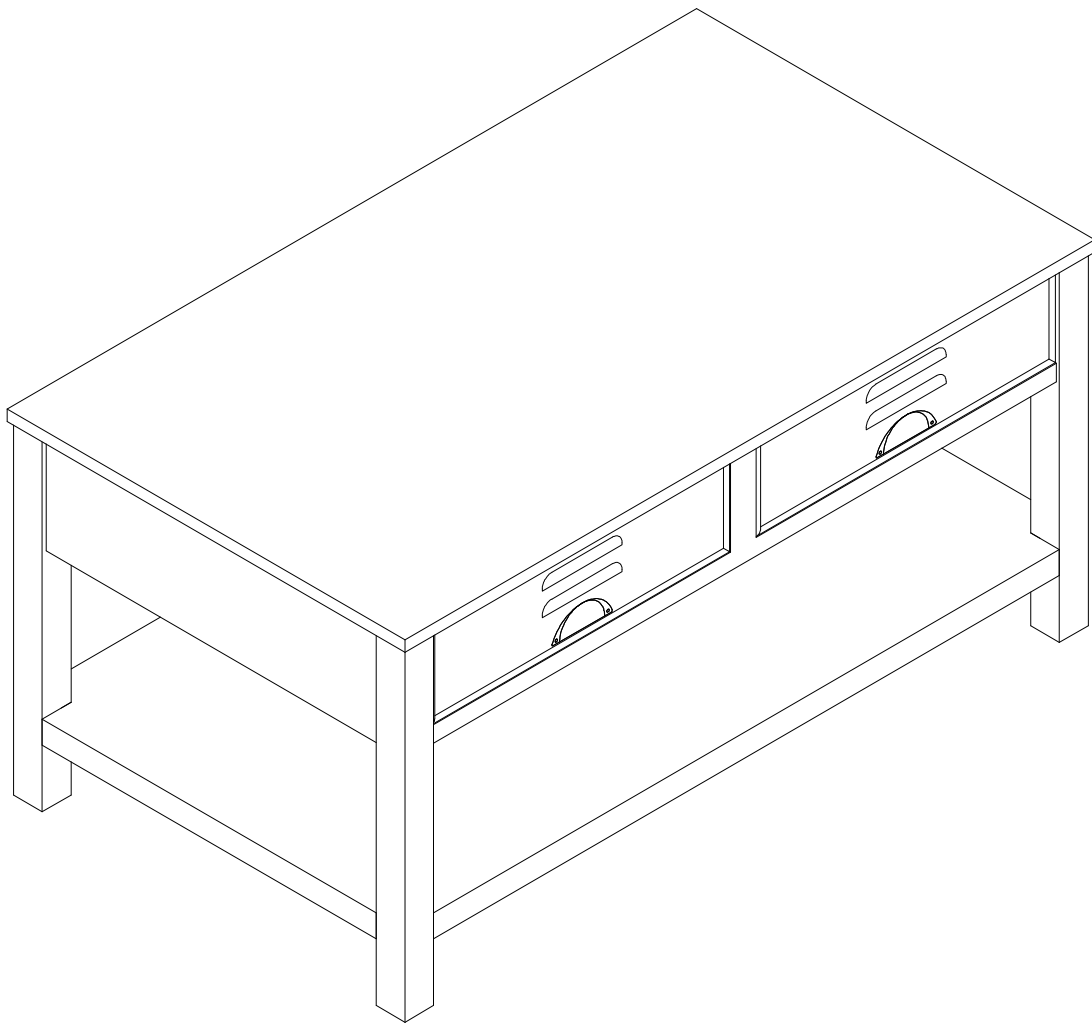

PO#:



Radcliff Cocktail

Parts List

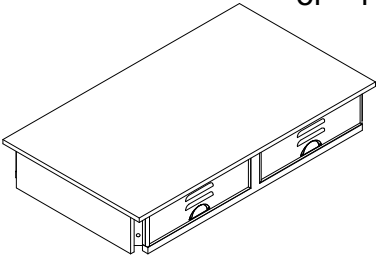
Please check packaging for all parts and hardware before discarding. Unpack and lay parts on clean, padded surface like carpet or blanket. Check that you have all parts indicated. Call customer service if hardware is missing. Before beginning assembly, carefully study the diagrams below and sort your hardware according to the pictures. Using the incorrect hardware will cause damage.

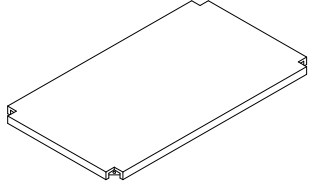
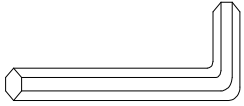
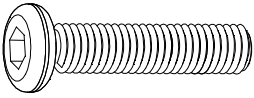
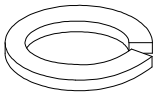
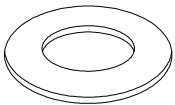
<p>A. Quantity of 1</p>  <p>Top Frame</p>	<p>B. Quantity of 4</p>  <p>Legs</p>	<p>C. Quantity of 1</p>  <p>Shelf Panel</p>
<p>1. Quantity of 1</p>  <p>Allen Wrench</p>	<p>2. Quantity of 12</p>  <p>Bolts $\text{Ø } 5/16\text{''} \times 2\text{''} \text{L}$</p>	<p>3. Quantity of 12</p>  <p>Spring Washers $\text{Ø } 5/16$</p>
<p>4. Quantity of 12</p>  <p>Flat Washers $\text{Ø } 5/16$</p>		

Care and Cleaning Instructions:
 Before using, wipe with a clean, dry cloth. Periodically apply furniture wax to renew the finish. Avoid rubbing or scratching the surface with rough or abrasive objects.

For replacement parts or questions, please call customer service at 1-800-633-5096.

Assembly Tool Required No.2 Phillips Screwdriver (Not Included)

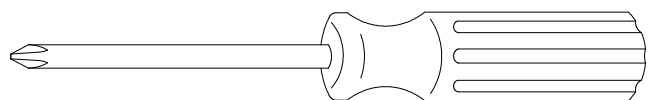

Radcliff Cocktail Assembly Instructions

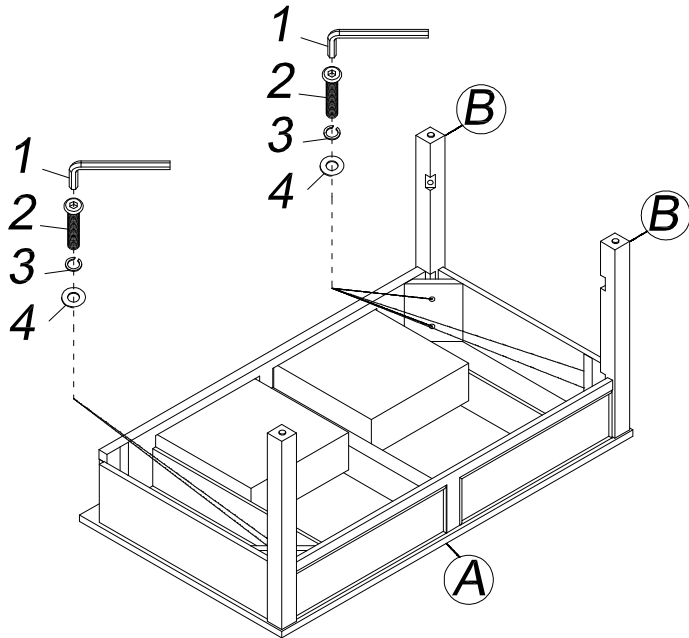

Figure 1

Attach three Legs (**B**) to Top Frame (**A**) with Bolts (**2**), Spring Washers (**3**), and Flat Washers (**4**).

Slightly tighten all Bolts (**2**) by using Allen Wrench (**1**) as shown. Do not fully tighten until you've assembly.

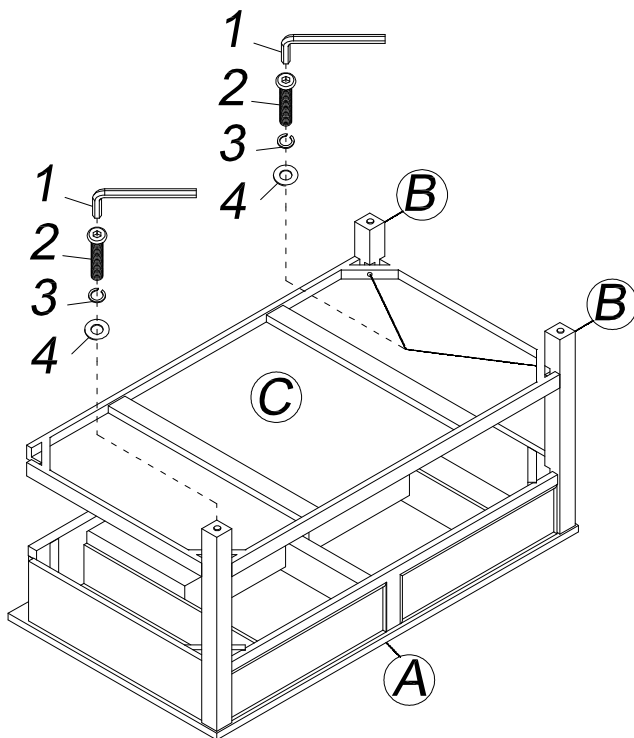

Figure 2

Attach Shelf Panel (**C**) to assemble unit from Figure 1 with Bolts (**2**), Spring Washers (**3**), and Flat Washers (**4**).

Slightly tighten Bolts (**2**) using Allen Wrench (**1**) as shown.

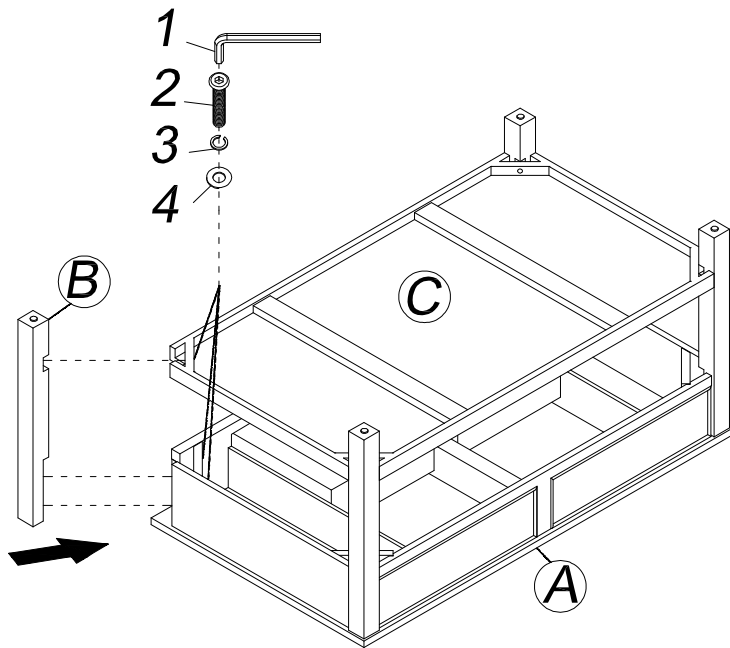

Figure 3

Attach the fourth Leg **(B)** to the assemble unit from Figure 2 with Bolts **(2)**, Spring Washers **(3)**, and Flat Washers **(4)**.

Fully tighten all Bolts **(2)** using Allen Wrench **(1)** as shown.

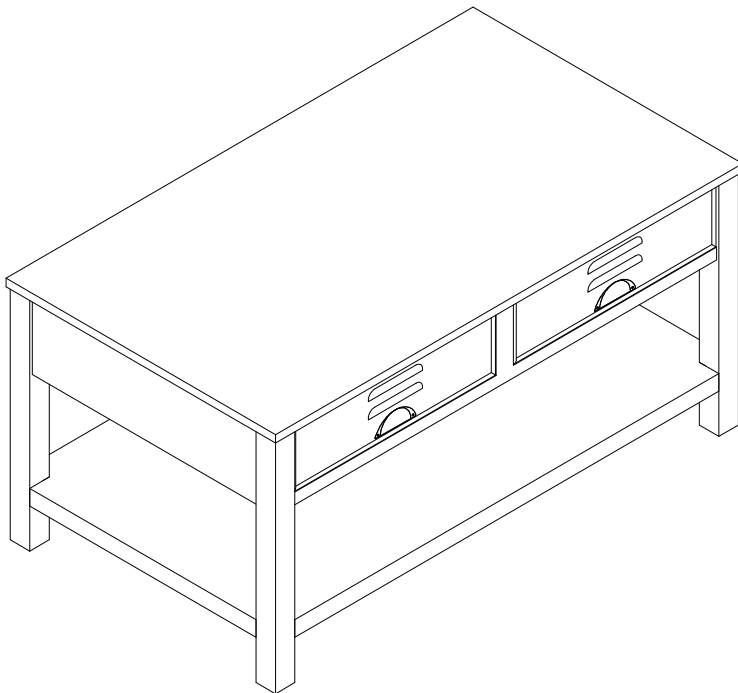

Figure 4

Now your Radcliff cocktail is ready to use.

Parts Replacement Form

Customer Information

Name _____

Address _____

City/State/Zip Code _____

Phone Number _____

Please indicate where you purchased this item: Store/Website/Catalog

Please indicate color/size/style number:

Style No	Parts Letter	Parts Description	Quantity Needed
_____	_____	_____	_____
_____	_____	_____	_____
_____	_____	_____	_____

Please immediately examine this product carefully. Any request for missing parts or damage replacement must be received within 90 days of your receipt of the product. Replacement, if available, will be honored within this time frame. Parts will not be available for items arriving fully assembled. We do not recommend modifying product(s) and we are not responsible for any damages due to product modification(s). If damages or missing parts are not reported within 90 days of your receipt, we are under no obligation to provide parts or replacement merchandise.

Please contact Southern Enterprises at 800-633-5096 or in Dallas 972-869-0111/ 9am – 4pm Mon-Fri Central time if you have product issues or email us at service@seidal.com. Please ask for customer service representative for issues involving damages or replacement parts. Please ask for technical assistance representative for any issues with product and assembly/construction.

Please contact the retailer that you purchased from for returns.



Southern
ENTERPRISES

Customer Service 1-800-633-5096
service@seidal.com
Southern Enterprises, Inc.
600 Freeport Parkway, Suite 200
Coppell, Texas 75019