

CK503000TX

GLYNN COCKTAIL

Assembly Instructions



Southern
ENTERPRISES

For assistance with assembly, contact.
Southern Enterprises Inc.
Customer Service 1-800-633-5096
service@seidal.com
www.seidal.com

PO:13876

Top supports up to lb.

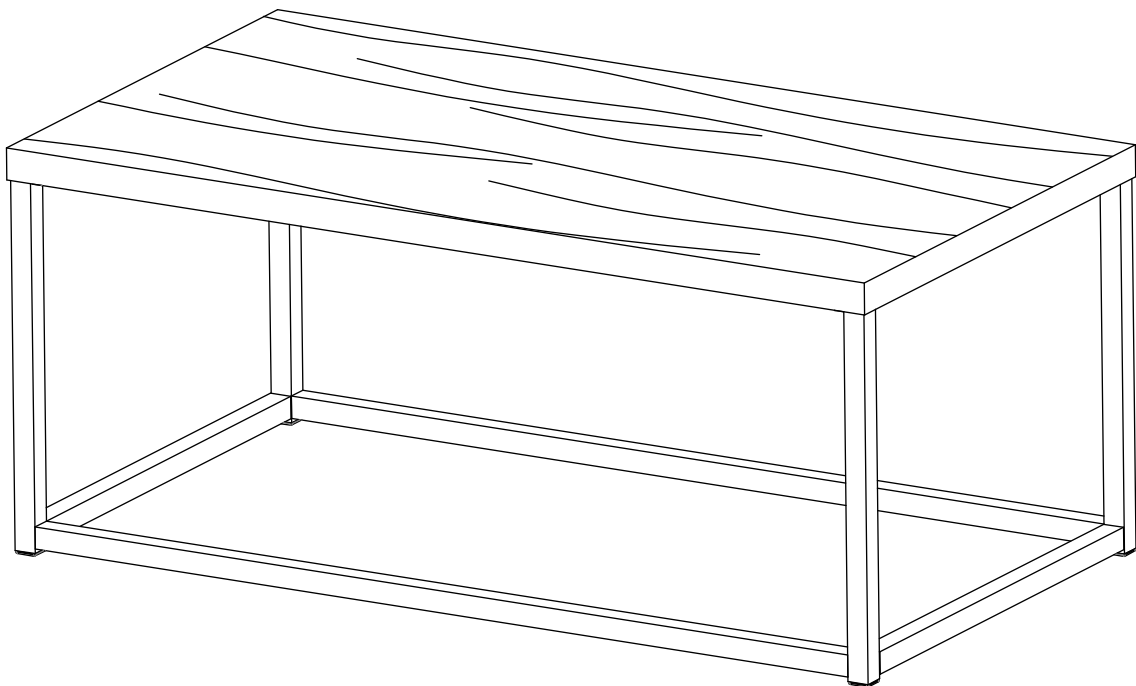

CK503000TX

GLYNN COCKTAIL

Parts List

Please review all parts and hardware before disposing of any packaging.

Call Customer Service if missing hardware.

Carefully study the diagrams below.

You may receive extra hardware with your unit.

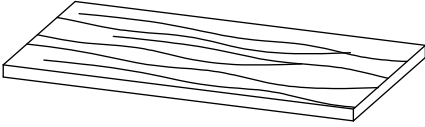
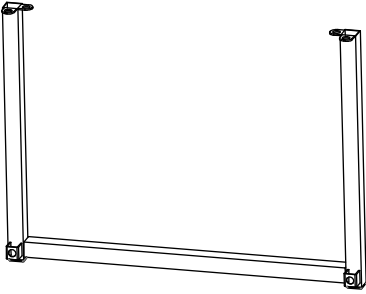
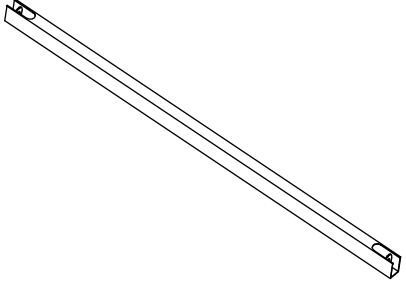
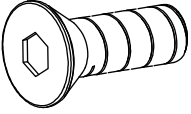
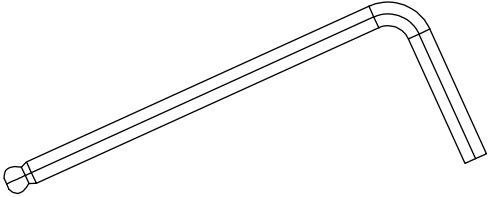
| | | |
|--|--|---|
| <p>1 1PC</p>  <p>Wood Top</p> | <p>2 2PCS</p>  <p>Side Panels</p> | <p>3 2PCS</p>  <p>Stretchers</p> |
| <p>A 12PCS</p>  <p>Bolts 1/4"x 5/8"</p> | <p>B 1PC</p>  <p>Wrench</p> | |

Care and Cleaning Instructions:

Before using, wipe with a clean, dry cloth.
 Avoid rubbing or scratching the surface with rough or abrasive objects.

For replacement parts or questions, please call customer service at 1-800-633-5096.

Assembly Tool Required
No.2 Phillips Screwdriver

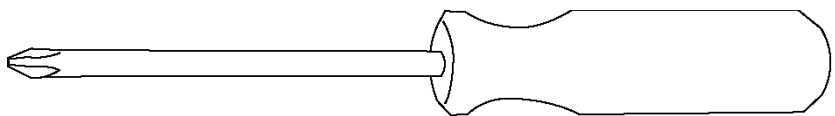

CK503000TX

GLYNN COCKTAIL

Assembly Instructions

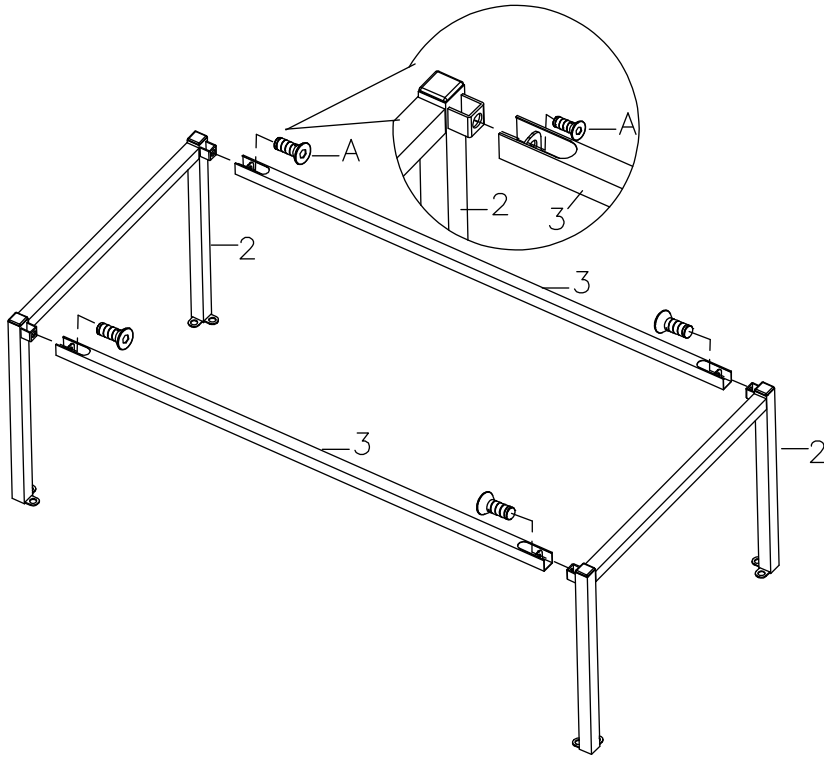

Figure 1

Step 1:

Unit assembly should begin with parts turned upside down for Step 1.

Attach Stretchers (3) to Side Panels (2) using Bolts (A) as shown.

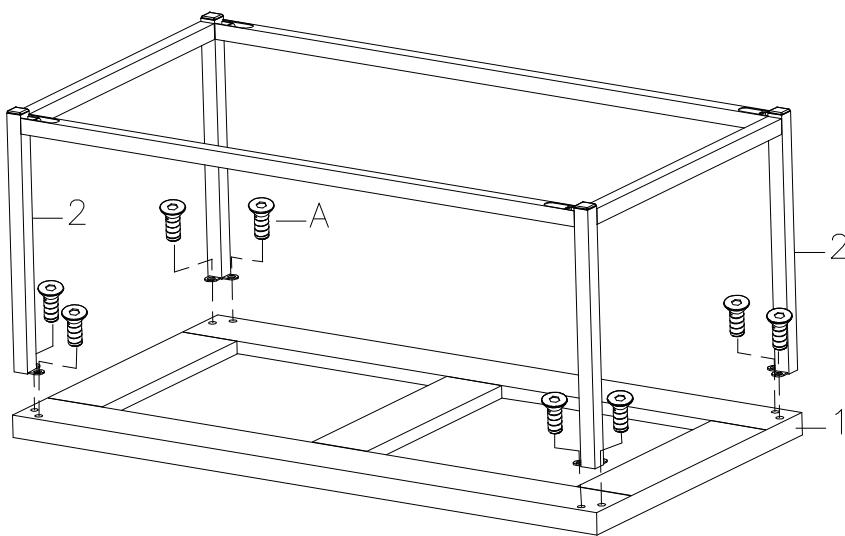

Figure 2

Step 2:

Attached the assembled unit to Wood Top (1) using Bolts (A) as shown.

Your Glynn Cocktail assembly is now complete.

Parts Replacement Form

Customer Information

Name _____

Address _____

City/State/Zip Code _____

Phone Number _____

Please indicate where you purchased this item: Store/Website/Catalog

Please indicate color/size/style number:

| Style No | Parts Letter | Parts Description | Quantity Needed |
|----------|--------------|-------------------|-----------------|
| _____ | _____ | _____ | _____ |
| _____ | _____ | _____ | _____ |
| _____ | _____ | _____ | _____ |

Please immediately examine this product carefully. Any request for missing parts or damage replacement must be received within 90 days of your receipt of the product. Replacement, if available, will be honored within this time frame. Parts will not be available for items arriving fully assembled. We do not recommend modifying product(s) and we are not responsible for any damages due to product modification(s). If damages or missing parts are not reported within 90 days of your receipt, we are under no obligation to provide parts or replacement merchandise.

Please contact Southern Enterprises at 800-633-5096 or in Dallas 972-869-0111/ 9am – 4pm Mon-Fri Central time if you have product issues or email us at service@seidal.com. Please ask for customer service representative for issues involving damages or replacement parts. Please ask for technical assistance representative for any issues with product and assembly/construction.

Please contact the retailer that you purchased from for returns.



Southern
ENTERPRISES

Customer Service 1-800-633-5096

service@seidal.com

Southern Enterprises, Inc.

600 Freeport Parkway, Suite 200

Coppell, Texas 75019