

**HZ636100TX**

**Maydell Single -Drawer  
Storage**

**Assembly Instructions**



**Southern**  
ENTERPRISES

For assistance with assembly, contact:  
Southern Enterprises Inc.  
Customer Service 1-800-633-5096  
[service@seidal.com](mailto:service@seidal.com)  
[www.seidal.com](http://www.seidal.com)

PO:13778

Support loading capacities



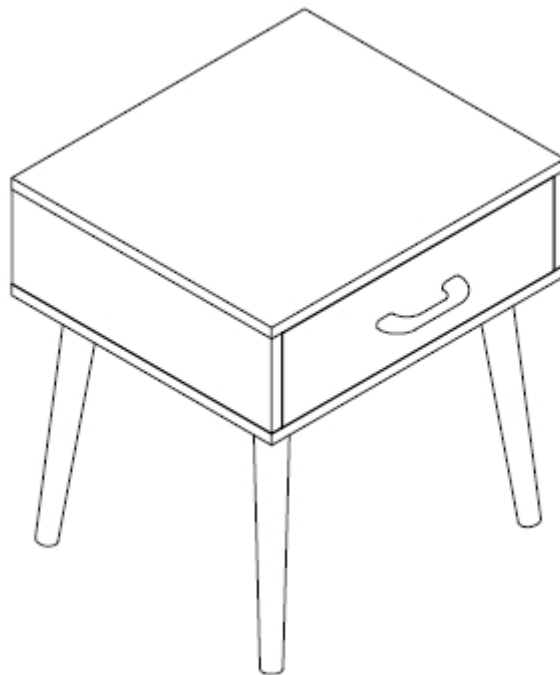



Top: max 25 lbs

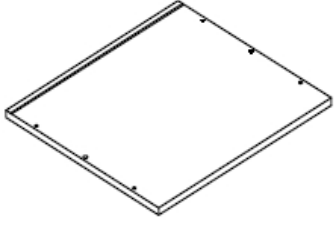
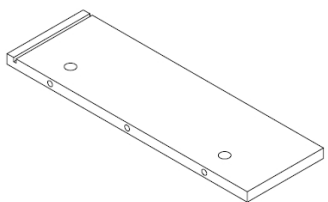
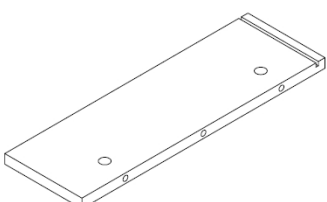
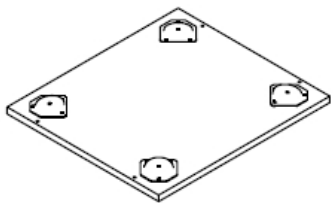
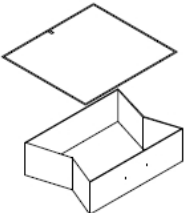

# HZ636100TX

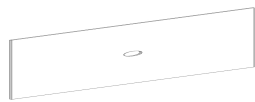
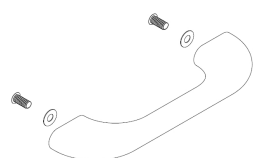
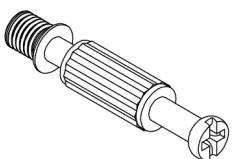
## Maydell Single-Drawer Storage Parts List

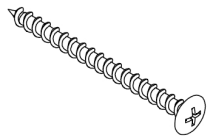
Please review all parts and hardware before disposing of any packaging. Before beginning assembly, separate each type of hardware. Carefully study the diagrams below and check that you have all parts indicated. Call Customer Service if missing hardware. Using the incorrect hardware will cause damage.

<p>A 1PC</p>  <p>Top Board</p>	<p>B 1PC</p>  <p>Right Side Board</p>	<p>C 1PC</p>  <p>Left Side Board</p>	<p>D 1PC</p>  <p>Bottom Board</p>
<p>E 1PC</p>  <p>Drawer Assembly</p>	<p>F 4PCS</p>  <p>Wood Legs</p>	<p>G 1PC</p>  <p>Back Board</p>	<p>H 1PC</p>  <p>Handle</p>
<p>1 4PCS</p>  <p>Cam Bolt</p>	<p>2 4PCS</p>  <p>Cam Lock</p>	<p>3 4PCS</p>  <p>Screw</p>	<p>4 4PCS</p>  <p>Wood Dowel</p>

### Care and Cleaning Instructions:

Before using, wipe with a clean, dry cloth. Avoid rubbing or scratching the surface with rough or abrasive objects.

For replacement parts or questions, please Call Customer Service at 1-800-633-5096.

### Assembly Tool Required

No.2 Phillips Screwdriver

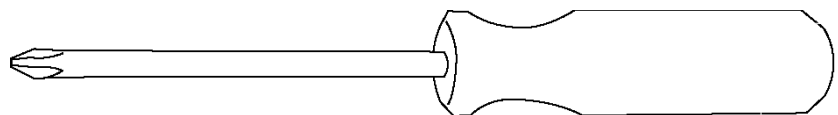

# HZ636100TX

## Maydell Single-Drawer Storage

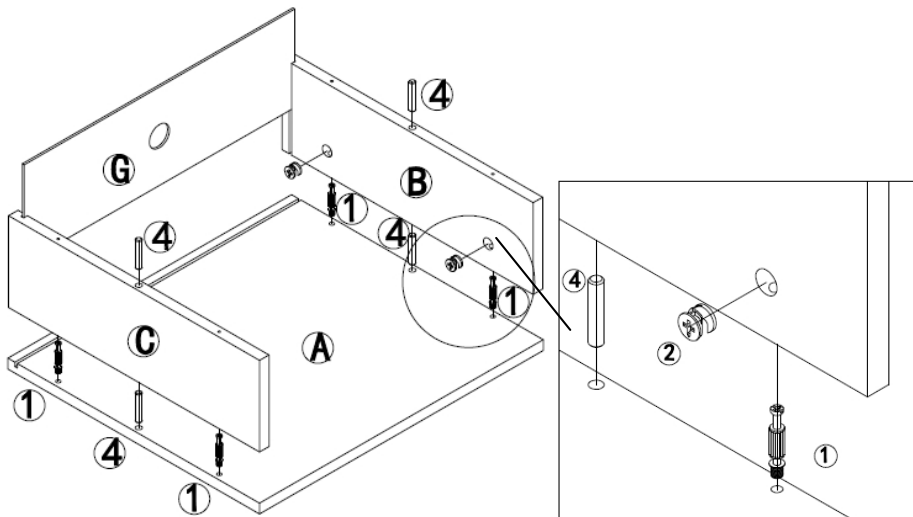

Figure 1

### Step 1:

Unit assembly should begin with parts turned upside down for Step 1

Screw Cam Bolts (1) into the threaded holes and insert Wood Dowels (4) into the hollow holes on Top Board (A).

Attach Right/Left Side Boards (B/C) onto Top Board (A) by inserting Wood Dowels and Cam Bolts into their corresponding holes until all panels meet. Insert Wood Dowels (4) into the top holes on Side Panels (B/C).

Insert Back Board (G) into the grooves on Right/Left Side Boards (B/C) and into the groove on Top Board (A).

Insert Cam Locks (2) into their corresponding holes and turn clockwise with a Phillips screwdriver to tighten.

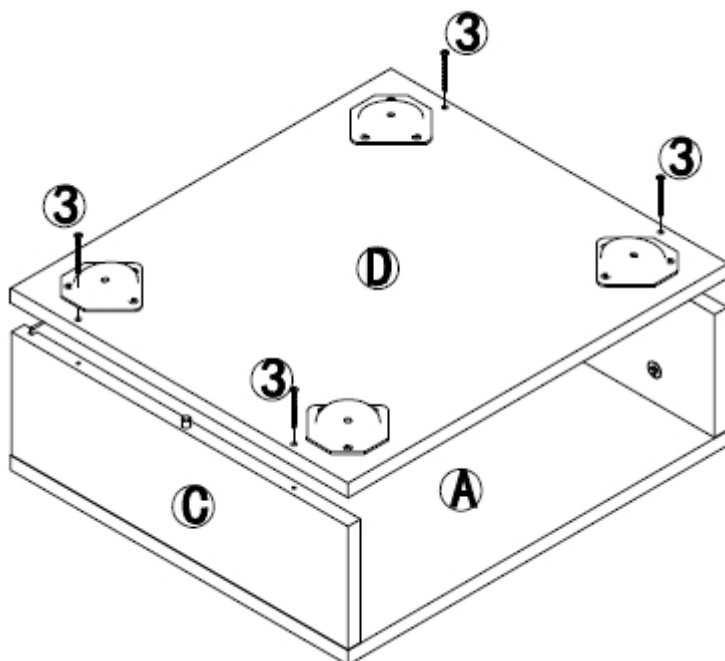
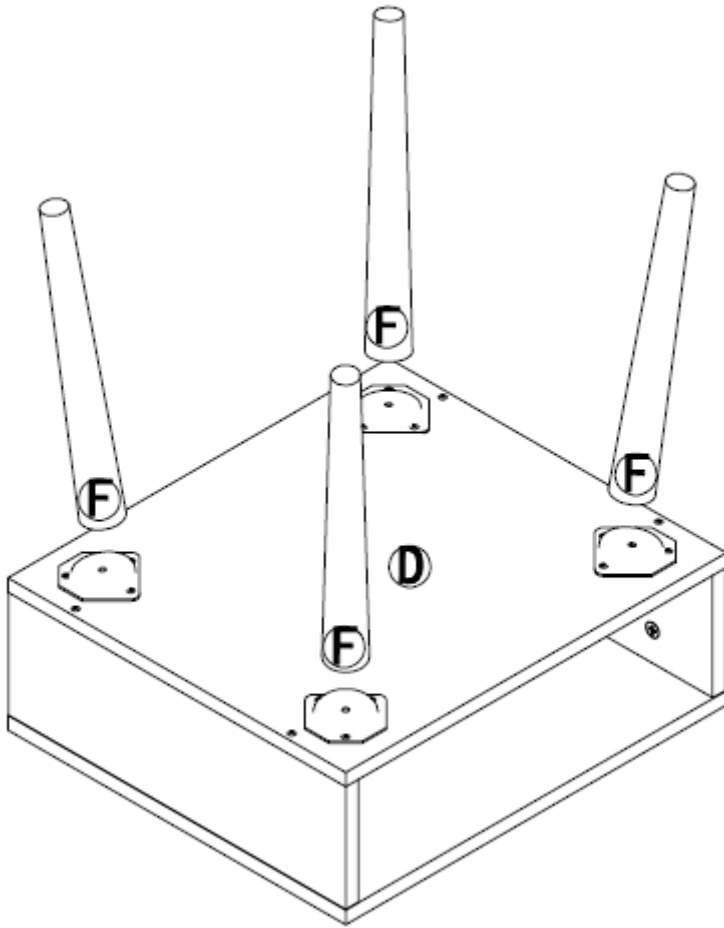

Figure 2

### Step 2:

Place Bottom Board (D) onto the assembled unit.

Insert Screws (3) into their corresponding holes and tighten with a Phillips screwdriver.

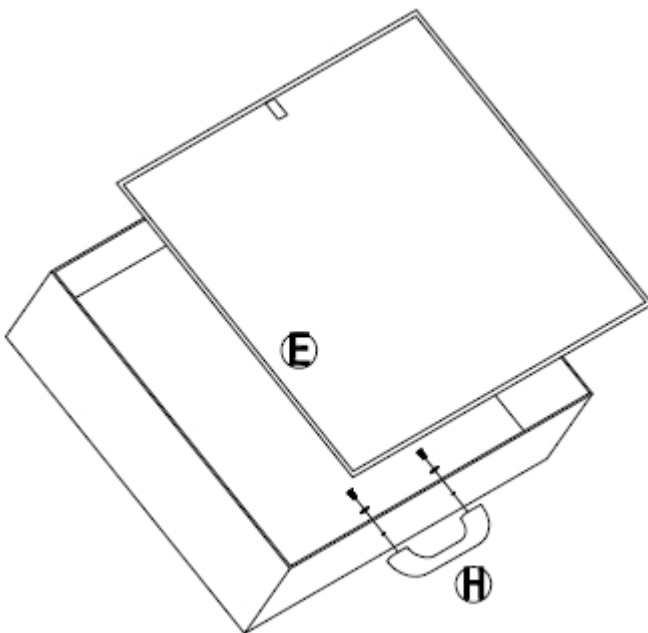

**Figure 3**

**Step 3:**

Attach Legs (**F**) onto the bottom board and turn clockwise by hand to tighten.

Turn the assembled unit upright.

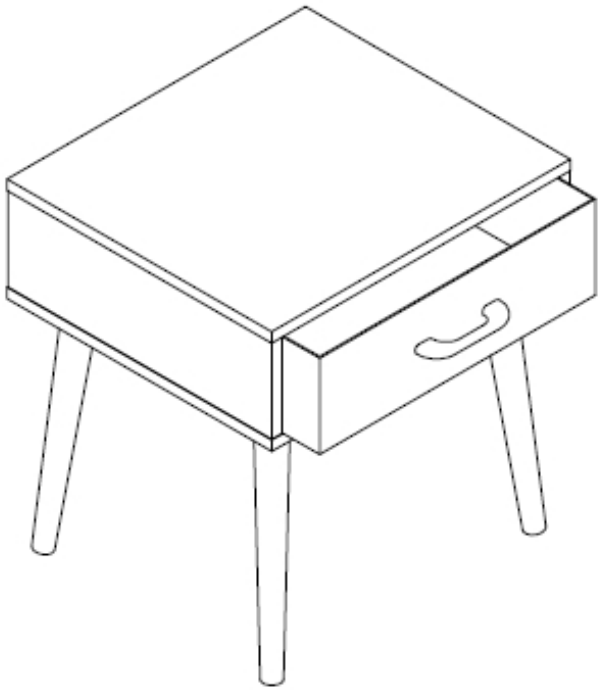

**Figure 4**

**Step 4:**

Attach Wood Handle (**H**) onto the drawer and use the supplied screws to secure.

Insert the drawer bottom (**E**) into the drawer.



**Figure5**

**Step 5:**

Put the drawer inside the shelf.

Now your unit is complete.



Customer Service 1-800-633-5096

[service@seidal.com](mailto:service@seidal.com)

Southern Enterprises, Inc.

600 Freeport Parkway, Suite 200

Coppell, Texas 75019

# Parts Replacement Form

## Customer Information

Name \_\_\_\_\_

Address \_\_\_\_\_

City/State/Zip Code \_\_\_\_\_

Phone Number \_\_\_\_\_

Please indicate where you purchased this item: Store/Website/Catalog

\_\_\_\_\_

Please indicate color/size/style number:

\_\_\_\_\_

Style No	Parts Letter	Parts Description	Quantity Needed
_____	_____	_____	_____
_____	_____	_____	_____
_____	_____	_____	_____

Please immediately examine this product carefully. Any request for missing parts or damage replacement must be received within 90 days of your receipt of the product. Replacement, if available, will be honored within this time frame. Parts will not be available for items arriving fully assembled. We do not recommend modifying product(s) and we are not responsible for any damages due to product modification(s). If damages or missing parts are not reported within 90 days of your receipt, we are under no obligation to provide parts or replacement merchandise.

Please contact Southern Enterprises at 800-633-5096 or in Dallas 972-869-0111/ 9am – 4pm Mon-Fri Central time if you have product issues or email us at [service@seidal.com](mailto:service@seidal.com). Please ask for customer service representative for issues involving damages or replacement parts. Please ask for technical assistance representative for any issues with product and assembly/construction.

Please contact the retailer that you purchased from for returns.

Customer Service 1-800-633-5096  
[service@seidal.com](mailto:service@seidal.com)  
Southern Enterprises, Inc.  
600 Freeport Parkway, Suite 200  
Coppell, Texas 75019

