

HZ030300TX

Kismet Multi-Finish Cabinet

Assembly Instructions



Southern
ENTERPRISES

For assistance with assembly, contact:
Southern Enterprises, Inc.
Customer Service: 1-800-633-5096
service@seidal.com
www.seifurniturestore.com

PO#:

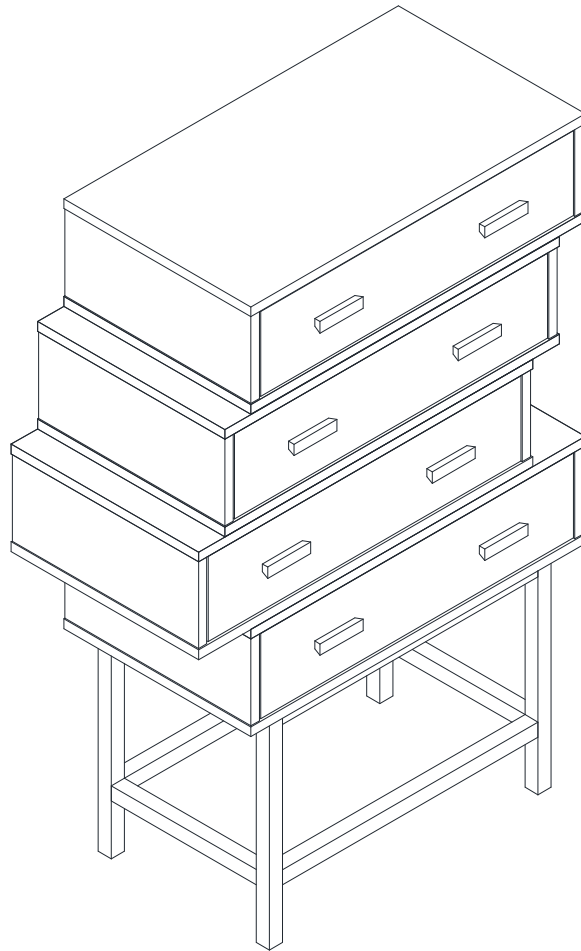







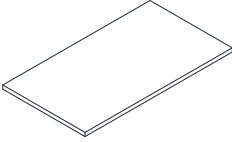
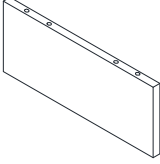
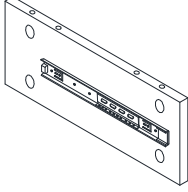
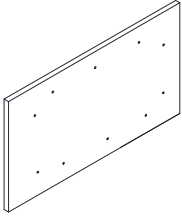
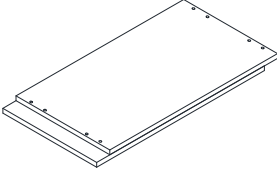
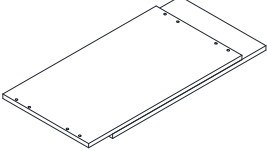
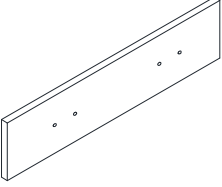
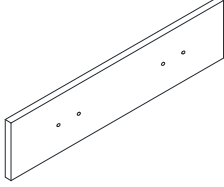
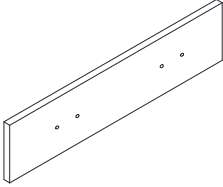
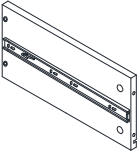
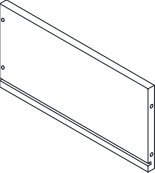
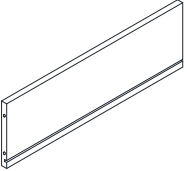

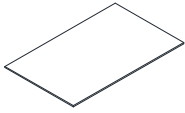
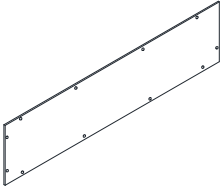
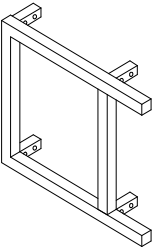
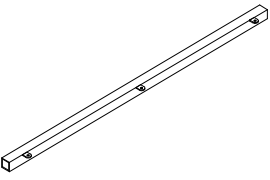
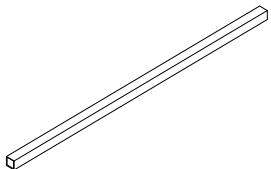

Kismet Multifinish Cabinet

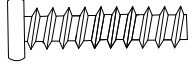
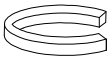
Parts List

Please check packaging for all parts and hardware before discarding. Unpack and lay parts on clean, padded surface like carpet or a blanket. Check that you have all parts indicated. Call customer service if any hardware is missing. Before beginning assembly, carefully study the diagrams below and sort your hardware according to the pictures. Using the incorrect hardware will cause damage.

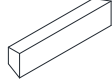
1)  Quantity of 1 Top Panel	2)  Quantity of 4 Left Side Panel	3)  Quantity of 4 Right Side Panel
4)  Quantity of 1 Bottom Panel	5)  Quantity of 2 Upper Shelf Panel	6)  Quantity of 1 Lower Shelf Panel
7)  Quantity of 2 Drawer Front Panel-1	8)  Quantity of 1 Drawer Front Panel-2	9)  Quantity of 1 Drawer Front Panel-3
10)  Quantity of 4 Drawer Left Side Panel	11)  Quantity of 4 Drawer Right Side Panel	12)  Quantity of 4 Drawer Back Panel

<p>13) Quantity of 4</p>  <p>Drawer Bottom Panel</p>	<p>14) Quantity of 4</p>  <p>Back Panel</p>	<p>15) Quantity of 2</p>  <p>Metal Frame</p>
<p>16) Quantity of 2</p>  <p>Top Stretcher</p>	<p>17) Quantity of 2</p>  <p>Bottom Stretcher</p>	
<p>A) Quantity of 32</p>  <p>Cam Bolts</p>	<p>B) Quantity of 32</p>  <p>Cam Locks</p>	<p>C) Quantity of 32</p>  <p>Wood Dowels Dia. 5/16"x1-1/4"</p>
<p>D) Quantity of 16</p>  <p>Bolt Dia. 1/4x3/4" L</p>	<p>E) Quantity of 16</p>  <p>Spring Washer Dia. 1/4"</p>	<p>F) Quantity of 16</p>  <p>Flat washer Dia. 1/4" x 3/4"</p>
<p>G) Quantity of 1</p>  <p>Allen Wrench</p>	<p>H) Quantity of 58</p>  <p>Screw Dia. 1/8" x 1/2" L</p>	<p>I) Quantity of 8</p>  <p>Knob</p>

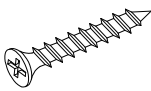
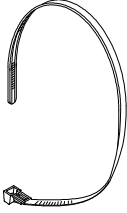
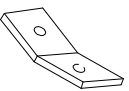
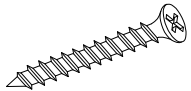
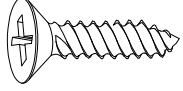
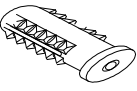
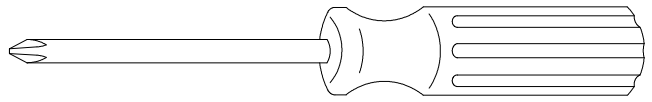
<p>J)</p> <p>Quantity of 16</p>  <p>Bolts Dia. 5/32" x 1" L</p>	<p>K)</p> <p>Quantity of 32</p>  <p>Screw Dia. 5/32" x 1L</p>	<p>L)</p> <p>Quantity of 2</p>  <p>Plastic Strap</p>
<p>M)</p> <p>Quantity of 4</p>  <p>Bracket</p>	<p>N)</p> <p>Quantity of 2</p>  <p>Screws Dia. 1/8"x1-1/2"L</p>	<p>O)</p> <p>Quantity of 2</p>  <p>Screws Dia. 1/8"x5/8"L</p>
<p>P)</p> <p>Quantity of 2</p>  <p>Anchor</p>		
<p>Care and Cleaning Instructions: Before using, wipe with a clean, dry cloth. Avoid rubbing or scratching the surface with rough or abrasive objects.</p>		<p>For replacement parts or questions, please call SEI Customer Service at 1-800-633-5096.</p>
<p>Assembly Tool Required: No.2 Phillips Screwdriver, Hammer (Not Included)</p>		

Kismet Multifinish Cabinet

Assembly Instructions

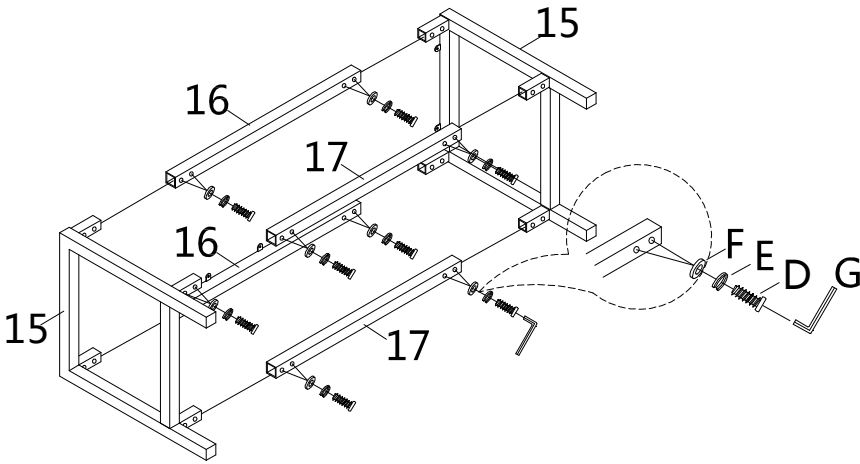

Figure 1

Align Bolts **(D)** by hand.

Attach the Metal Frames **(15)** to Top Stretchers **(16)** and Bottom Stretchers **(17)** with Bolts **(D)**, Spring Washers **(E)**, and Flat Washers **(F)**.

Tighten Bolts **(D)** with Allen Wrench **(G)**.

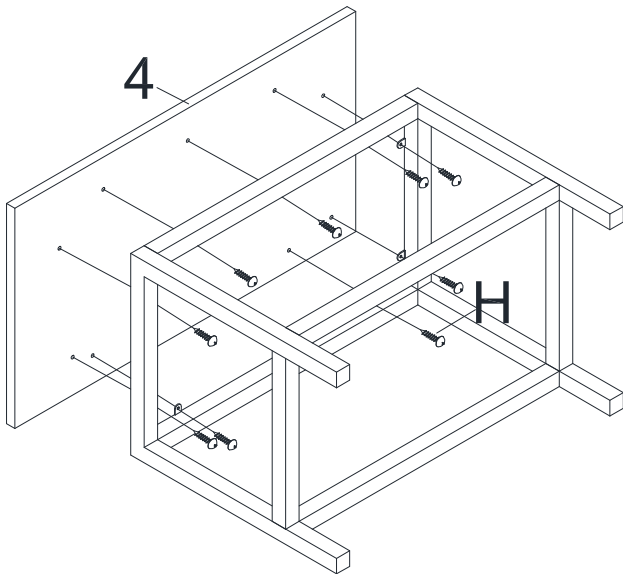
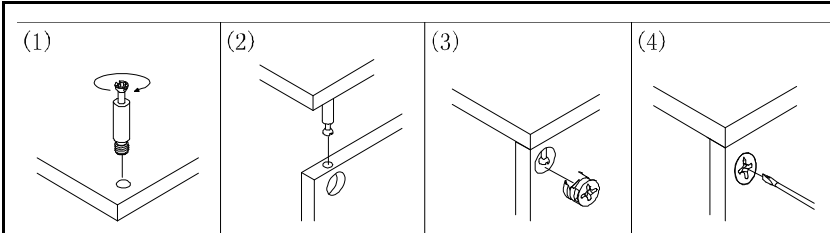

Figure 2

Attach the assembled unit from Figure 1 to the Bottom Panel **(4)** with Screws **(H)**.

Tighten Screws **(H)** with Phillips screwdriver (not included).



Please do not overtighten cam locks. Stop when they feel secure.

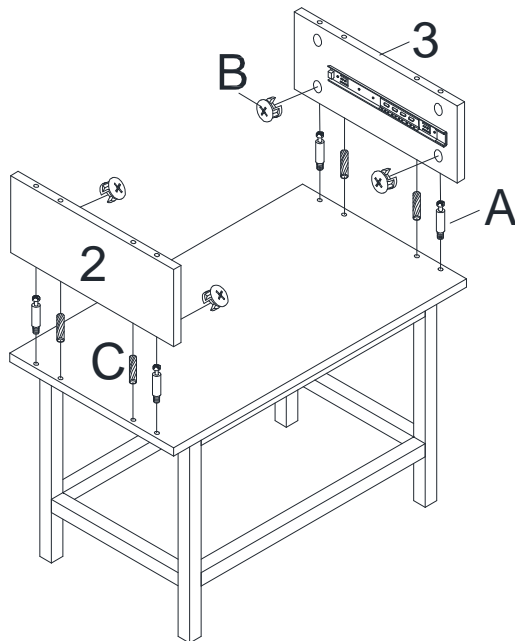

Figure 3

Align Cam Bolts **(A)** by hand.

Insert Cam Locks **(B)** into corresponding holes on Side Panels **(2/3)**.

Screw Cam Bolts **(A)** into threaded holes on Bottom Panel **(4)**.

Attach Side Panels **(2/3)** to Bottom Panel **(4)** by inserting Cam Bolts **(A)** and Wood Dowels **(C)** into corresponding holes until all panels meet.

Tighten Cam Bolts **(A)** by rotating Cam Locks **(B)** clockwise using Phillips screwdriver (not included).

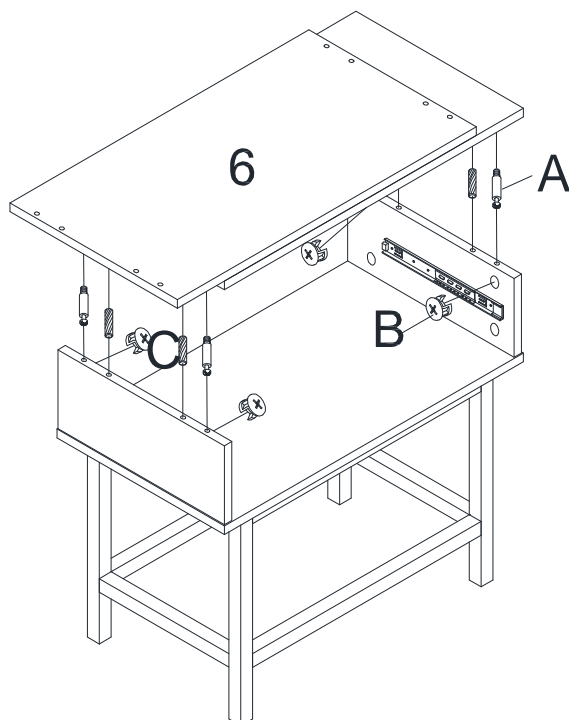

Figure 4

Align Cam Bolts **(A)** by hand.

Insert Cam Locks **(B)** into corresponding holes on Side Panels **(2/3)**.

Screw Cam Bolts **(A)** into threaded holes on Lower Shelf Panel **(6)**.

Attach Lower Shelf Panel **(6)** to Side Panels **(2/3)** by inserting Cam Bolts **(A)** and Wood Dowels **(C)** into corresponding holes until all panels meet.

Tighten Cam Bolts **(A)** by rotating Cam Locks **(B)** clockwise using Phillips screwdriver (not included).

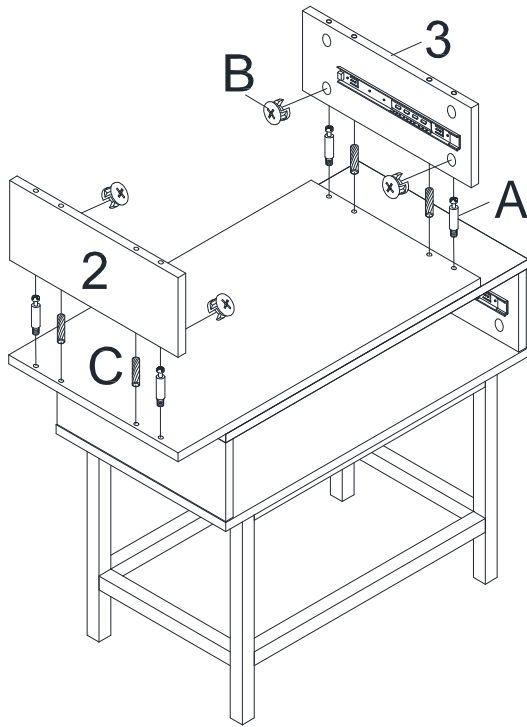

Figure 5

Align Cam Bolts **(A)** by hand.

Insert Cam Locks **(B)** into corresponding holes on Side Panels **(2/3)**.

Screw Cam Bolts **(A)** into threaded holes on Lower Shelf Panel **(6)**.

Attach Side Panels **(2/3)** to Lower Shelf Panel **(6)** by inserting Cam Bolts **(A)** and Wood Dowels **(C)** into corresponding holes until all panels meet.

Tighten Cam Bolts **(A)** by rotating Cam Locks **(B)** clockwise using Phillips screwdriver (not included).

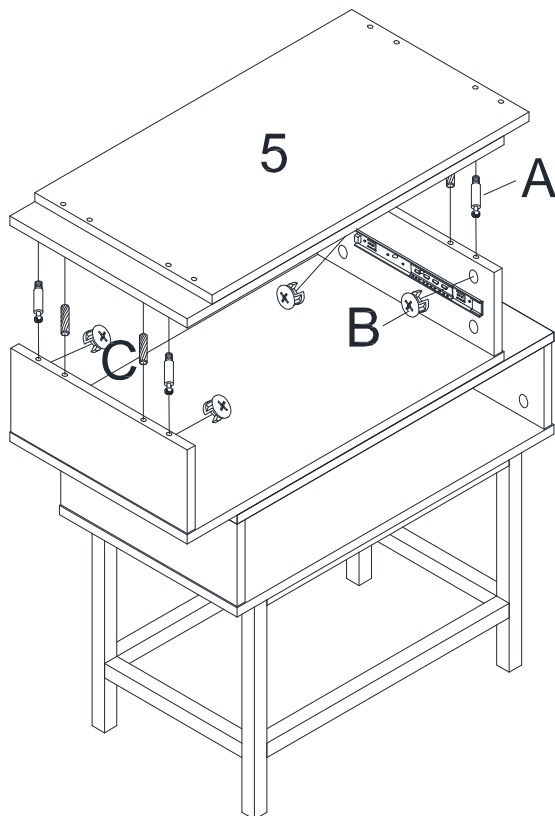

Figure 6

Align Cam Bolts **(A)** by hand.

Insert Cam Locks **(B)** into corresponding holes on Side Panels **(2/3)**.

Screw Cam Bolts **(A)** into threaded holes on Upper Shelf Panel **(5)**.

Attach Upper Shelf Panel **(5)** to Side Panels **(2/3)** by inserting Cam Bolts **(A)** and Wood Dowels **(C)** into corresponding holes until all panels meet.

Tighten Cam Bolts **(A)** by rotating Cam Locks **(B)** clockwise using Phillips screwdriver (not included).

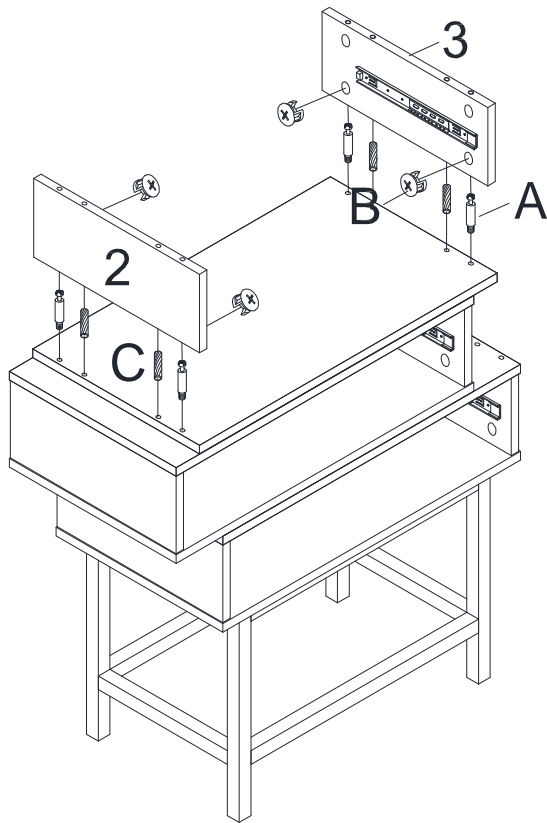

Figure 7

Align Cam Bolts **(A)** by hand.

Insert Cam Locks **(B)** into corresponding holes on Side Panels **(2/3)**.

Screw Cam Bolts **(A)** into threaded holes on Upper Shelf Panel **(5)**.

Attach Side Panels **(2/3)** to Upper Shelf Panel **(5)** by inserting Cam Bolts **(A)** and Wood Dowels **(C)** into corresponding holes until all panels meet.

Tighten Cam Bolts **(A)** by rotating Cam Locks **(B)** clockwise using Phillips screwdriver (not include).

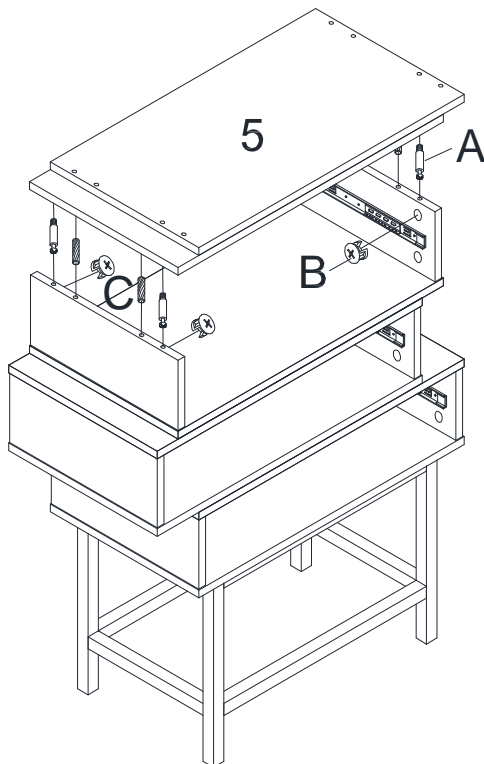

Figure 8

Align Cam Bolts **(A)** by hand.

Insert Cam Locks **(B)** into corresponding holes on Side Panels **(2/3)**.

Screw Cam Bolts **(A)** into threaded holes on Shelf Panel **(5)**.

Attach Shelf Panel **(5)** to Side Panels **(2/3)** by inserting Cam Bolts **(A)** and Wood Dowels **(C)** into corresponding holes until all panels meet.

Tighten Cam Bolts **(A)** by rotating Cam Locks **(B)** clockwise using Phillips screwdriver (not included).

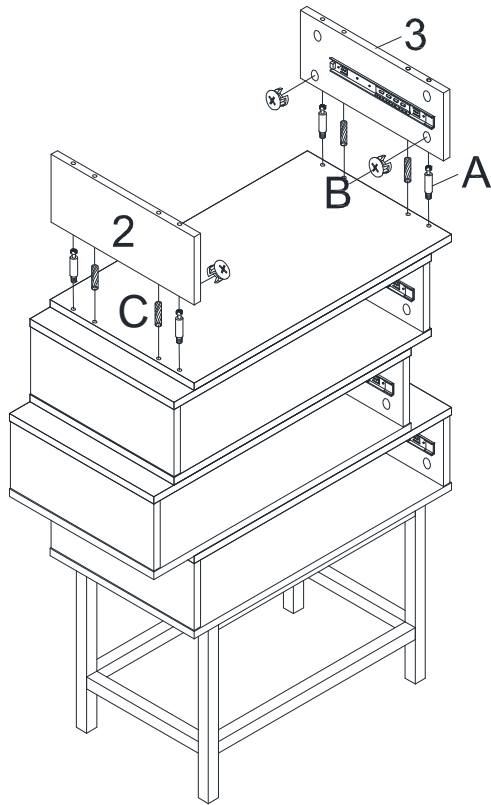

Figure 9

Align Cam Bolts **(A)** by hand.

Insert Cam Locks **(B)** into corresponding holes on Side Panels **(2/3)**.

Screw Cam Bolts **(A)** into threaded holes on Shelf Panel **(5)**.

Attach Side Panels **(2/3)** to Shelf Panel **(5)** by inserting Cam Bolts **(A)** and Wood Dowels **(C)** into corresponding holes until all panels meet.

Tighten Cam Bolts **(A)** by rotating Cam Locks **(B)** clockwise using Phillips screwdriver (not included).

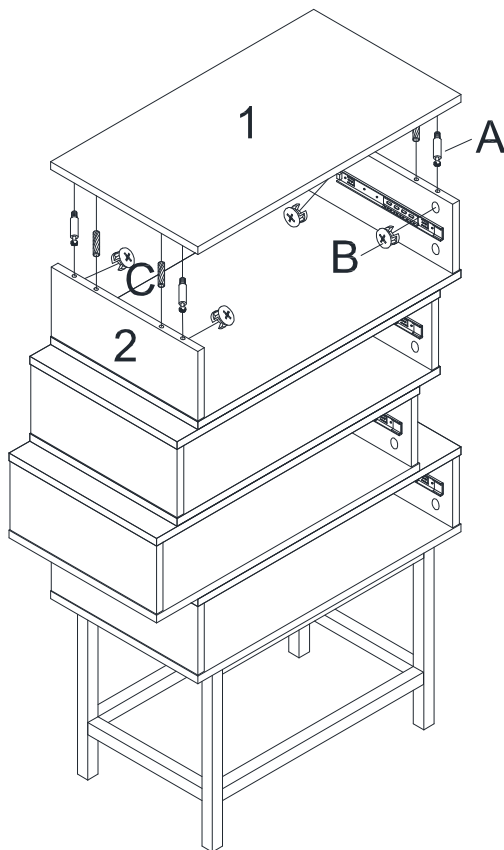

Figure 10

Align Cam Bolts **(A)** by hand.

Insert Cam Locks **(B)** into corresponding holes on Side Panels **(2/3)**.

Screw Cam Bolts **(A)** into threaded holes on Top Panel **(1)**.

Attach Top Panel **(1)** to Side Panels **(2/3)** by inserting Cam Bolts **(A)** and Wood Dowels **(C)** into corresponding holes until all panels meet.

Tighten Cam Bolts **(A)** by rotating Cam Locks **(B)** clockwise using Phillips screwdriver (not included).

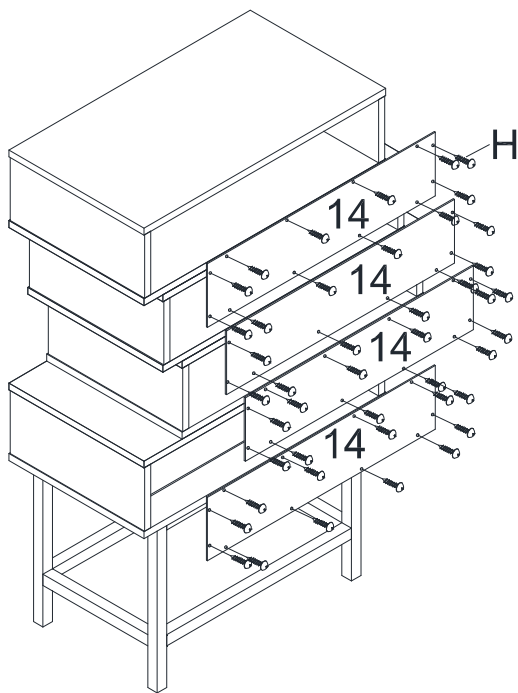

Figure 11

Attach Back Panels (**14**) to back of the unit with Screws (**H**).

Tighten Screws (**H**) with Phillips screwdriver (not included).

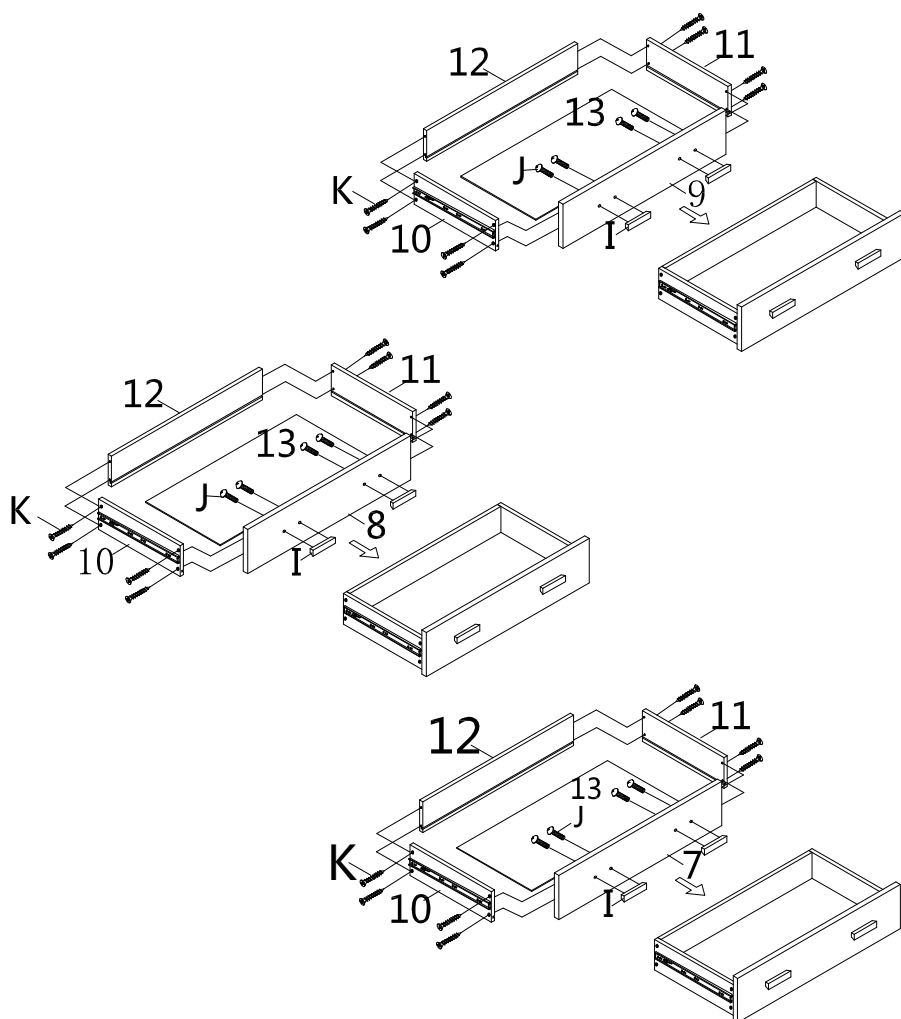

Figure 12

Align Screws (**K**) by hand.

Attach Drawer Side Panels (**10/11**) to Drawer Back Panels (**12**) using Screws (**K**).

Tighten Screws (**K**) with Phillips screwdriver (not included).

Insert Drawer Bottom Panels (**13**) into the grooves of Drawer Side Panels (**10/11/12**).

Attach Drawer Front Panels (**7/8/9**) to the assembled units using Screws (**K**).

Finally, attach Knobs (**I**) to the Drawer Front Panels (**7/8/9**) using Bolts (**I**).

Tighten Bolts (**I**) with Phillips screwdriver (not included).

Repeat step for additional drawers using Drawer Front Panels (**7/8/9**).

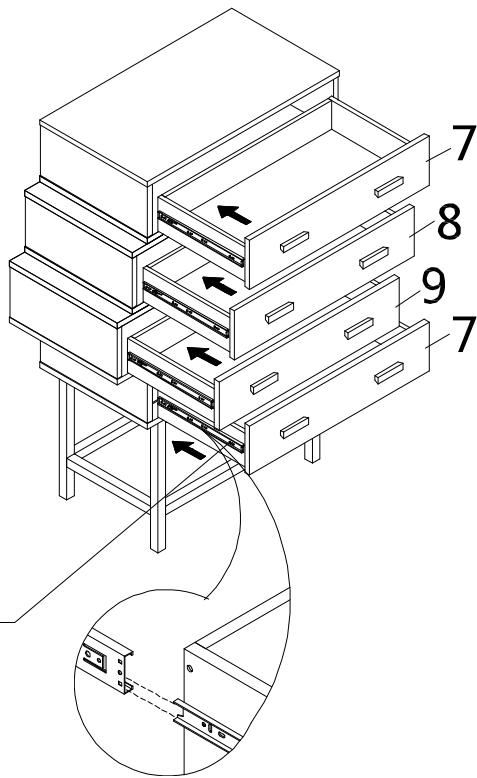

If drawer does not glide smoothly, adjust male slide to lower/raise height of drawer.

Insert drawers into assembled unit.

Make sure drawers glide smoothly in and out.

Note: There is a lever located on male slide for bottom drawer slide. Push lever to either side in order to detach male slide from female slide.

Figure 13

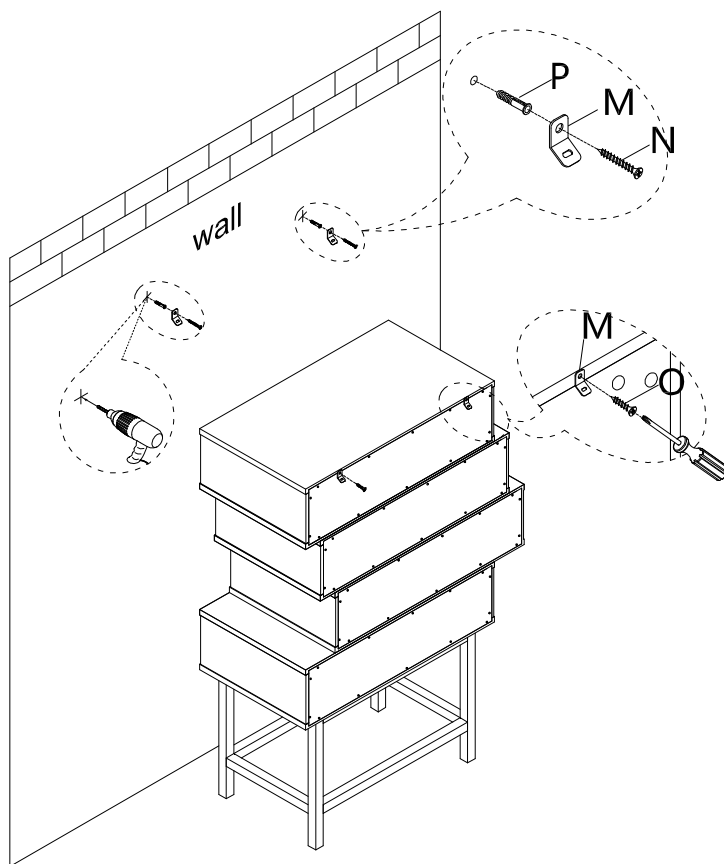

Attach Brackets (**M**) to Back Panel using Screws (**O**). Tighten Screws (**O**) using a Philips screwdriver (not included).

Mark two desired locations on wall.

Drill two 3/16" holes.

Insert Plastic Anchors (**P**) into the 2 holes, tap lightly with hammer (not included) as needed

Attach Brackets (**M**) to wall using Screws (**N**).

Tighten Screws (**N**) using a Philips screw driver (not included).

Figure 14

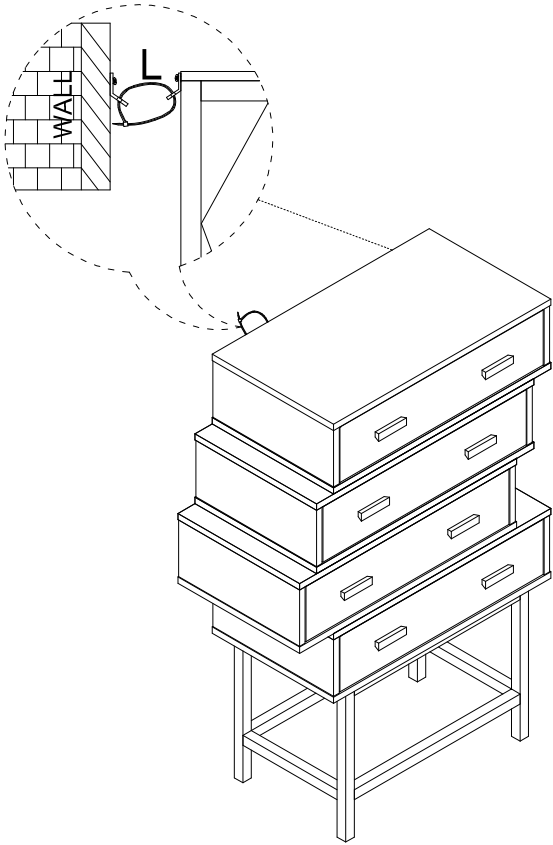

Figure 15

Move the Sideboard close to the wall.

Tie Brackets **(M)** together with Plastic Straps **(L)**.

Warning: Anti-tipping hardware must be used for this product to avoid tipping and injury.

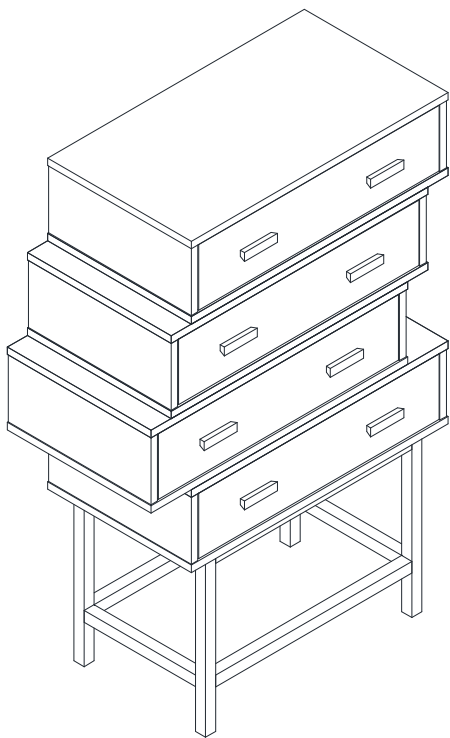

Figure 16

Now your Kismet Multi-Finish Cabinet is ready to use!

Parts Replacement Form

Customer Information

Name _____

Address _____

City/State/Zip Code _____

Phone Number _____

Please indicate where you purchased this item: Store/Website/Catalog

Please indicate color/size/style number:

Style No	Parts Letter	Parts Description	Quantity Needed
_____	_____	_____	_____
_____	_____	_____	_____
_____	_____	_____	_____

Please immediately examine this product carefully. Any request for missing parts or damage replacement must be received within 90 days of your receipt of the product. Replacement, if available, will be honored within this time frame. Parts will not be available for items arriving fully assembled. We do not recommend modifying product(s) and we are not responsible for any damages due to product modification(s). If damages or missing parts are not reported within 90 days of your receipt, we are under no obligation to provide parts or replacement merchandise.

For product issues, please contact Southern Enterprises at 800-633-5096 (toll-free) / 972-869-0111 (Dallas), Mon-Fri 9am – 4pm CST, or email us at service@seidal.com. Please ask for customer service representative for issues involving damages or replacement parts. Please ask for technical assistance representative for any issues with product and assembly/construction.

Please contact the retailer that you purchased from for returns.



Southern
ENTERPRISES

Customer Service: 1-800-633-5096
service@seidal.com

Southern Enterprises, Inc.
600 Freeport Parkway, Suite 200
Coppell, Texas 75019