

CK494300TX  
Cheswick Console  
Assembly Instructions



**Southern**  
ENTERPRISES

For assistance with assembly, contact:  
Southern Enterprises, Inc.  
Customer Service: 1-800-633-5096  
service@seidal.com  
[www.seidal.com](http://www.seidal.com)

**PO: 13865**



# Cheswick Console

## Parts List

Please check packaging for all parts and hardware before discarding. Unpack and lay parts on clean, padded surface like carpet or blanket. Check that you have all parts indicated. Call customer service if hardware is missing. Before beginning assembly, carefully study the diagrams below and sort your hardware according to the pictures. Using the incorrect hardware will cause damage.

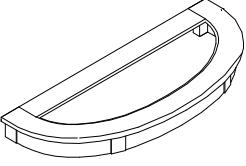
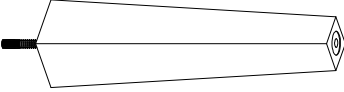
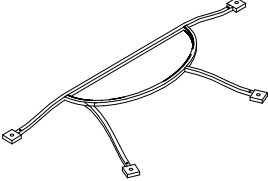
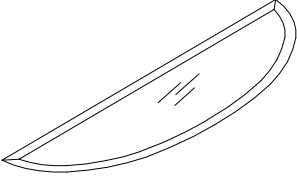
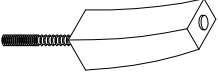
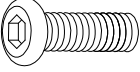
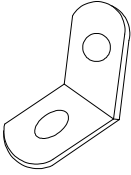
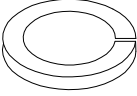
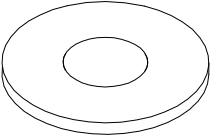
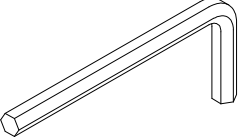
<p><b>A.</b> Quantity of 1</p>  <p>Top Panel</p>	<p><b>B.</b> Quantity of 4</p>  <p>Leg</p>	<p><b>C.</b> Quantity of 1</p>  <p>Bottom Frame</p>	<p><b>D.</b> Quantity of 1</p>  <p>Glass</p>
<p><b>E.</b> Quantity of 4</p>  <p>Feet</p>	<p><b>1</b> Quantity of 8</p>  <p>Bolt <math>\varnothing 1/4" \times 1/2" L</math></p>	<p><b>2</b> Quantity of 4</p>  <p>L Bracket</p>	<p><b>3</b> Quantity of 8</p>  <p>Spring Washer</p>
<p><b>4</b> Quantity of 8</p>  <p>Flat Washer</p>	<p><b>5</b> Quantity of 1</p>  <p>Allen Wrench</p>		

**Care and Cleaning Instructions:**

Before using, wipe with a clean, dry cloth.  
 Periodically apply furniture wax to renew the finish.  
 Avoid rubbing or scratching the surface with rough or abrasive objects.

For replacement parts or questions, please call customer service at 1-800-633-5096.

# Cheswick Console Assembly Instructions

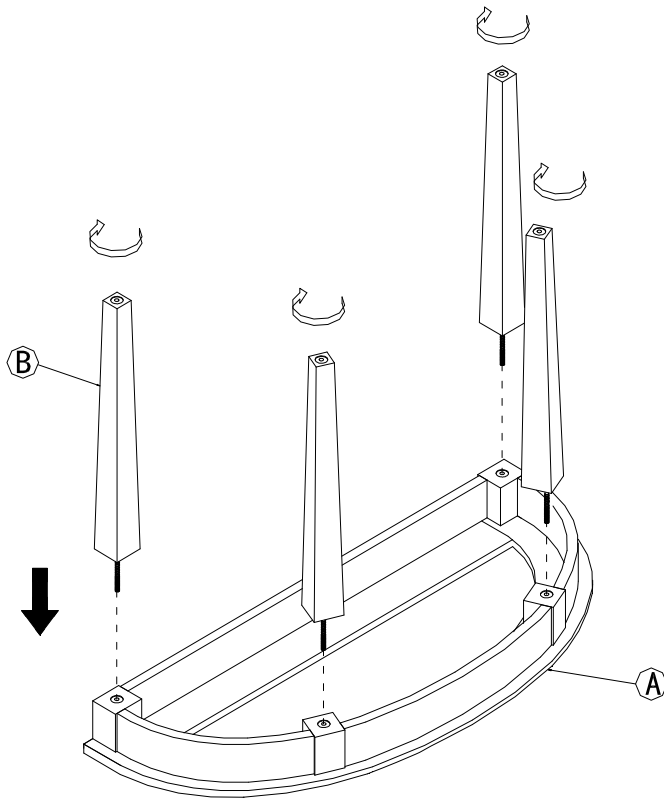

Attach Leg **(B)** into Top Panel **(A)** by hand as shown.

Figure 1

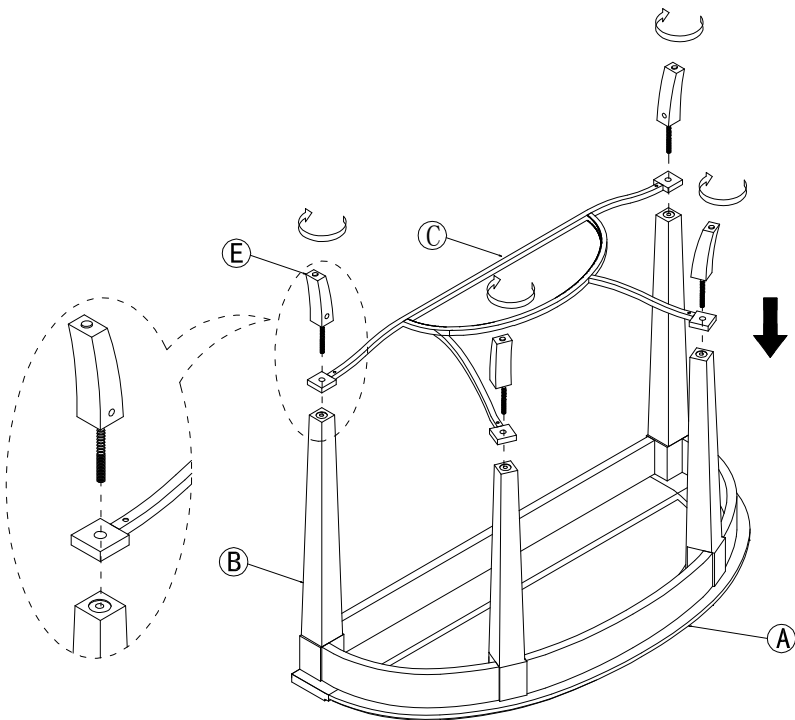

Attach Bottom Frame **(C)** with Leg **(B)**, secure with Feet **(E)** by hand as shown.

Figure 2

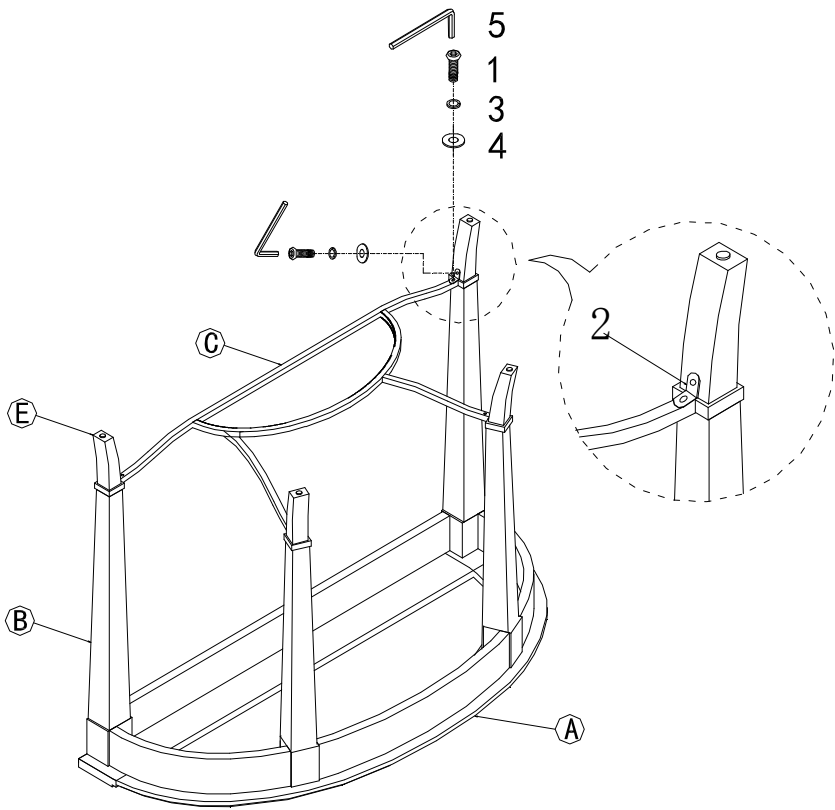

**Figure 3**

Secure the Bottom Frame (**C**) with Feet (**E**) using L Bracket (**2**), Bolt (**1**), Spring Washer (**3**) and Flat Washer (**4**).

Tighten bolt with Allen Wrench (**5**)

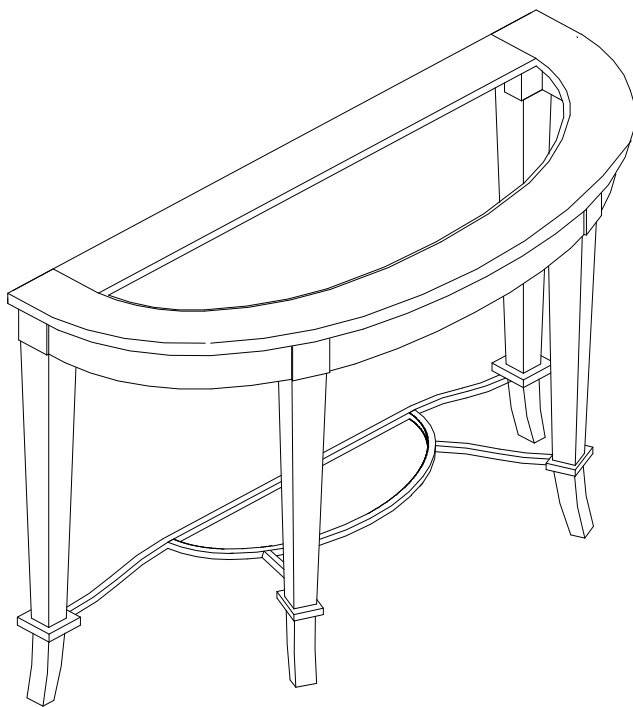

**Figure 4**

Turn the assembled unit over.

Place the Glass (D) into Top Panel (A).

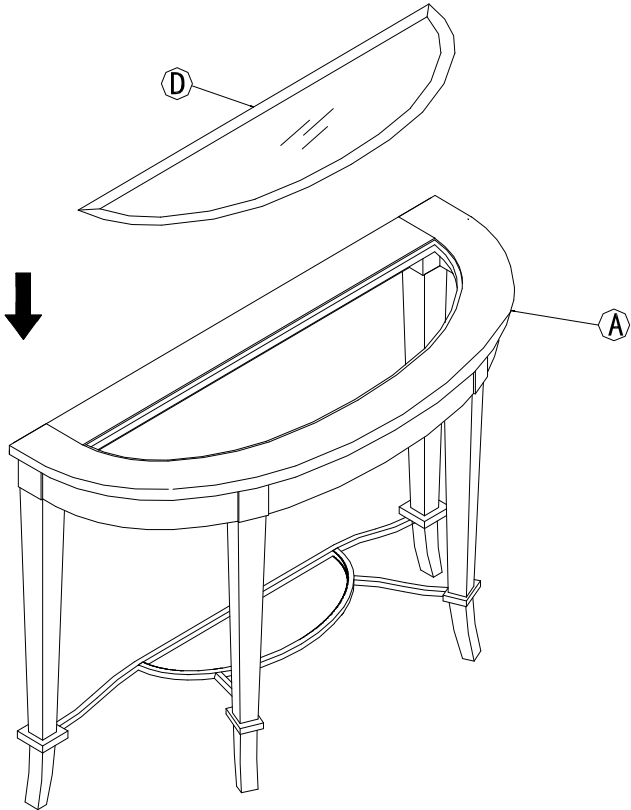

Figure 5

Now the console is ready to use.



Figure 6

# Parts Replacement Form

## Customer Information

Name \_\_\_\_\_

Address \_\_\_\_\_

City/State/Zip Code \_\_\_\_\_

Phone Number \_\_\_\_\_

Please indicate where you purchased this item: Store/Website/Catalog

\_\_\_\_\_

Please indicate color/size/style number:

\_\_\_\_\_

Style No	Parts Letter	Parts Description	Quantity Needed
----------	--------------	-------------------	-----------------

_____	_____	_____	_____
-------	-------	-------	-------

_____	_____	_____	_____
-------	-------	-------	-------

_____	_____	_____	_____
-------	-------	-------	-------

Please immediately examine this product carefully. Any request for missing parts or damage replacement must be received within 90 days of your receipt of the product. Replacement, if available, will be honored within this time frame. Parts will not be available for items arriving fully assembled. We do not recommend modifying product(s) and we are not responsible for any damages due to product modification(s). If damages or missing parts are not reported within 90 days of your receipt, we are under no obligation to provide parts or replacement merchandise.

For product issues, please contact Southern Enterprises at 800-633-5096 (toll-free) / 972-869-0111 (Dallas), Mon-Fri 9am – 4pm CST, or email us at [service@seidal.com](mailto:service@seidal.com). Please ask for customer service representative for issues involving damages or replacement parts. Please ask for technical assistance representative for any issues with product and assembly/construction.

Please contact the retailer that you purchased from for returns.



**Southern**  
ENTERPRISES

Customer Service: 1-800-633-5096  
[service@seidal.com](mailto:service@seidal.com)

Southern Enterprises, Inc.  
600 Freeport Parkway, Suite 200  
Coppell, Texas 75019