

CM501400TX  
Morgana Console  
Assembly Instructions

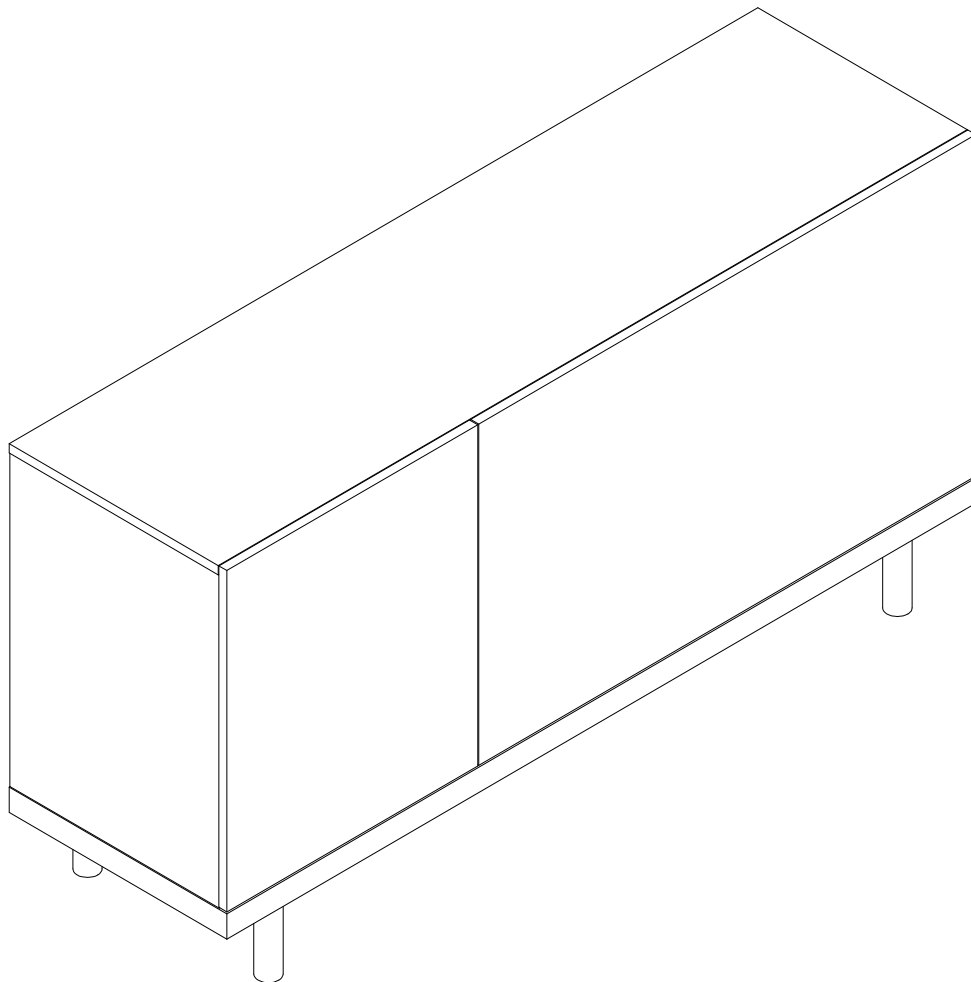

Southern  
ENTERPRISES











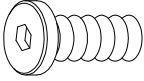
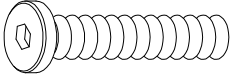
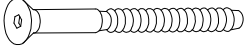

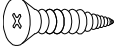

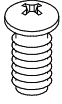
For assistance with assembly contact:  
Southern Enterprises Inc.  
Customer Service 1-800-633-5096  
[service@seidal.com](mailto:service@seidal.com)  
[www.seifurniturestore.com](http://www.seifurniturestore.com)



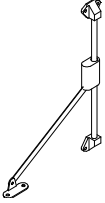
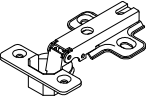
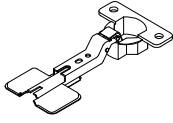
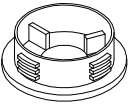
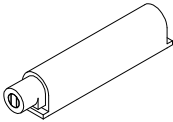
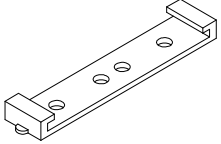

# CM501400TX Morgana Console

## Parts List

Please check packaging for all parts and hardware before discarding. Unpack and lay parts on clean, padded surface like carpet or a blanket. Check that you have all the parts indicated. Call customer service if any hardware is missing. Before beginning assembly, carefully study the diagrams below and sort your hardware according to the pictures. Using the incorrect hardware will cause damage.

<p><b>A.</b> Quantity of 4</p>  <p>Bolt 1/4x3/4"L</p>	<p><b>B.</b> Quantity of 6</p>  <p>Bolt 1/4x2-1/4"L</p>	<p><b>C.</b> Quantity of 8</p>  <p>Bolt 1/4"x2-3/4"L</p>
<p><b>D.</b> Quantity of 1</p>  <p>Allen wrench</p>	<p><b>E.</b> Quantity of 22</p>  <p>Screw <math>\Phi</math>1/8"x5/8"L</p>	<p><b>F.</b> Quantity of 8</p>  <p>Screw <math>\Phi</math>1/8"x3/4"L</p>
<p><b>G</b> Quantity of 8</p>  <p>Screw <math>\Phi</math>1/4"x1/2"L</p>	<p><b>H</b> Quantity of 8</p>  <p>Back panel parts</p>	<p><b>I</b> Quantity of 16</p>  <p>Wood dowel <math>\Phi</math>5/16"x1-1/4"L</p>
<p><b>J</b> Quantity of 8</p>  <p>Cam bolt</p>	<p><b>K</b> Quantity of 8</p>  <p>Cam Lock</p>	<p><b>L</b> Quantity of 8</p>  <p>Cover</p>
<p><b>M</b> Quantity of 1</p>  <p>Left Arm Hinge</p>	<p><b>N</b> Quantity of 2</p>  <p>Hinge</p>	<p><b>O</b> Quantity of 2</p>  <p>Hinge</p>
<p><b>P</b> Quantity of 4</p>  <p>Plastic cap</p>	<p><b>Q</b> Quantity of 2</p>  <p>Bumper pipe</p>	<p><b>R</b> Quantity of 2</p>  <p>Bumper base</p>
<p><b>S</b> Quantity of 2</p>  <p>washer</p>	<p><b>T</b> Quantity of 1</p>  <p>Adjustable level</p>	<p><b>U</b> Quantity of 2</p>  <p>Wall anchor</p>

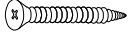
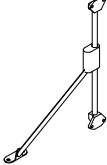
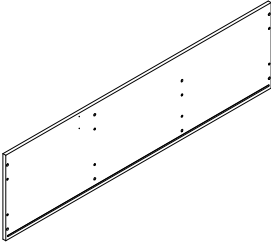
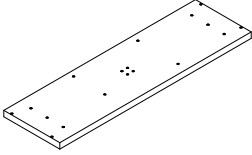
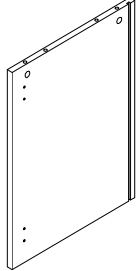
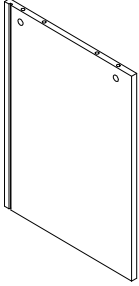
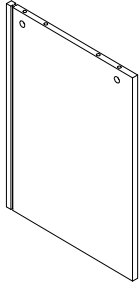
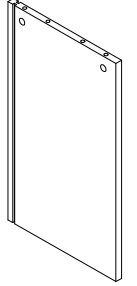
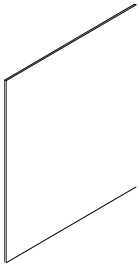
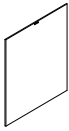
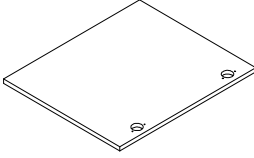
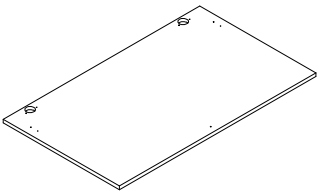
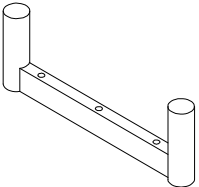
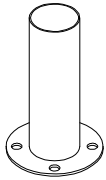
<p><b>V</b> Quantity of 6</p>  <p>Washer</p>	<p><b>W</b> Quantity of 2</p>  <p>Anti-tipping hardware</p>	<p><b>X</b> Quantity of 2</p>  <p>Wood screw <math>\Phi 1/8</math>"x1-1/2"L</p>
<p><b>Y</b> Quantity of 1</p>  <p>Right Arm Hinge</p>		
<p><b>1</b> Quantity of 1</p>  <p>Top Panel</p>	<p><b>2</b> Quantity of 1</p>  <p>Bottom Panel</p>	<p><b>3</b> Quantity of 1</p>  <p>Left side panel</p>
<p><b>4</b> Quantity of 1</p>  <p>Right side panel</p>	<p><b>5</b> Quantity of 1</p>  <p>Left vertical panel</p>	<p><b>6</b> Quantity of 1</p>  <p>Right Vertical panel</p>
<p><b>7</b> Quantity of 1</p>  <p>Middle Back Panel</p>	<p><b>8</b> Quantity of 2</p>  <p>Side Back Panel</p>	<p><b>9</b> Quantity of 1</p>  <p>Small Door</p>
<p><b>10</b> Quantity of 1</p>  <p>Big Door</p>	<p><b>11.</b> Quantity of 2</p>  <p>Side leg</p>	<p><b>12</b> Quantity of 1</p>  <p>Middle small leg</p>

# CM501400TX MORGANA CONSOLE

## Assembly Instructions

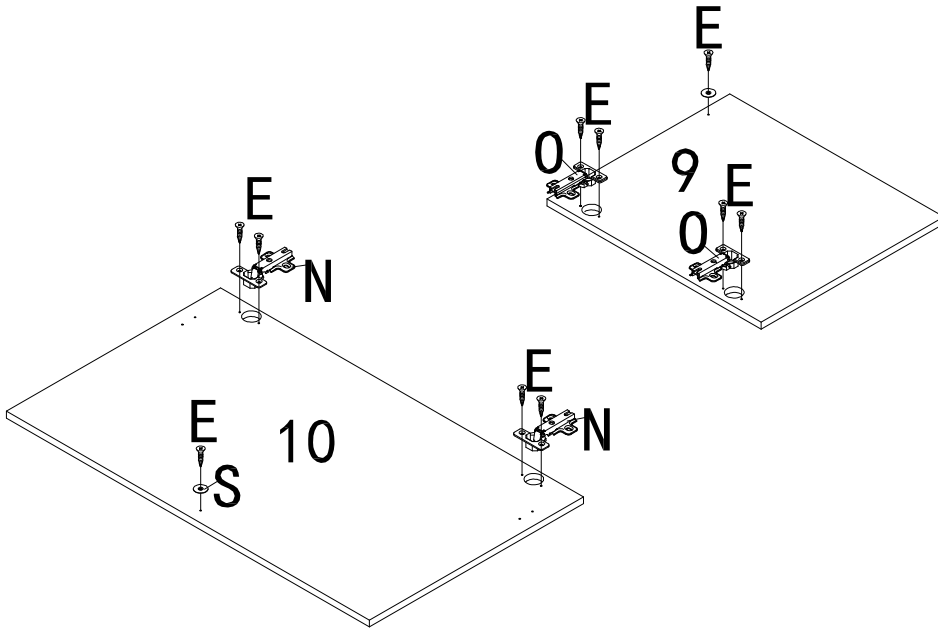
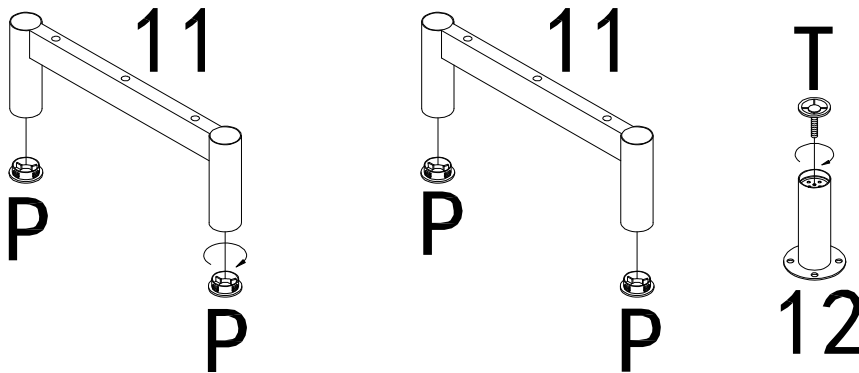

**Figure 1**

Attach Hinges (**O**) and Washers (**S**) to Small Door (**9**) with Screws (**E**).

Attach Hinges (**N**) and Washers (**S**) to Big Door (**10**) with Screws (**E**).

Tighten Screws (**E**) with Phillips screwdriver (not included).



**Figure 2**

Attach the Plastic Caps (**P**) to Side Legs (**11**).

Attach Adjustable Level (**T**) to Middle Small Leg (**12**)

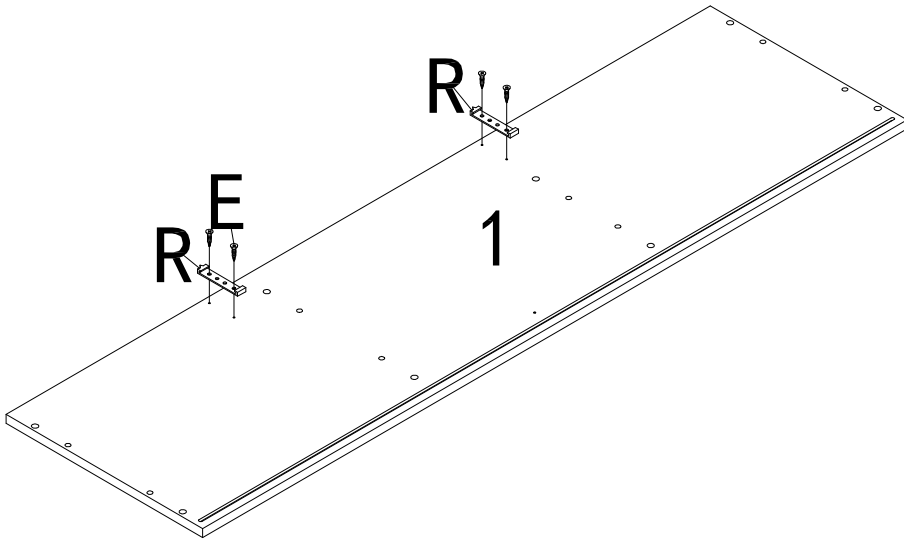

Attach Bumper Bases (**R**) to Top Panel (**1**) with Screws (**E**).

Tighten Sscrews with phillips screwdriver (not included).

**Figure 3**

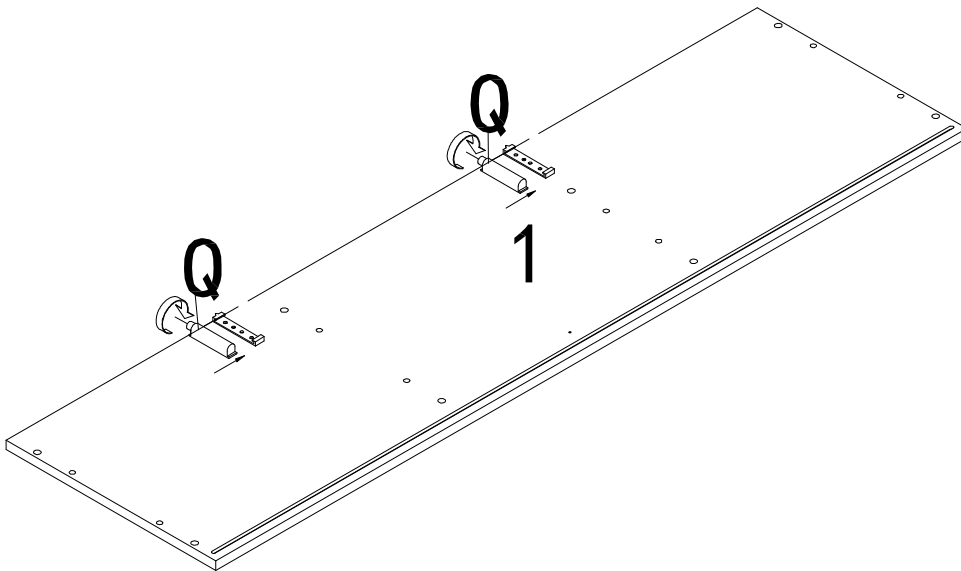

Insert Bumper Pipes (**Q**).

**Note:**

Bumper Pipes (**Q**) should be facing the front.

**Figure 4**

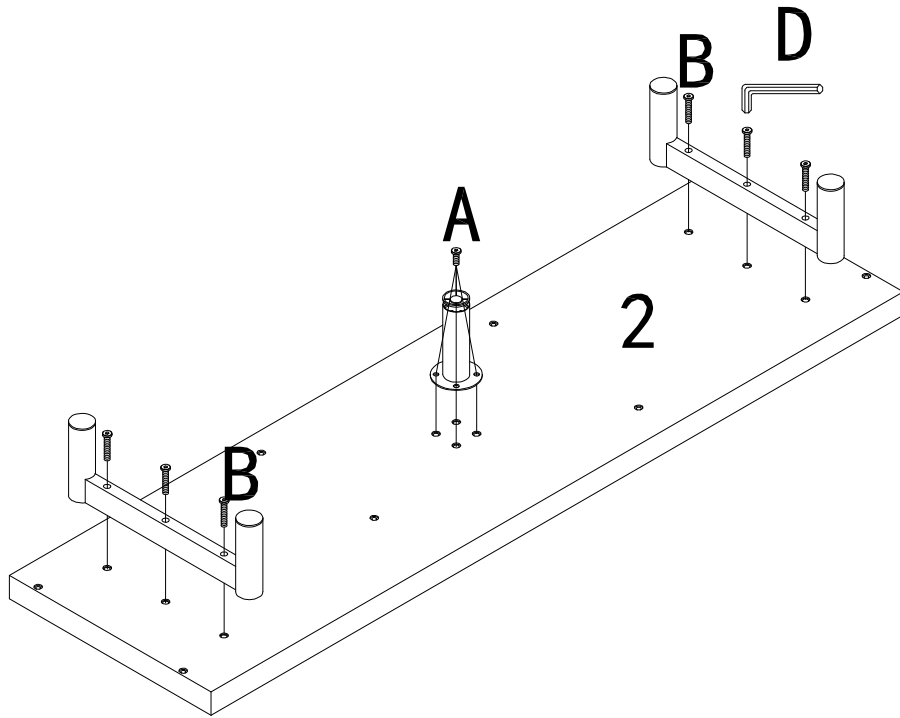

Attach Legs (11) to the Bottom Panel (2) with Bolts (A) and Bolts (B).

Tighten Bolts with Allen Wrench (D).

**Figure 5**

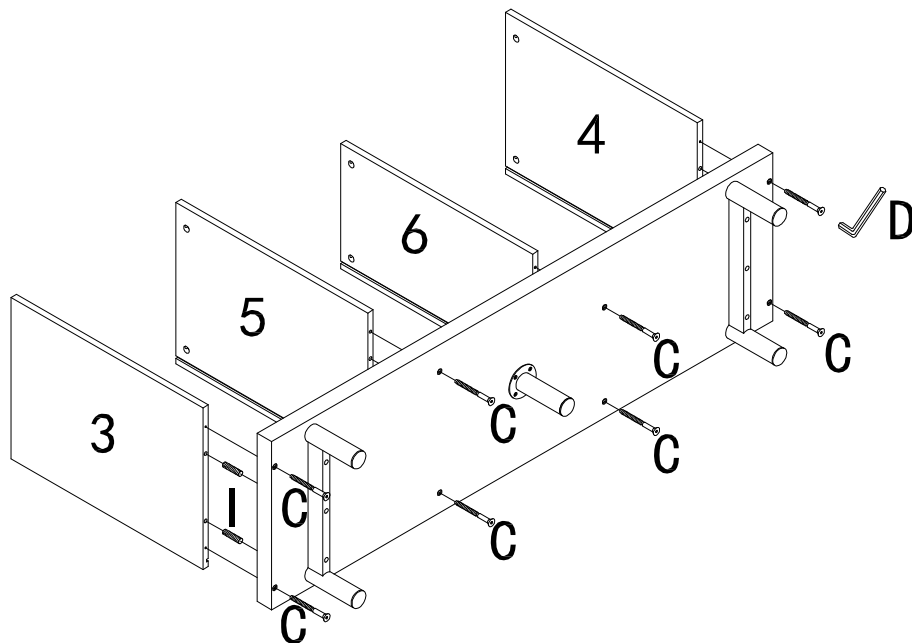

Attach Side Panels and Vertical Panels (3/4/5/6) to Bottom Panel with Bolts (C).

Tighten Bolts with Allen Wrench (D).

**Figure 6**

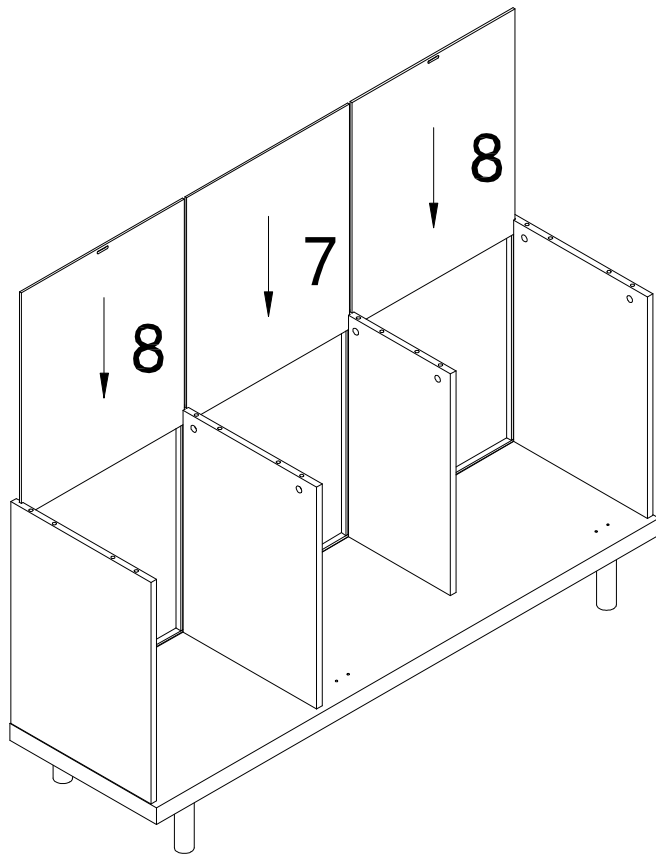

**Figure 7**

Insert Back Panels (**7/8**) into pre-assembled unit from Figure 6.

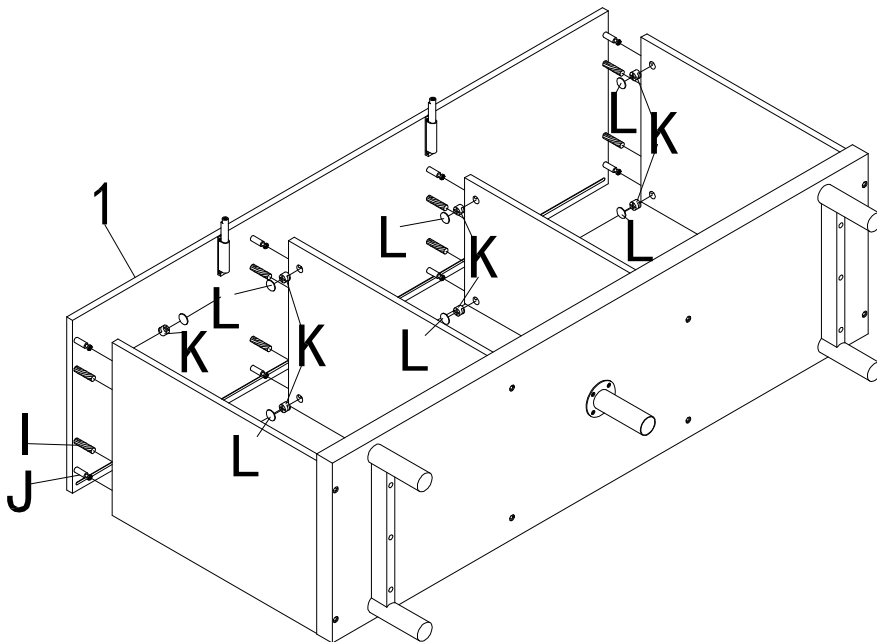

**Figure 8**

Insert Cam Locks (**K**) into holes on pre-assembled unit from figure 7.

Screw Cam Bolts (**J**) into holes on Top Panel (**1**).

Attach Top Panel (**1**) to pre-assembled unit from figure 7 by inserting Wood Dowels (**I**) and Cam Bolts (**J**) into corresponding holes until panels meet.

Tighten by rotating Cam Locks (**K**) clockwise with Phillips Screwdriver (not included).

Cover cam lock holes with Covers (**L**)

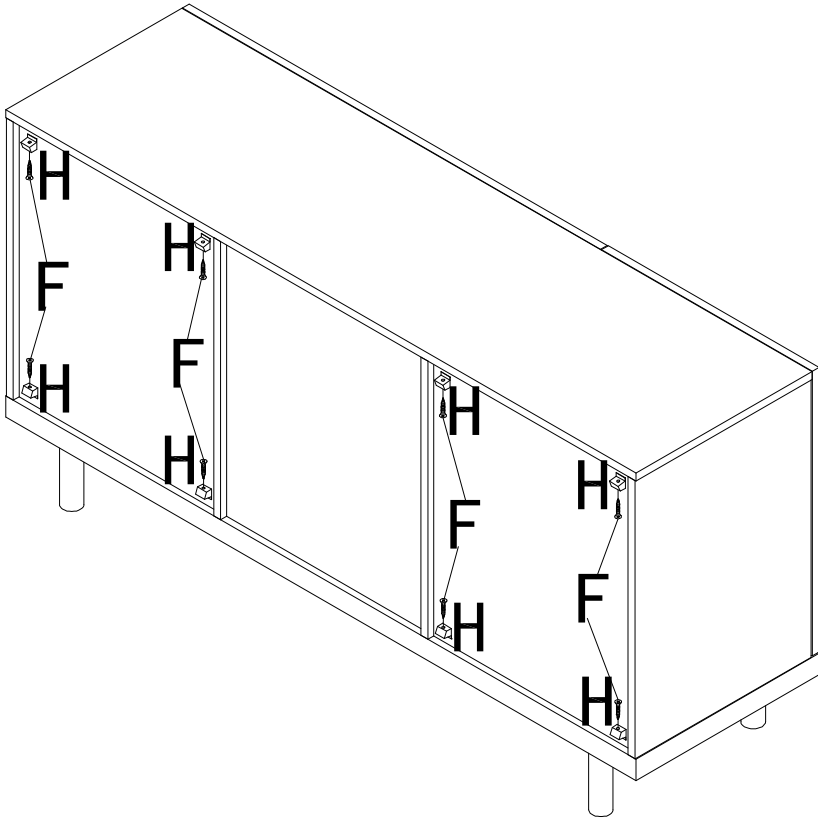

Attach Back Panel Parts (**H**) to back of the unit with Screws (**F**).

Tighten Screws with Phillips Screwdriver (not included).

**Figure 9**

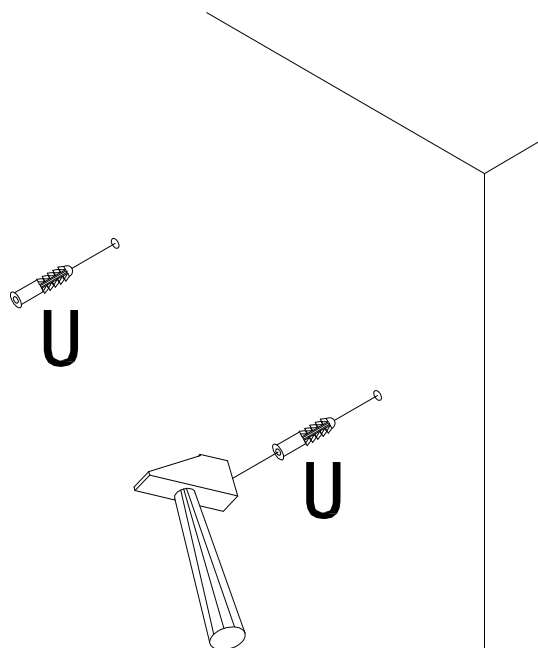

Mark two desired locations on wall.

Drill two 3/16" holes on wall.

Insert plastic anchors (**U**) into the 2 holes on wall.

(When doing this, you will need a hammer help you).

**Figure 10**



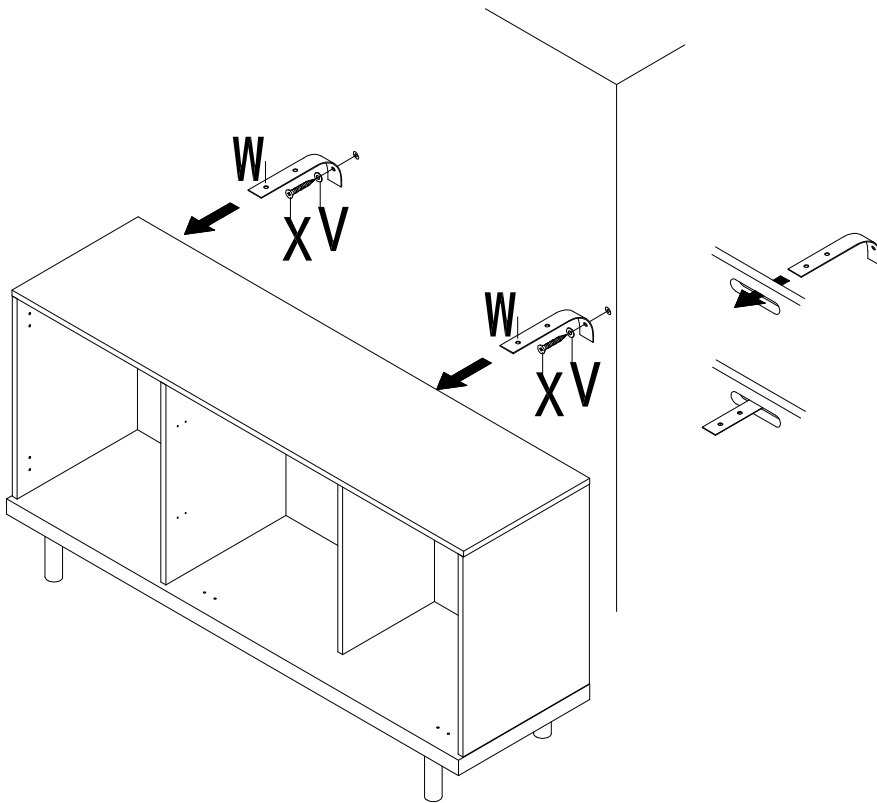

Attach the Anti-tipping Hardware (**W**) to Plastic Anchors with Wood Screws (**X**) and Washers (**V**).

Tighten screw with Phillips Screwdriver (not included).

Move the unit close to the Anti-tipping Hardware (**W**) and insert Anti-tipping Hardware (**W**) through Back Panels (**8**).

**Figure 11**

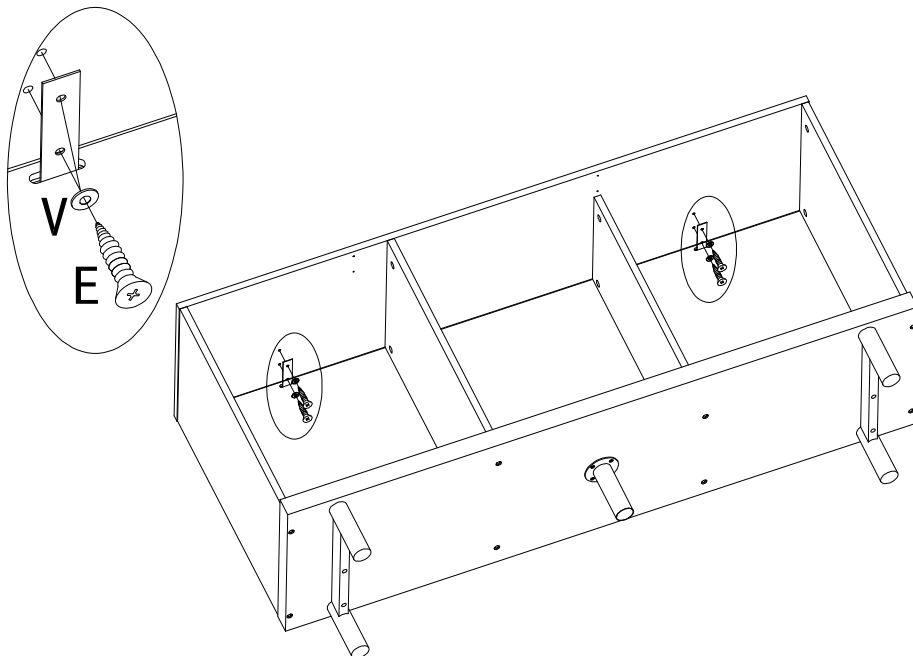

Attach Anti-tipping Hardware (**W**) to Top Panel with Washers (**V**) and Screws (**E**).

Tighten screw with Phillips Screwdriver(not included)

**Warning: Anti-tipping hardware must be used for this product to avoid tipping and injury.**

**Figure 12**

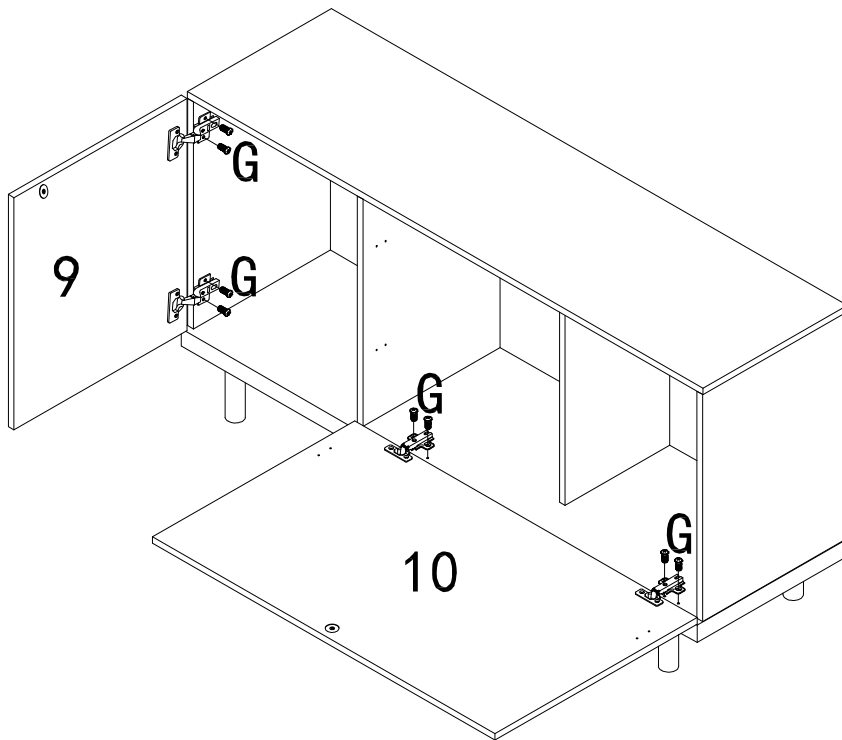

**Figure 13**

Attach pre-assembled units from Figure 1 to pre-assembled unit from Figure 7 with Screws **(G)**.

Tighten Screws with Phillips Screwdriver (not included)

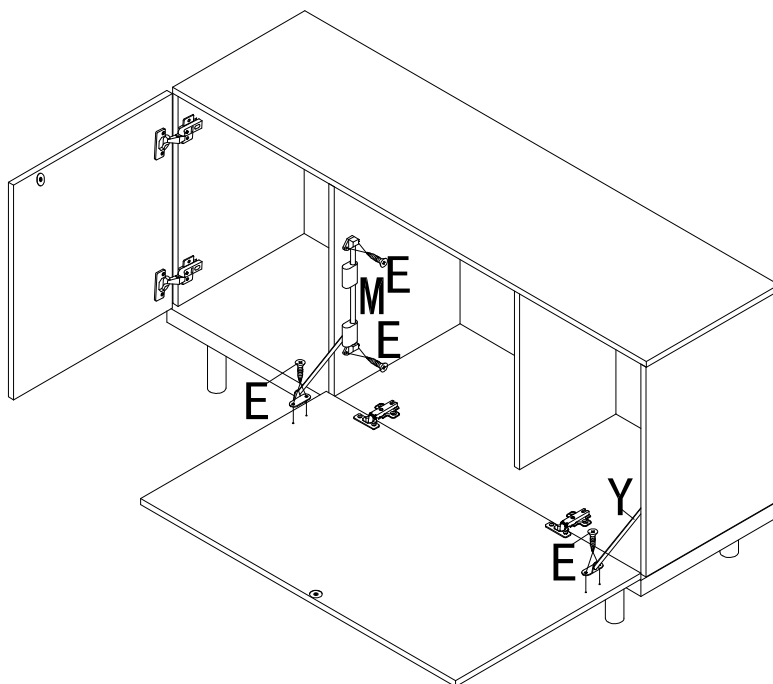

**Figure 14**

Attach Arm Hinges **(M/Y)** to pre-assembled unit from Figure 8 with Screws **(E)**.

Tighten Screws with Phillips Screwdriver.

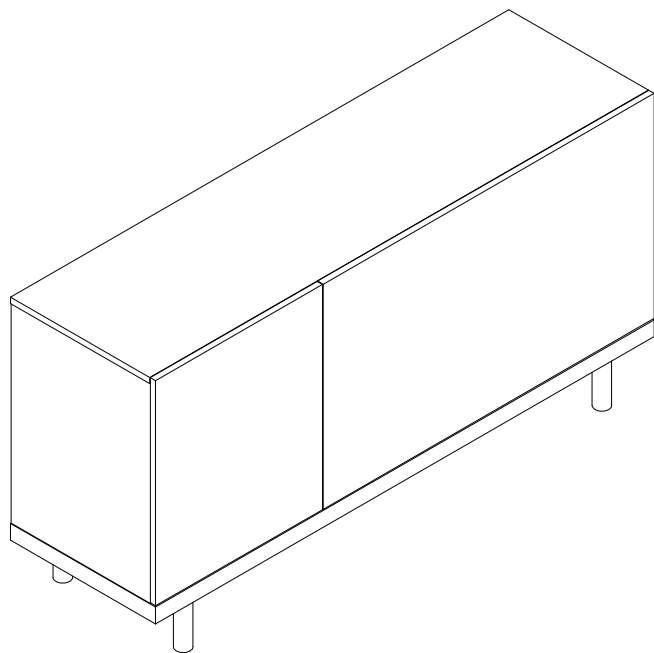

Now your Morgana Console is ready for use!

**Figure 15**

# Parts Replacement Form

## Customer Information

Name \_\_\_\_\_

Address \_\_\_\_\_

City/State/Zip Code \_\_\_\_\_

Phone Number \_\_\_\_\_

Please indicate where you purchased this item: Store/Website/Catalog

\_\_\_\_\_

Please indicate color/size/style number:

\_\_\_\_\_

Style No	Parts Letter	Parts Description	Quantity Needed
_____	_____	_____	_____
_____	_____	_____	_____
_____	_____	_____	_____

Please immediately examine this product carefully. Any request for missing parts or damage replacement must be received within 90 days of your receipt of the product. Replacement, if available, will be honored within this time frame. Parts will not be available for items arriving fully assembled. We do not recommend modifying product(s) and we are not responsible for any damages due to product modification(s). If damages or missing parts are not reported within 90 days of your receipt, we are under no obligation to provide parts or replacement merchandise. Please contact Southern Enterprises at 800-633-5096 or in Dallas 972-869-0111/ 9am – 4pm Mon-Fri Central time if you have product issues or email us at [service@seidal.com](mailto:service@seidal.com). Please ask for customer service representative for issues involving damages or replacement parts. Please ask for technical assistance representative for any issues with product and assembly/construction.

Please contact the retailer that you purchased from for returns.



**Southern**  
ENTERPRISES

Customer Service 1-800-633-5096  
[service@seidal.com](mailto:service@seidal.com)  
Southern Enterprises, Inc.  
600 Freeport Parkway, Suite 200  
Coppell, Texas 75019