

HZ030500TX

# Wyman Tiered Storage Cabinet

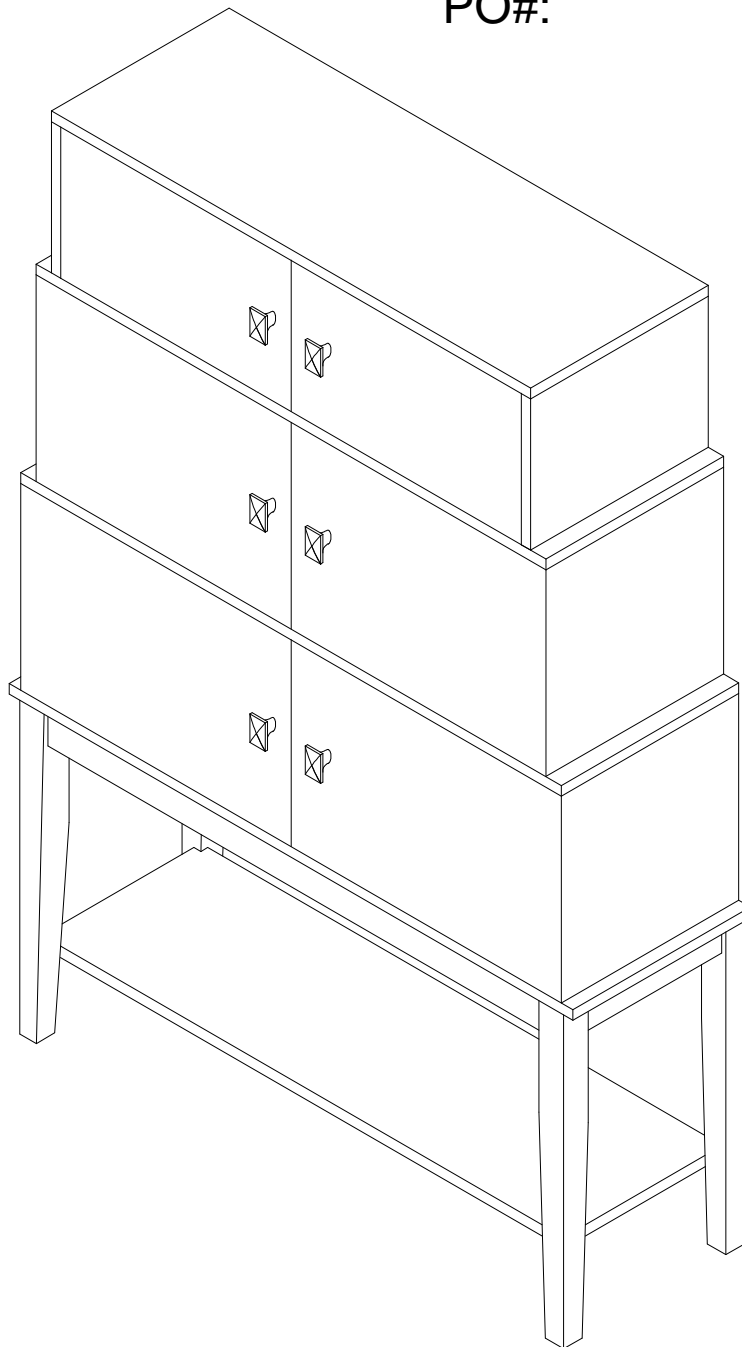
## Assembly Instructions



**Southern**  
ENTERPRISES

For assistance with assembly, contact:  
Southern Enterprises, Inc.  
Customer Service: 1-800-633-5096  
service@seidal.com  
www.seifurniturestore.com

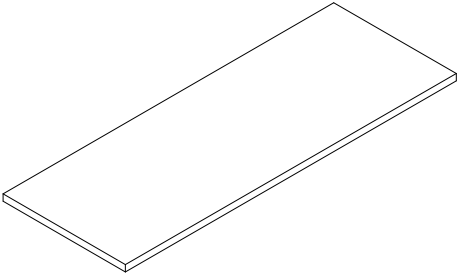
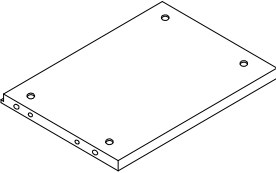
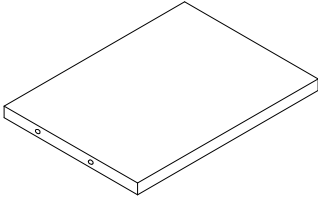
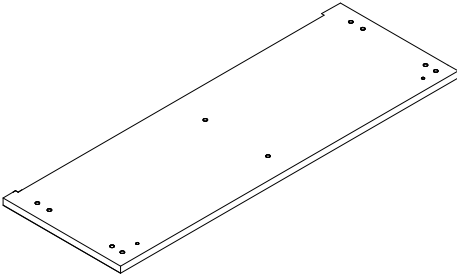
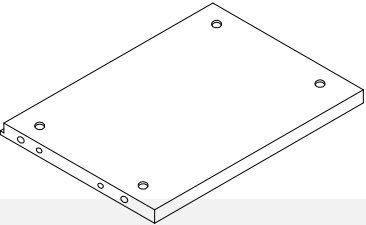
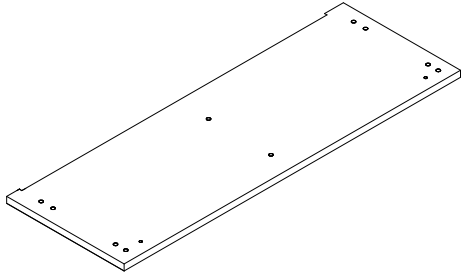
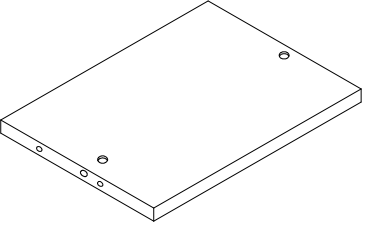
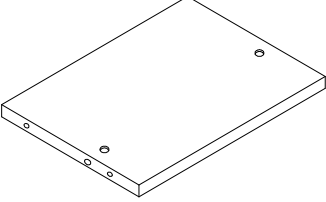
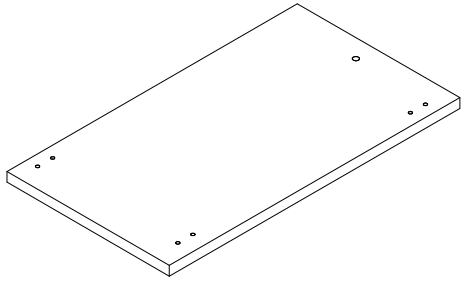
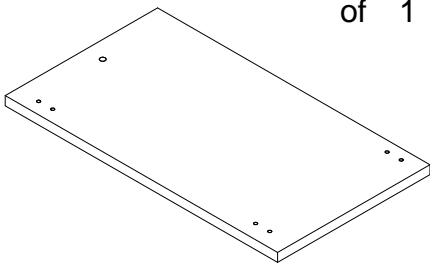
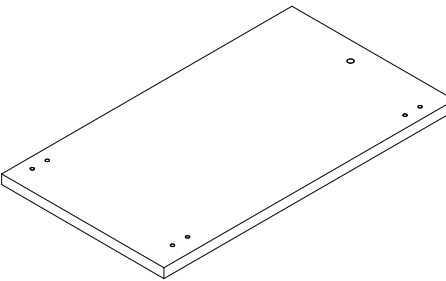
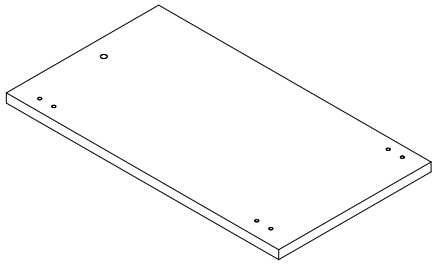
PO#:

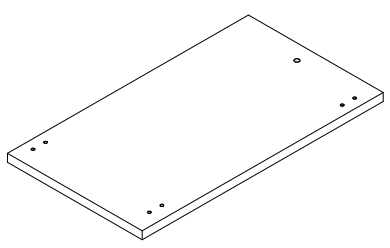
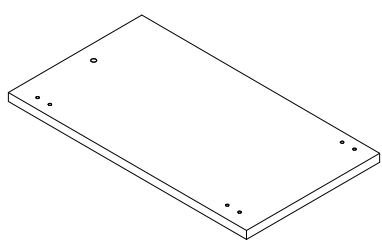
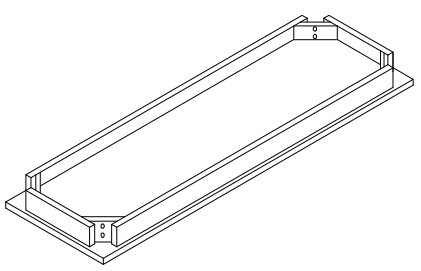
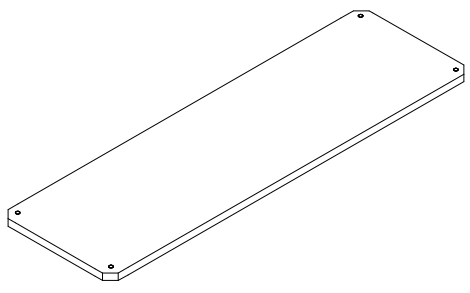
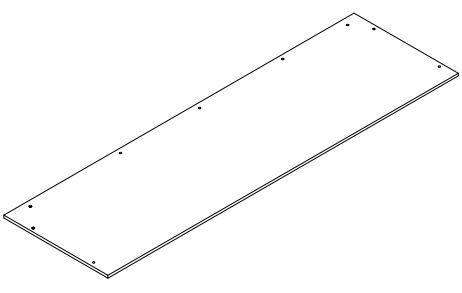
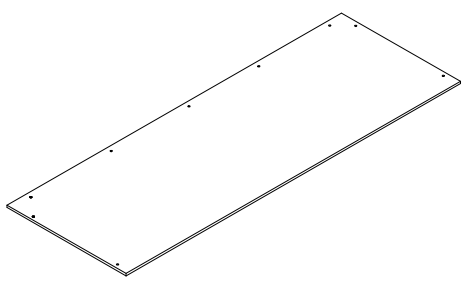
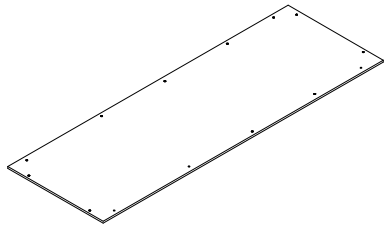
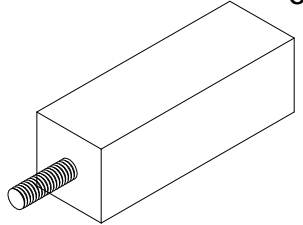
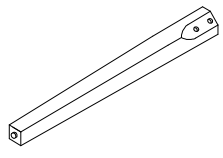

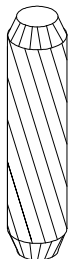
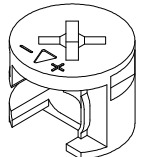

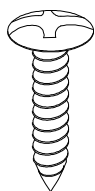
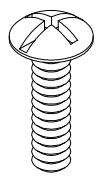


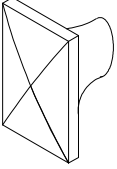
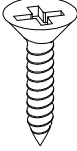
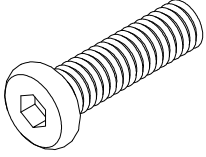
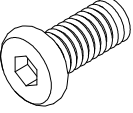
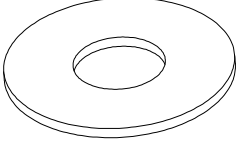
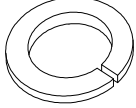
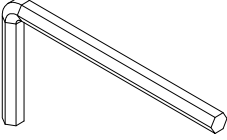
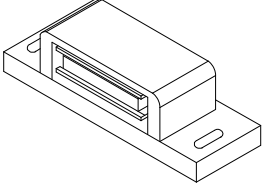
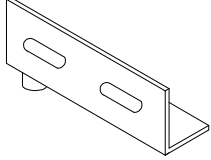
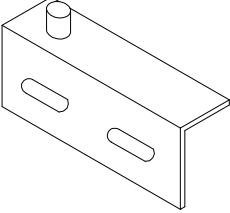
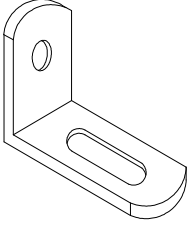
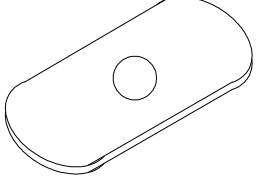
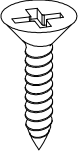
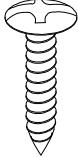
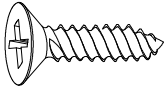
# Wyman Tiered Storage Cabinet

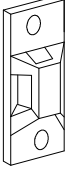
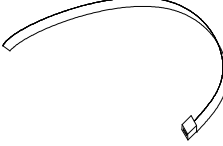
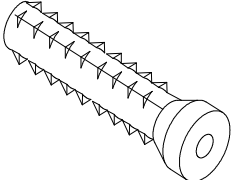
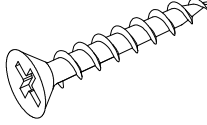
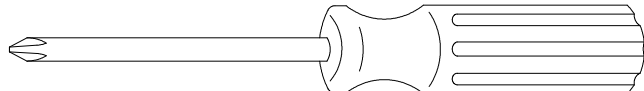
## Parts List

Please check packaging for all parts and hardware before discarding. Unpack and lay parts on clean, padded surface like carpet or blanket. Check that you have all parts indicated. Call customer service if hardware is missing. Before beginning assembly, carefully study the diagrams below and sort your hardware according to the pictures. Using the incorrect hardware will cause damage.

<p>1) Quantity of 1</p>  <p>Top Panel</p>	<p>2) Quantity of 2</p>  <p>Top Side Panel</p>	<p>3) Quantity of 1</p>  <p>Top Vertical Panel</p>
<p>4) Quantity of 1</p>  <p>Second Top Panel</p>	<p>5) Quantity of 4</p>  <p>Third Side Panel</p>	<p>6) Quantity of 1</p>  <p>Third Top Panel</p>
<p>7) Quantity Of 1</p>  <p>Second Vertical Panel</p>	<p>8) Quantity of 1</p>  <p>Third Vertical Panel</p>	<p>9L) Quantity of 1</p>  <p>Left Top Door Panel</p>
<p>9R) Quantity of 1</p>  <p>Right Top Door Panel</p>	<p>10L) Quantity of 1</p>  <p>Middle Left Door Panel</p>	<p>10R) Quantity of 1</p>  <p>Middle Right Door Panel</p>

<p>11L) Quantity of 1</p>  <p>Bottom Left Door Panel</p>	<p>11R) Quantity of 1</p>  <p>Bottom Right Door Panel</p>	<p>12) Quantity of 1</p>  <p>Fourth Top Panel</p>
<p>13) Quantity of 1</p>  <p>Bottom Panel</p>	<p>14) Quantity of 1</p>  <p>Top Back Panel</p>	<p>15) Quantity of 1</p>  <p>Middle Back Panel</p>
<p>16) Quantity of 1</p>  <p>Bottom Back Panel</p>	<p>17) Quantity of 1</p>  <p>Adjustable Leg</p>	<p>18) Quantity of 4</p>  <p>Leg</p>
<p>A) Quantity of 30</p>  <p>Cam Bolts</p>	<p>B) Quantity of 36</p>  <p>Wood Dowels Dia. 5/16"x1-1/4</p>	<p>C) Quantity of 30</p>  <p>Cam Locks</p>
<p>D) Quantity of 30</p>  <p>Cover</p>	<p>E) Quantity of 24</p>  <p>Screw Dia. 1/8" x 1/2"L</p>	<p>F) Quantity of 6</p>  <p>Bolts Dia. 5/32"x3/4"</p>

<p><b>G)</b> Quantity of 6</p>  <p>Knob</p>	<p><b>H)</b> Quantity of 12</p>  <p>Screw Dia. 1/8" x 5/8"L</p>	<p><b>I)</b> Quantity of 8</p>  <p>Bolts Dia. 1/4" x 1-3/4" L</p>
<p><b>J)</b> Quantity of 8</p>  <p>Bolts Dia. 1/4" x 1/2" L</p>	<p><b>L)</b> Quantity of 16</p>  <p>Flat Washer</p>	<p><b>M)</b> Quantity of 16</p>  <p>Spring Washer</p>
<p><b>N)</b> Quantity of 1</p>  <p>Allen Wrench 4MM</p>	<p><b>O)</b> Quantity of 6</p>  <p>Magnet</p>	<p><b>PL)</b> Quantity of 6</p>  <p>Hinge</p>
<p><b>PR)</b> Quantity of 6</p>  <p>Hinge</p>	<p><b>Q)</b> Quantity of 4</p>  <p>Iron Bracket</p>	<p><b>R)</b> Quantity of 6</p>  <p>Iron Plate</p>
<p><b>S)</b> Quantity of 6</p>  <p>Screw Dia. 1/8" x 1/2"L</p>	<p><b>T)</b> Quantity of 32</p>  <p>Screw Dia. 1/8" x 5/8"L</p>	<p><b>U)</b> Quantity of 4</p>  <p>Screw Dia. 1/8" x 5/8"L</p>

<p><b>V)</b> Quantity of 4</p>  <p>Bracket</p>	<p><b>W)</b> Quantity of 2</p>  <p>Plastic chain</p>	<p><b>X)</b> Quantity of 4</p>  <p>Anchor</p>
<p><b>Y)</b> Quantity of 4</p>  <p>Screw Dia1/8"x1-3/8"L</p>		
<p><b>Care and Cleaning Instructions:</b>          Before using, wipe with a clean, dry cloth. Periodically apply furniture wax to renew the finish. Avoid rubbing or scratching the surface with rough or abrasive objects.</p>		<p>For replacement parts or questions, please call SEI Customer Service at 1-800-633-5096.</p>
<p><b>Assembly Tool Required:</b>          No.2 Phillips Screwdriver, Hammer          (Not Included)</p>		

# Wyman Tiered Storage Cabinet

## Assembly Instructions

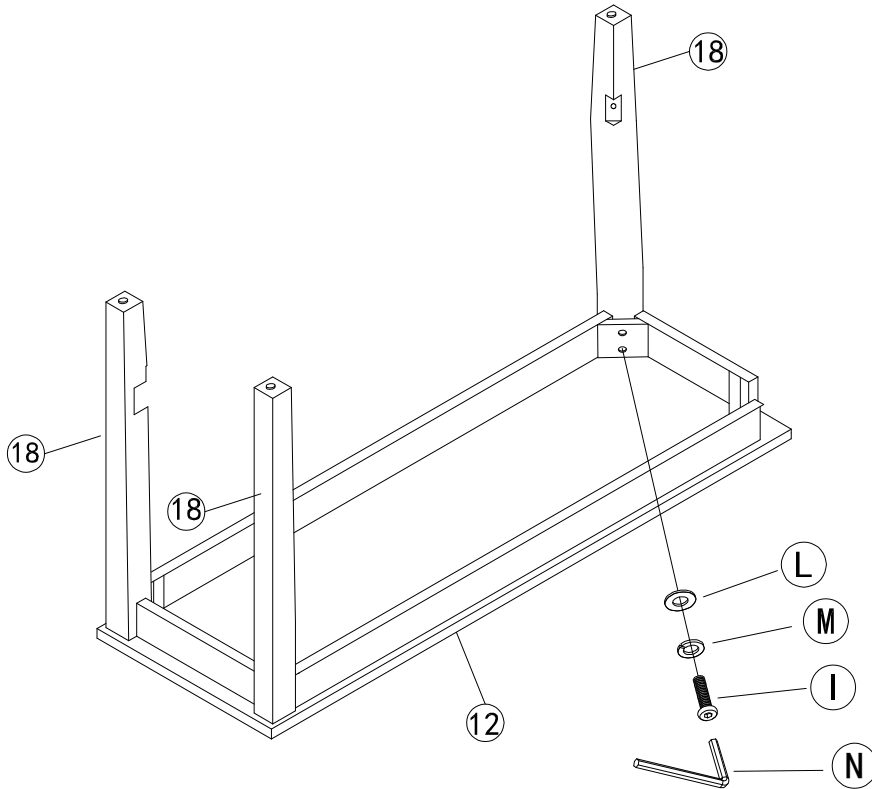


Figure 1

Attach three Legs **(18)** to the Fourth Top Panel **(12)** with Bolts **(I)**, Spring Washers **(M)**, and Flat Washers **(L)**.

Tighten Bolts **(I)** with Allen Wrench **(N)**.

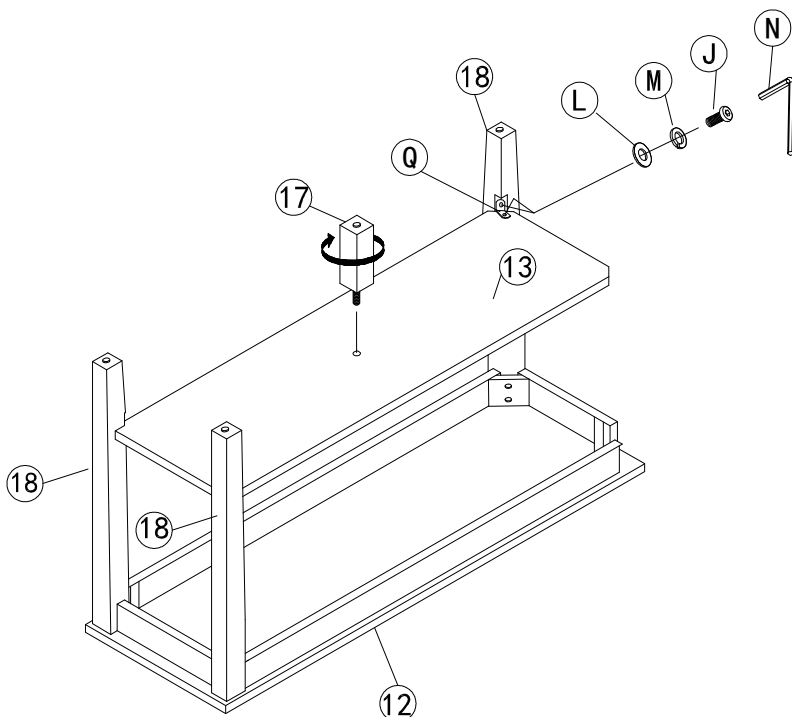
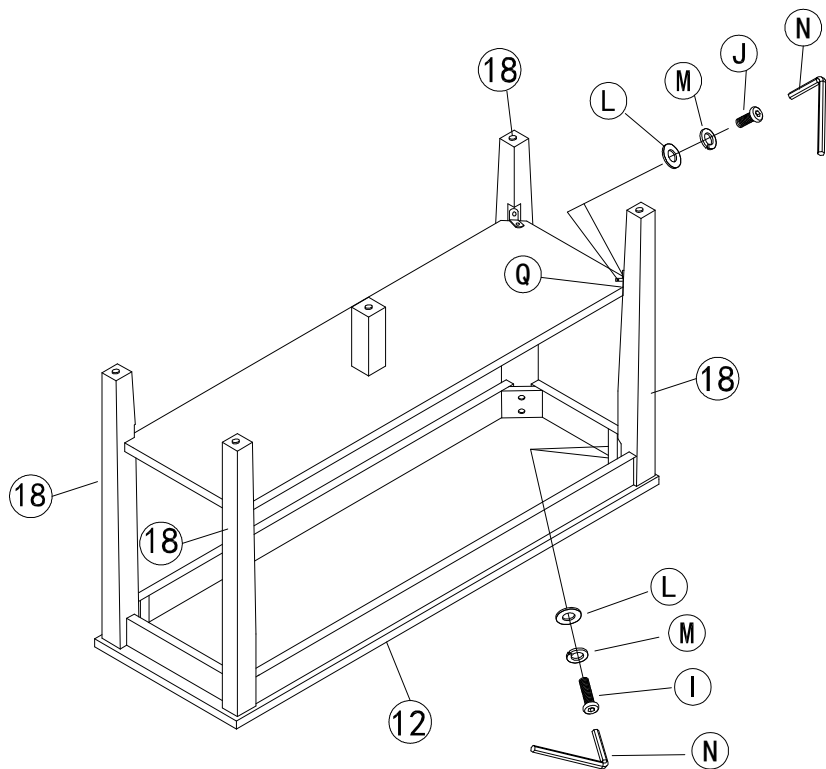


Figure 2

Attach Bottom Panel **(13)** to pre-assembled unit from Figure 1 with Iron Brackets **(Q)**, Bolts **(J)**, Spring Washers **(M)**, and Flat Washers **(L)**.

Tighten Bolts **(J)** with Allen Wrench **(N)**.

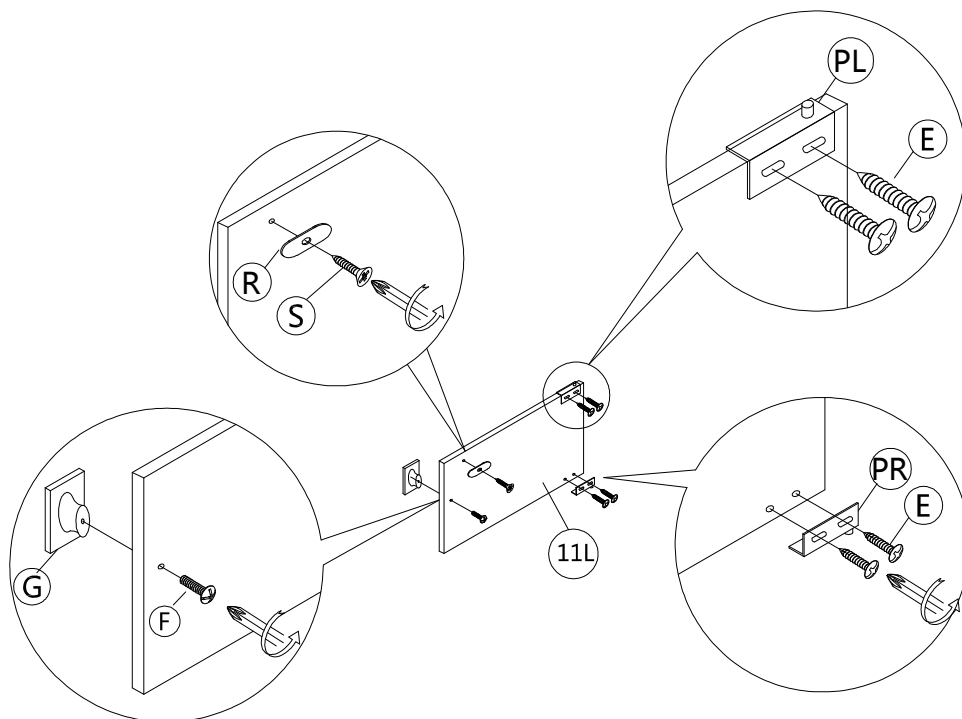
Attach Adjustable Leg **(17)** to pre-assembled unit from Figure 1 by hand.



**Figure 3**

Attach the Fourth Leg (**18**) to pre-assembled unit from Figure 2 with Brackets (**Q**), Bolts (**J/I**), Spring Washers (**M**), and Flat Washers (**L**).

Tighten Bolts (**J/I**) with Allen Wrench (**N**).



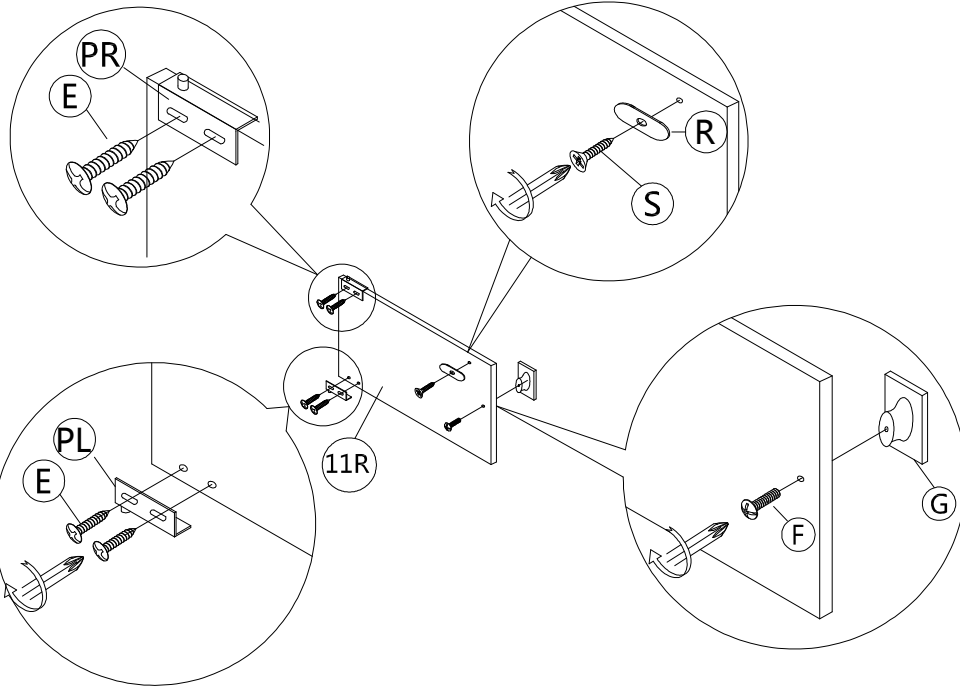
**Figure 4**

Attach Hinges (**PL/PR**) to Bottom Left Door Panel (**11L**) with Screws (**E**).

Attach Iron Plate (**R**) to Bottom Left Door Panel (**11L**) with Screw (**S**).

Attach Knob (**G**) to Bottom Left Door Panel (**11L**) with Bolt (**F**).

Tighten Bolt (**F**) and Screws (**E/S**) with Phillips screwdriver (not included).



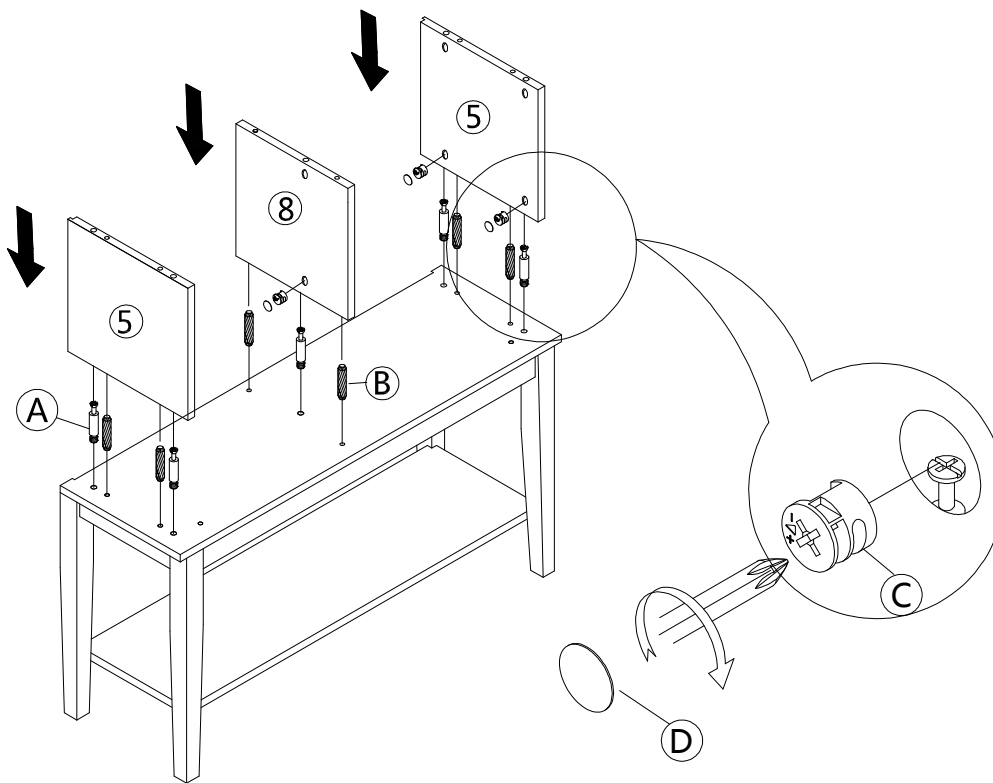
**Figure 5**

Attach Hinges (**PL/PR**) to Bottom Right Door Panel (**11R**) with Screws (**E**).

Attach Iron Plate (**R**) to Bottom Right Door Panel (**11R**) with Screw (**S**).

Attach Knob (**G**) to Bottom Right Door Panel (**11R**) with Bolt (**F**).

Tighten Bolt (**F**) and Screws (**E/S**) with Phillips screwdriver (not included).



**Figure 6**

Insert Cam Locks (**C**) into Third Side Panels (**5**) and Third Vertical Panel (**8**).

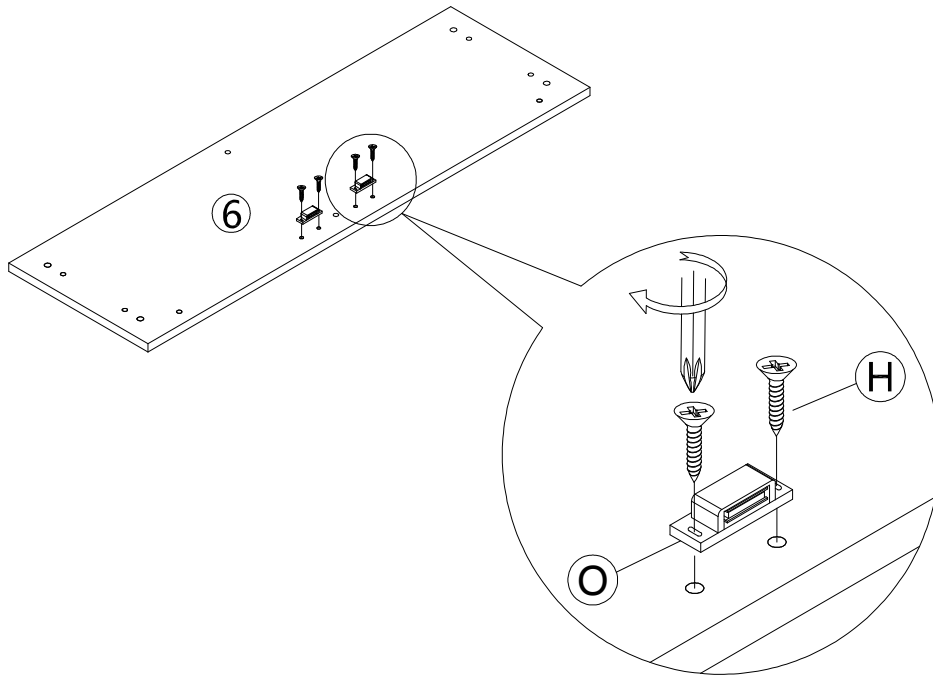
Screw Cam Bolts (**A**) into threaded holes on pre-assembled unit from Figure 3.

Attach Third Side Panels (**5**) and Third Vertical Panel (**8**) to pre-assembled unit from Figure 3 by inserting Cam Bolts (**C**) and Wood Dowels (**B**) into corresponding holes until all panels meet.

Tighten Cam Bolts (**A**) by rotating Cam Locks (**C**) clockwise using Phillips screwdriver (not included).

Cover Cam Lock Holes with Covers (**D**).

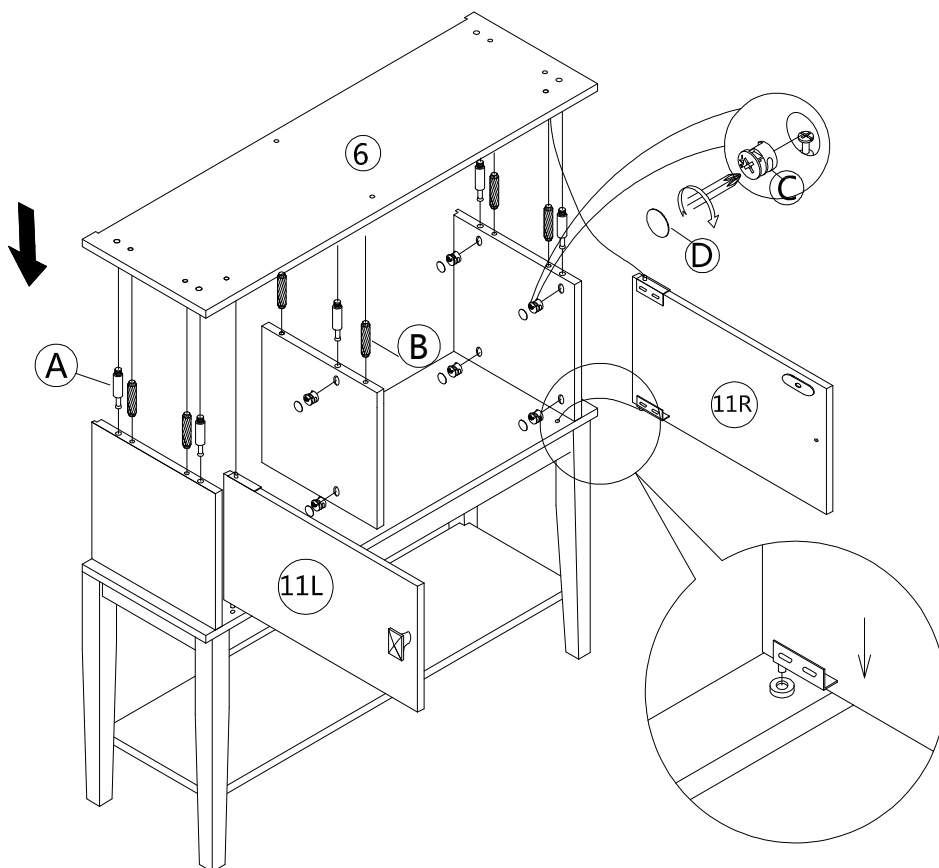




**Figure 7**

Attach Magnets **(O)** to Third Top Panel **(6)** with Screws **(H)**.

Tighten Screws **(H)** with Phillips screwdriver (not included).



**Figure 8**

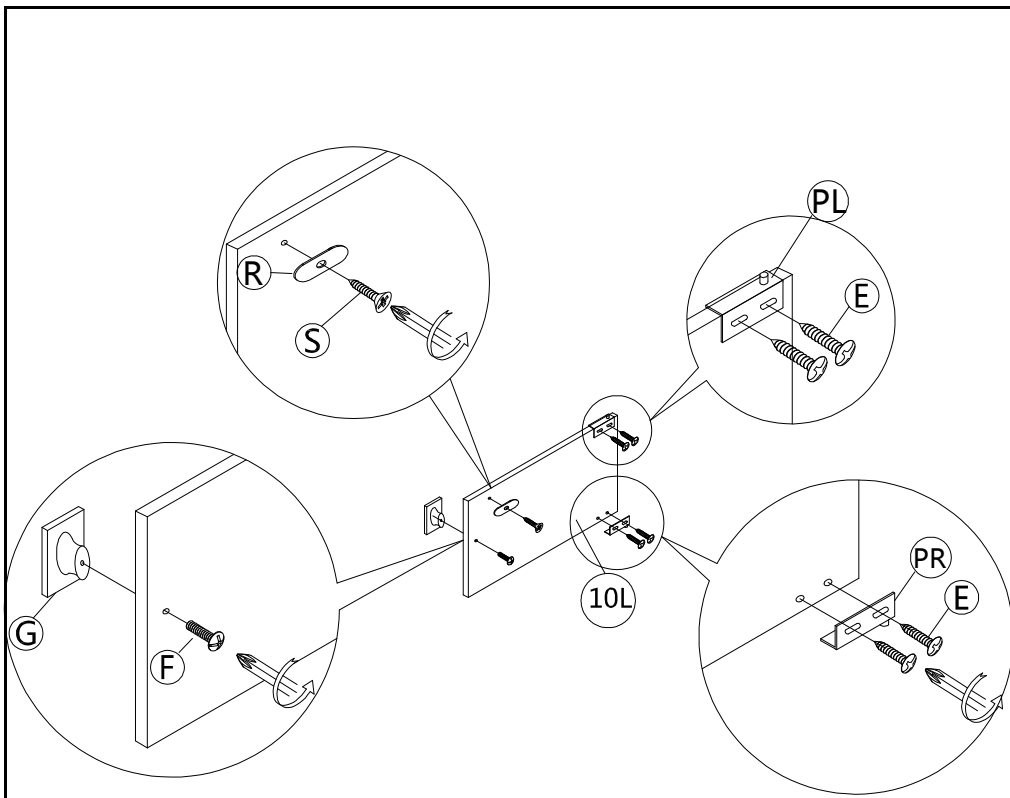
Insert Cam Locks **(C)** into corresponding holes on pre-assembled unit from Figure 6.

Screw Cam Bolts **(A)** into threaded holes on Third Top Panel **(6)**.

Attach Bottom Doors **(11L/1R)** to pre-assembled unit from Figure 6 by inserting lower hinges into corresponding holes. Upper hinges will connect to holes in Third Top Panel **(6)**.

Attach Third Top Panel **(6)** to pre-assembled unit from Figure 6 by inserting Cam Bolts **(A)** and Wood Dowels **(B)** into corresponding holes until all panels meet.

Tighten Cam Bolts **(A)** by rotating Cam Locks **(B)** clockwise using Phillips screwdriver (not included).



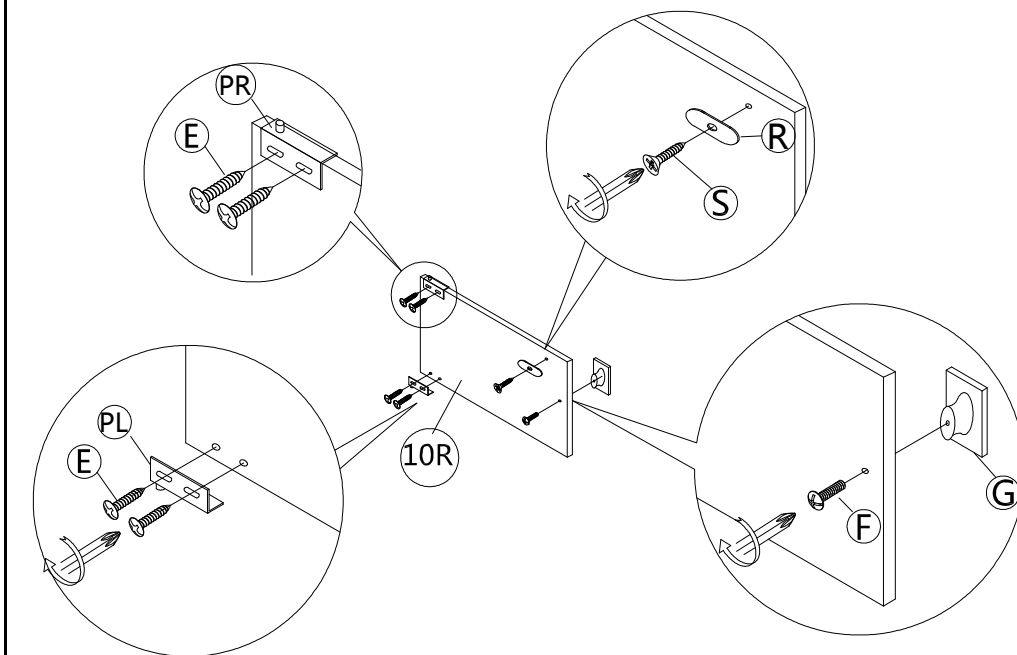
**Figure 9**

Attach Hinges (**PL/PR**) to Middle Left Door Panel (**10L**) with Screws (**E**).

Attach Iron Plate (**R**) to Middle Left Door Panel (**10L**) with Screw (**S**).

Attach Knob (**G**) to Middle Left Door Panel (**10L**) with Bolt (**F**).

Tighten Bolt (**F**) and Screws (**E/S**) with Phillips screwdriver (not included).



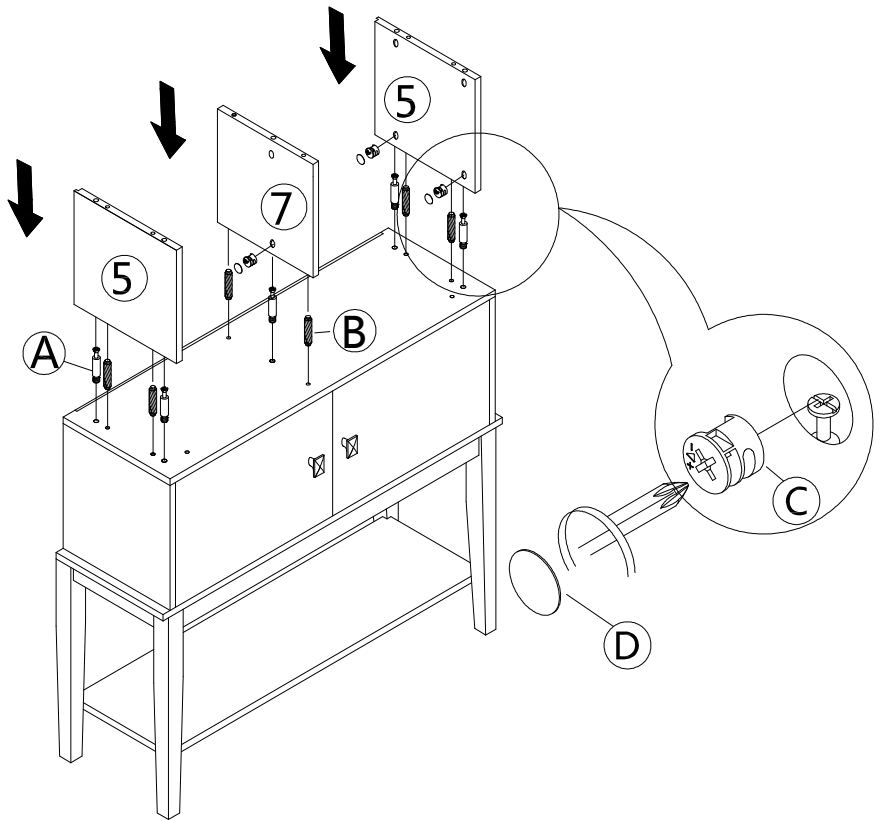
**Figure 10**

Attach Hinges (**PL/PR**) to Middle Right Door Panel (**10R**) with Screws (**E**).

Attach Iron Plate (**R**) to Middle Right Door Panel (**10R**) with Screw (**S**).

Attach Knob (**G**) to Middle Right Door Panel (**10R**) with Bolt (**F**).

Tighten Bolt (**F**) and Screws (**E/S**) with Phillips screwdriver (not included).



**Figure 11**

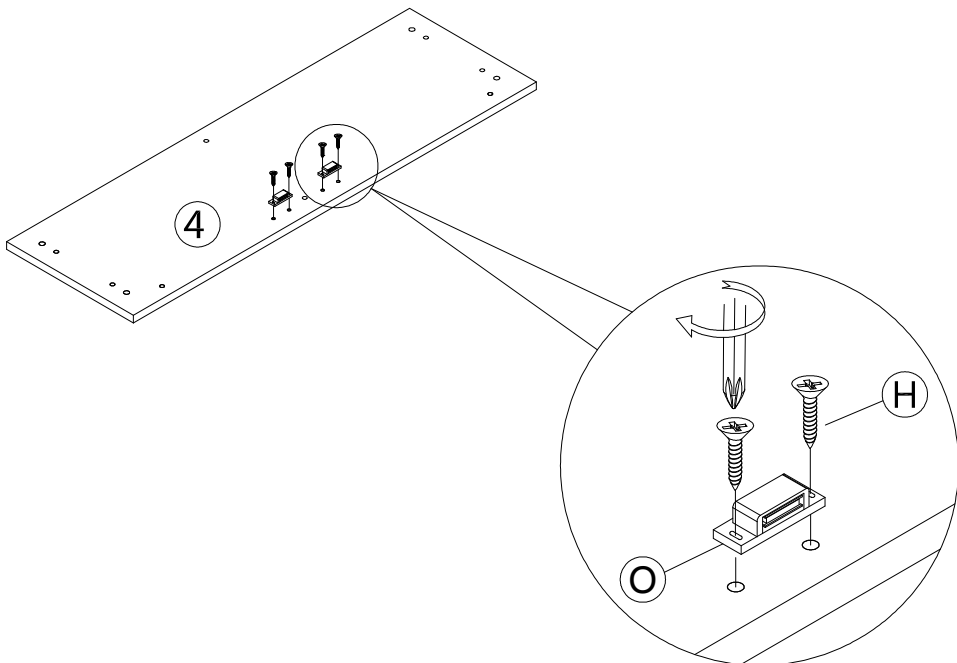
Insert Cam Locks **(C)** into Third Side Panels **(5)** and Second Vertical Panel **(7)**.

Screw Cam Bolts **(A)** into threaded holes on pre-assembled unit from Figure 8.

Attach Third Side Panels **(5)** and Second Vertical Panel **(7)** to pre-assembled unit from Figure 8 by inserting Cam Bolts **(C)** and Wood Dowels **(B)** into corresponding holes until all panels meet.

Tighten Cam Bolts **(A)** by rotating Cam Locks **(C)** clockwise using Phillips screwdriver (not included).

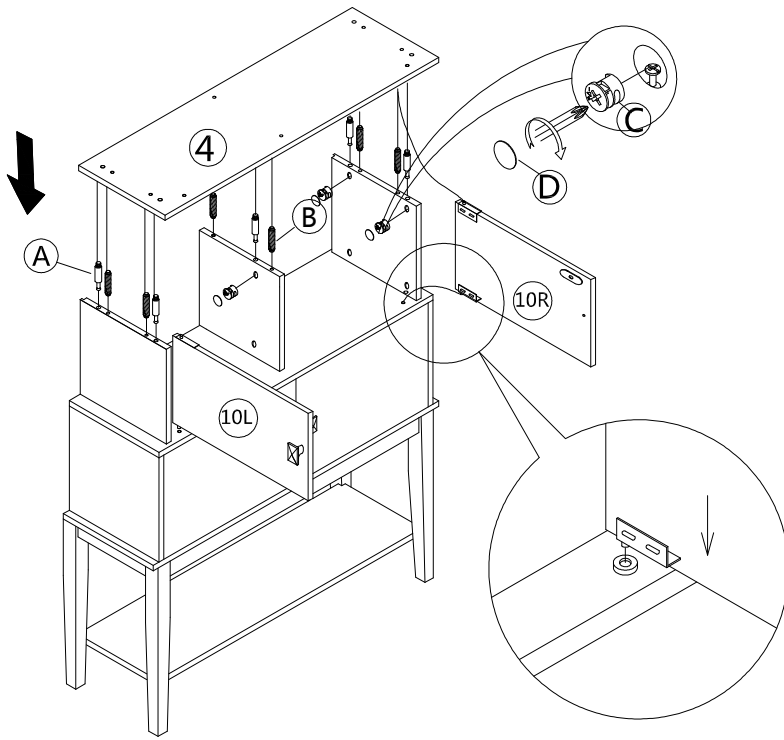
Cover Cam Lock Holes with Covers **(D)**.



**Figure 12**

Attach Magnets **(O)** to Second Top Panel **(4)** with Screws **(H)**.

Tighten Screws **(H)** with Phillips screwdriver (not included).



**Figure 13**

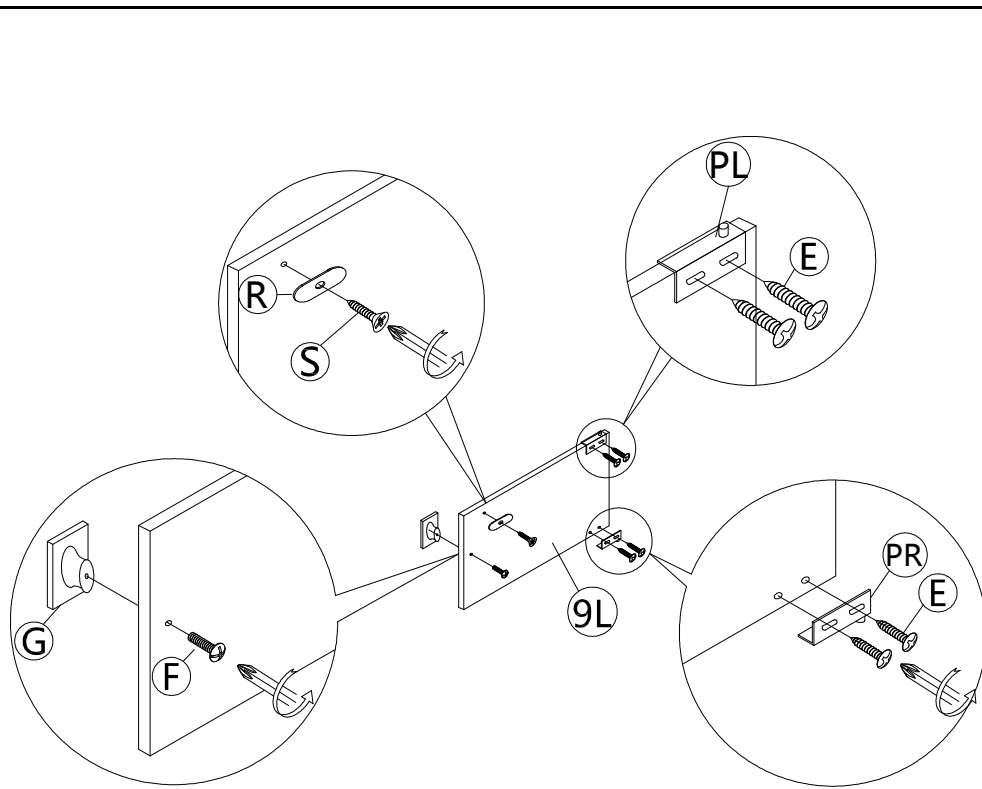
Insert Cam Locks **(C)** into corresponding holes on pre-assembled unit from figure 11.

Screw Cam Bolts **(A)** into threaded holes on Second Top Panel **(4)**.

Attached Middle Doors **(10L/10R)** to pre-assembled unit from Figure 11 by inserting lower hinges into corresponding holes. Upper hinges will fit into holes on Second Top Panel **(4)**

Attach Second Top Panel **(4)** to pre-assembled unit from Figure 11 by inserting Cam Bolts **(A)** and Wood Dowels **(B)** into corresponding holes until all panels meet.

Tighten Cam Bolts **(A)** by rotating Cam Locks **(B)** clockwise using Phillips screwdriver (not included).



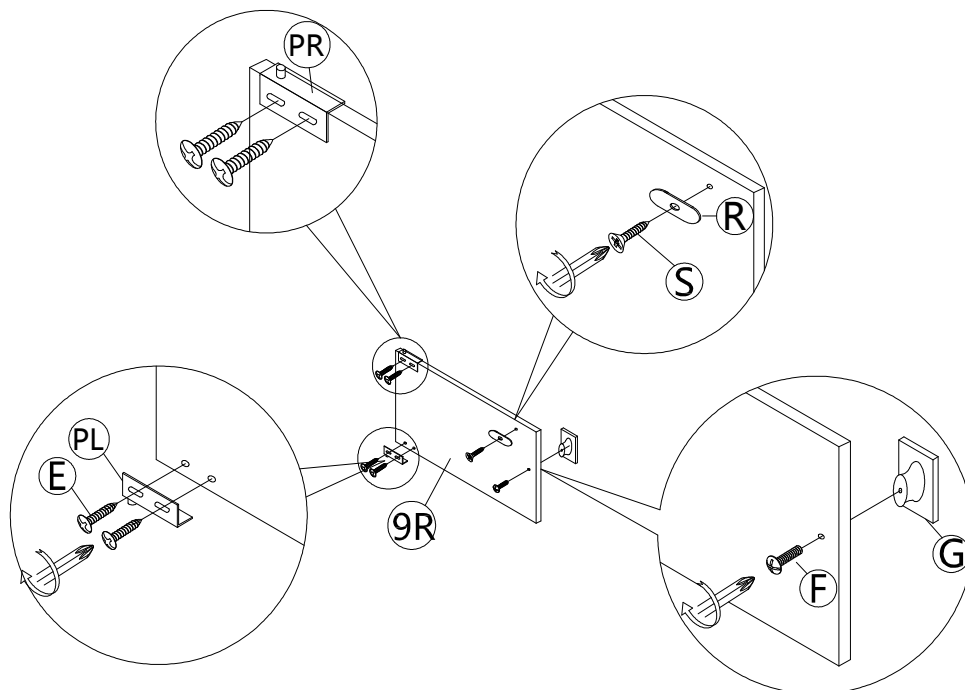
**Figure 14**

Attach Hinges (**PL/PR**) to Top Left Door Panel (**9L**) with Screws (**E**).

Attach Iron Plate (**R**) to Top Left Door Panel (**9L**) with Screw (**S**).

Attach Knob (**G**) to Top Left Door Panel (**9L**) with Bolt (**F**).

Tighten Bolt (**F**) and Screws (**E/S**) with Phillips screwdriver (not included).



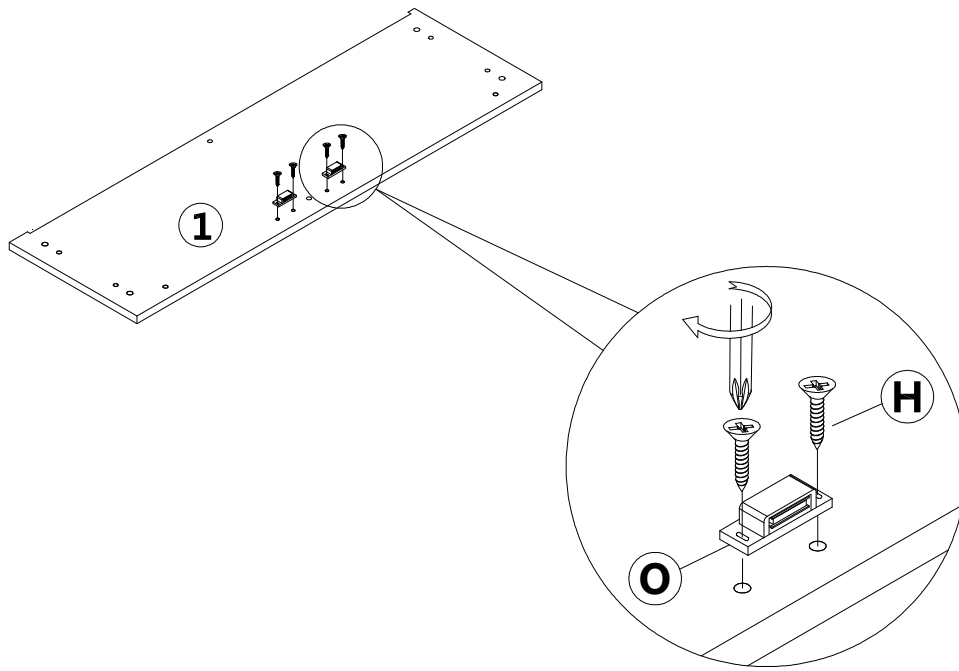
**Figure 15**

Attach Hinges (**PL/PR**) to Top Right Door Panel (**9R**) with Screws (**E**).

Attach Iron Plate (**R**) to Top Right Door Panel (**9R**) with Screw (**S**).

Attach Knob (**G**) to Top Right Door Panel (**9R**) with Bolt (**F**).

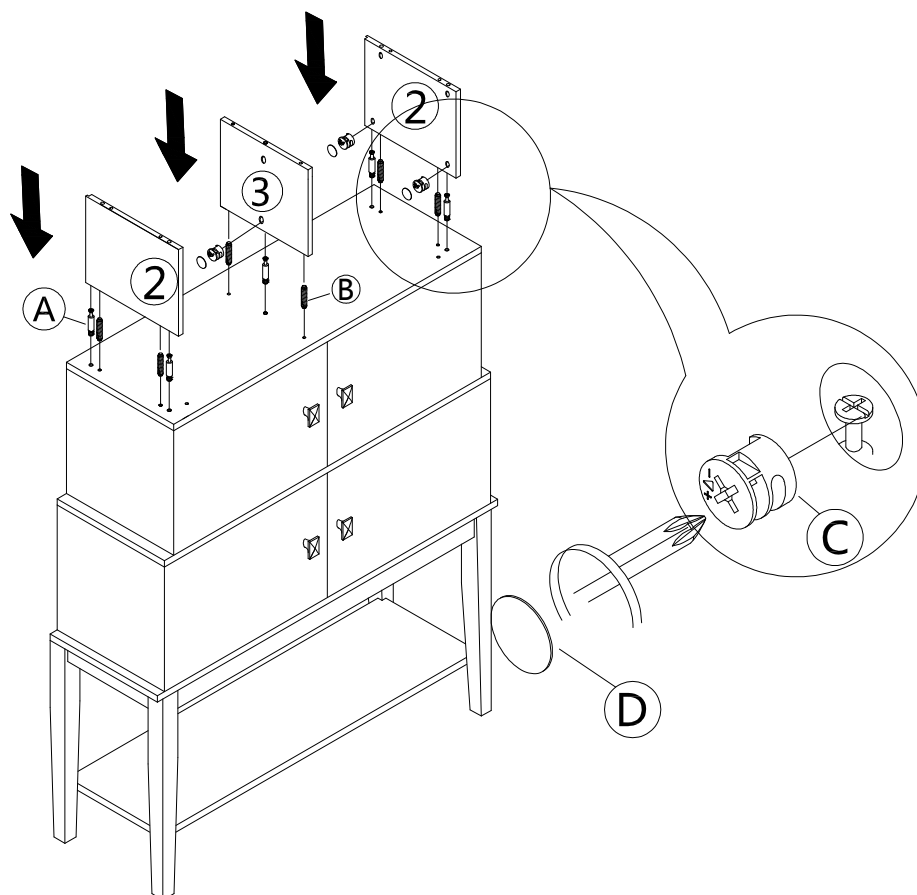
Tighten Bolt (**F**) and Screws (**E/S**) with Phillips screwdriver (not included).



Attach Magnets **(O)** to Top Panel **(1)** with Screws **(H)**.

Tighten Screws **(H)** with Phillips screwdriver (not included)

Figure 16



Insert Cam Locks **(C)** into Top Side Panels **(2)** and Top Vertical Panel **(3)**.

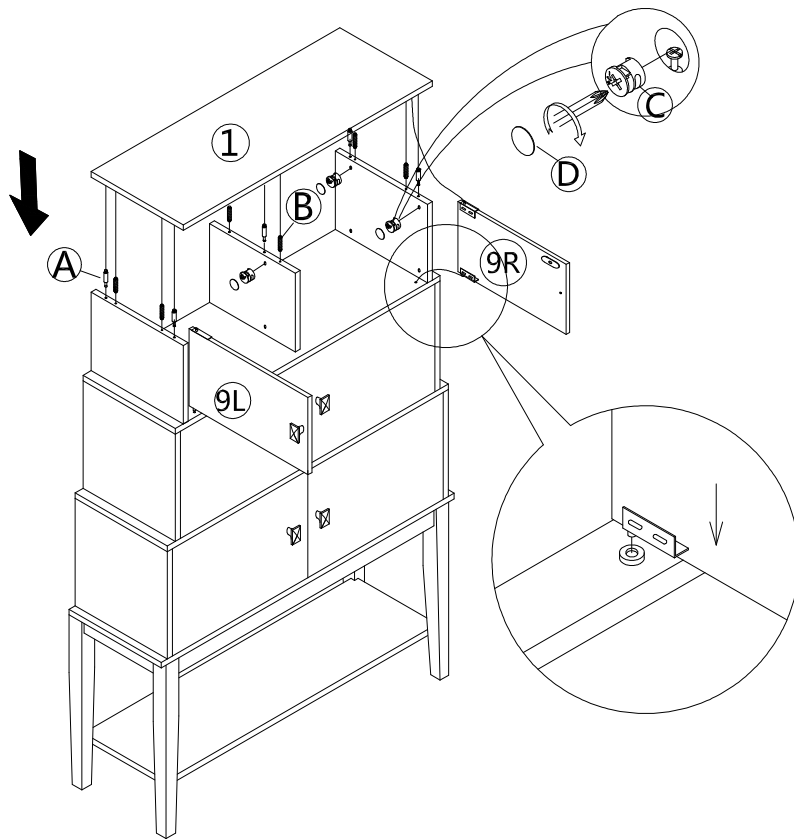
Screw Cam Bolts **(A)** into threaded holes on pre-assembled unit from Figure 13.

Attach Top Side Panels **(2)** and Top Vertical Panel **(3)** to pre-assembled unit from Figure 13 by inserting Cam Bolts **(A)** and Wood Dowels **(B)** into corresponding holes until all panels meet.

Tighten Cam Bolts **(A)** by rotating Cam Locks **(C)** clockwise using Phillips screwdriver (not included).

Cover Cam Lock Holes with Covers **(D)**.

Figure 17



**Figure 18**

Insert Cam Locks **(C)** into corresponding holes on pre-assembled unit from figure 17.

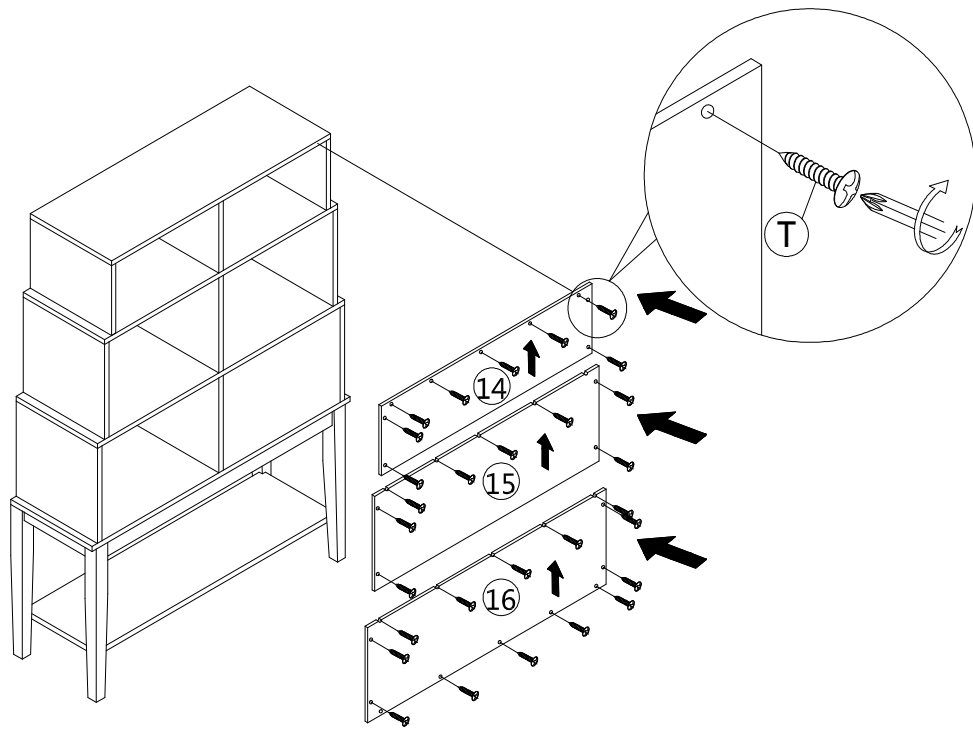
Screw Cam Bolts **(A)** into threaded holes on Top Panel **(1)**.

Attach Top Doors **(9L/9R)** to pre-assembled unit from figure 17 by inserting lower hinges into corresponding holes. Upper hinges will fit in holes on Top Panel **(1)**.

Attach Top Panel **(1)** to pre-assembled unit from Figure 17 by inserting Cam Bolts **(A)** and Wood Dowels **(B)** into corresponding holes until all panels meet.

Tighten Cam Bolts **(A)** by rotating Cam Locks **(C)** clockwise using Phillips screwdriver (not included).

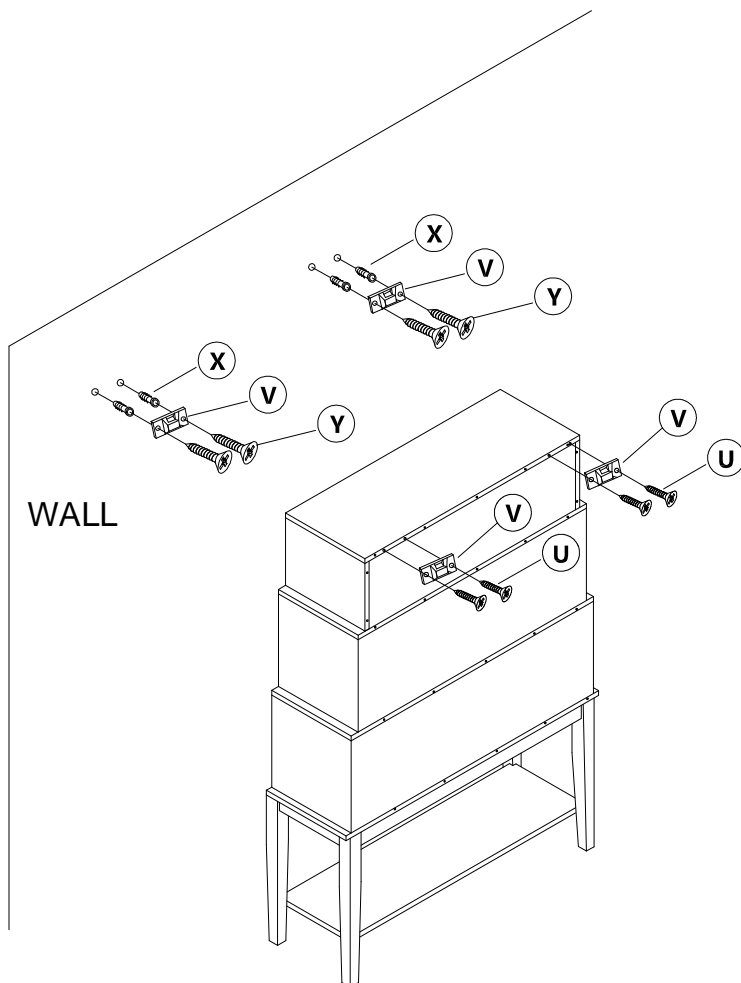
Cover Cam Lock Holes with Covers **(D)**.



**Figure 19**

Attach Back Panels **(14/15/16)** to pre-assembled unit from Figure 18 with Screws **(T)**.

Tighten Screws **(T)** with Phillips screwdriver (not included).



**Figure 20**

Attach Brackets **(V)** to Back Panels **(14/15/16)** using Screws **(U)**.

Mark two desired locations on wall.

Drill two 3/16" holes on wall.

Insert Plastic Anchors **(X)** into the 2 holes on wall, tap with hammer (not included) as needed.

Attach Brackets **(V)** to wall using Screws **(Y)**.

Tighten Screws **(U/Y)** using a Philips screwdriver (not included).



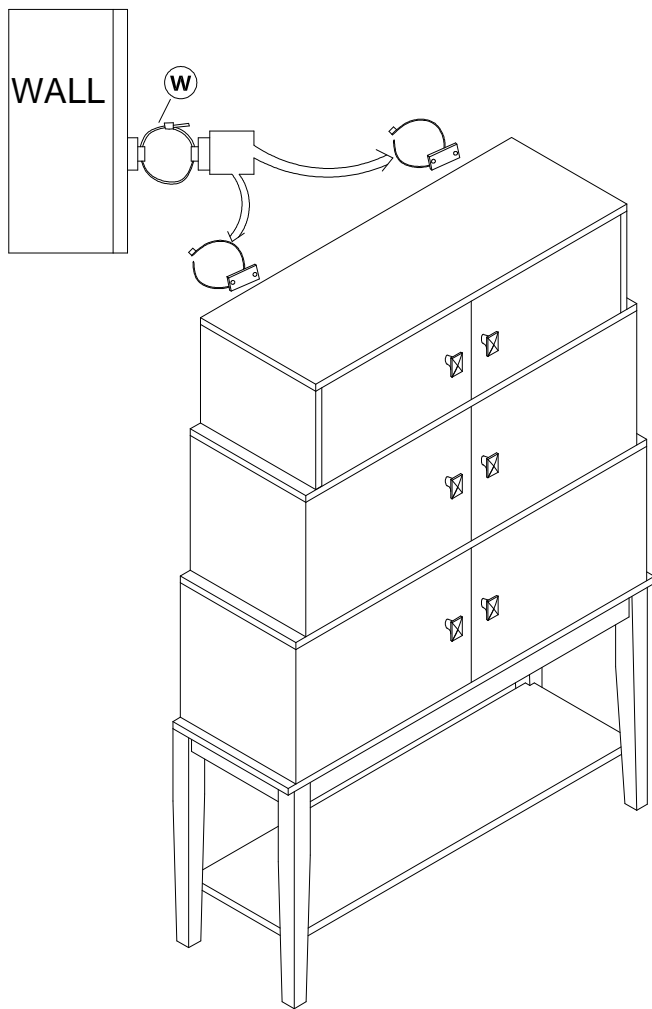
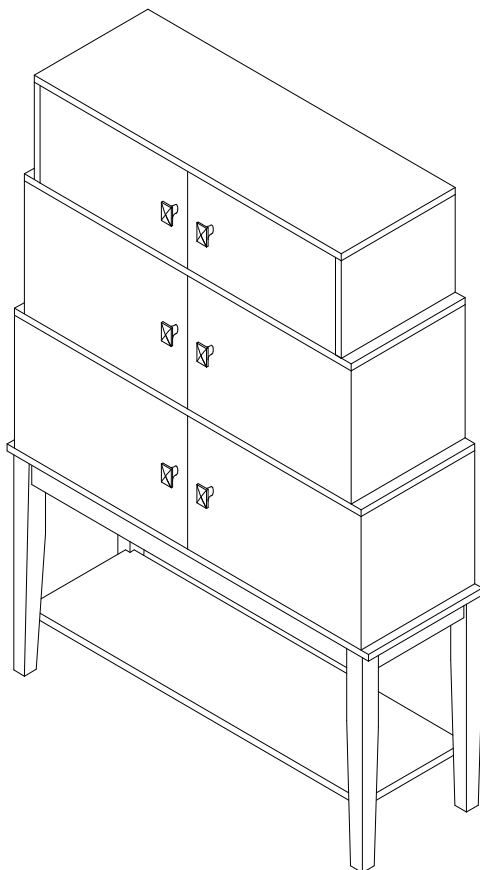


Figure 21

Move this item close to the wall.

Tie Brackets **(V)** together with Plastic Chains **(W)**.

**Anti-tipping hardware must be used for this product to avoid tipping and injury.**



Now your Wyman Tiered Storage Cabinet is ready for use!

# Parts Replacement Form

## Customer Information

Name \_\_\_\_\_

Address \_\_\_\_\_

City/State/Zip Code \_\_\_\_\_

Phone Number \_\_\_\_\_

Please indicate where you purchased this item: Store/Website/Catalog

\_\_\_\_\_

Please indicate color/size/style number:

\_\_\_\_\_

Style No	Parts Letter	Parts Description	Quantity Needed
_____	_____	_____	_____
_____	_____	_____	_____
_____	_____	_____	_____

Please immediately examine this product carefully. Any request for missing parts or damage replacement must be received within 90 days of your receipt of the product. Replacement, if available, will be honored within this time frame. Parts will not be available for items arriving fully assembled. We do not recommend modifying product(s) and we are not responsible for any damages due to product modification(s). If damages or missing parts are not reported within 90 days of your receipt, we are under no obligation to provide parts or replacement merchandise.

For product issues, please contact Southern Enterprises at 800-633-5096 (toll-free) / 972-869-0111 (Dallas), Mon-Fri 9am – 4pm CST, or email us at [service@seidal.com](mailto:service@seidal.com). Please ask for customer service representative for issues involving damages or replacement parts. Please ask for technical assistance representative for any issues with product and assembly/construction.

Please contact the retailer that you purchased from for returns.



**Southern**  
ENTERPRISES

Customer Service: 1-800-633-5096  
[service@seidal.com](mailto:service@seidal.com)

Southern Enterprises, Inc.  
600 Freeport Parkway, Suite 200  
Coppell, Texas 75019