

**HZ102800TX**

**Dowd Cabinet**

**Assembly Instructions**



**Southern**  
ENTERPRISES

For assistance with assembly, contact:  
Southern Enterprises Inc.

Customer Service 1-800-633-5096

[service@seidal.com](mailto:service@seidal.com)

[www.seidal.com](http://www.seidal.com)

PO# :

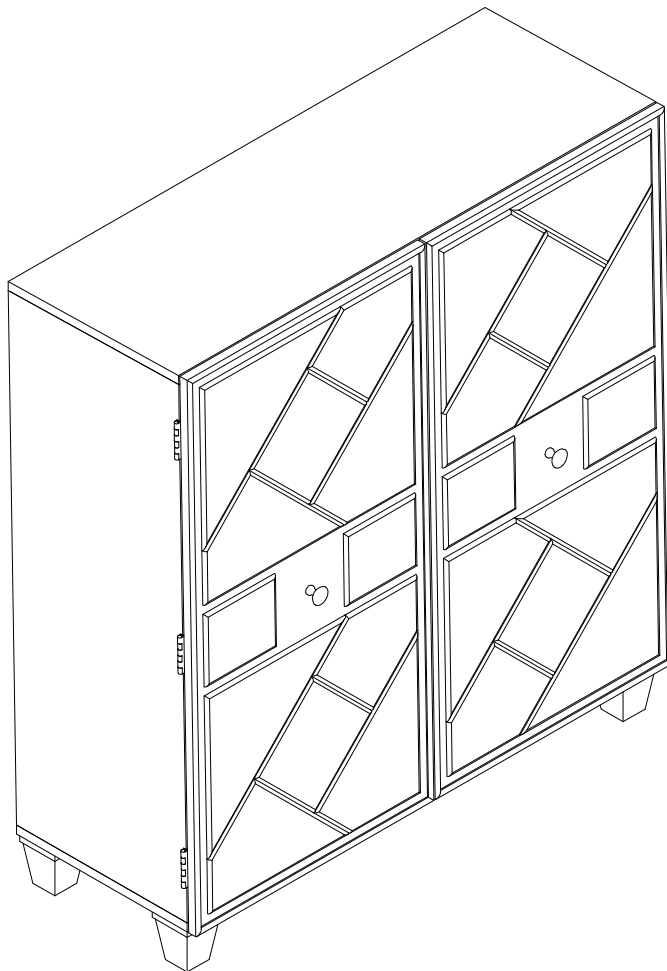



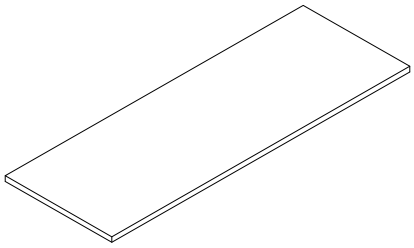
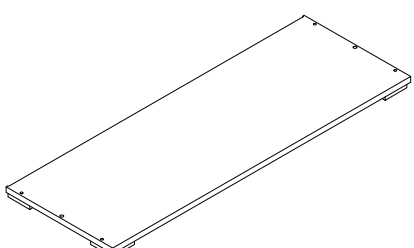
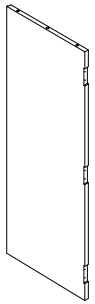
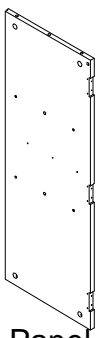
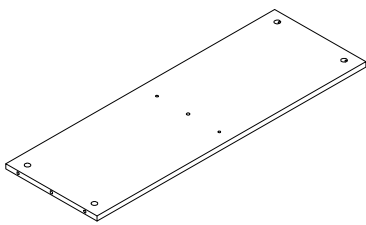
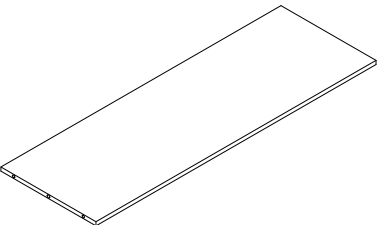
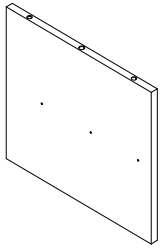
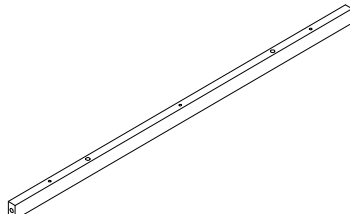
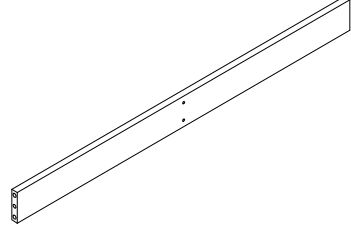
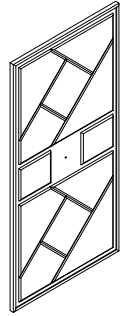
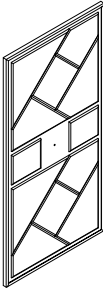
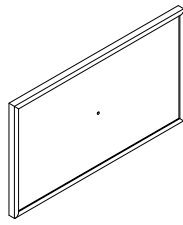

# Dowd Cabinet

## Assembly Instructions

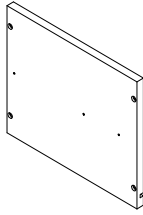
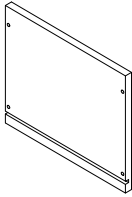
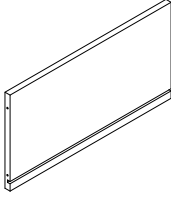
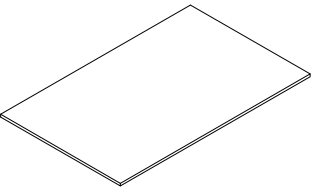
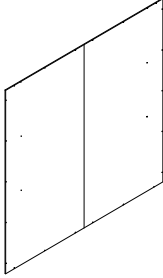
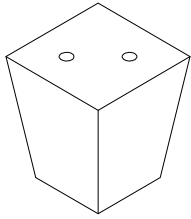
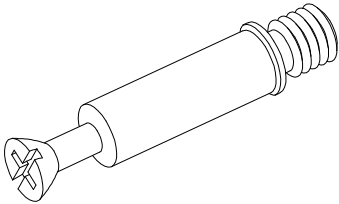
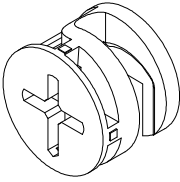
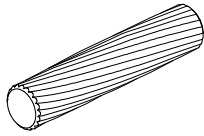
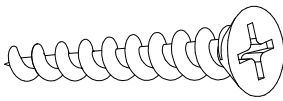
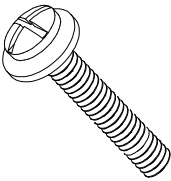
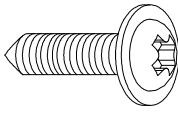
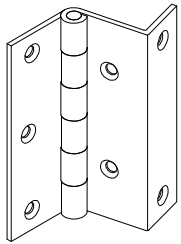
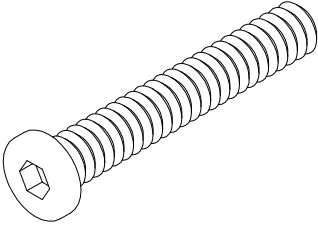
Please check packaging for all parts and hardware before discarding. Unpack and lay parts on clean, padded surface like carpet or blanket. Check that you have all parts indicated. Call customer service if hardware is missing. Before beginning assembly, carefully study the diagrams below and sort your hardware according to the pictures. Using the incorrect hardware will cause damage.

<p>A. Quantity of 1</p>  <p>Top Panel</p>	<p>B. Quantity of 1</p>  <p>Bottom Panel</p>	<p>C. Quantity of 1</p>  <p>Left Side Panel</p>
<p>D. Quantity of 1</p>  <p>Right Side Panel</p>	<p>E. Quantity of 1</p>  <p>Lower Fixed Shelf Panel</p>	<p>F. Quantity of 1</p>  <p>Upper Fixed Shelf Panel</p>
<p>G. Quantity of 1</p>  <p>Middle Vertical Panel</p>	<p>H. Quantity of 1</p>  <p>Front Crosspiece</p>	<p>I. Quantity of 1</p>  <p>Back Crosspiece</p>
<p>J. Quantity of 1</p>  <p>Left Door</p>	<p>K. Quantity of 1</p>  <p>Right Door</p>	<p>L. Quantity of 2</p>  <p>Drawer Front Panel</p>

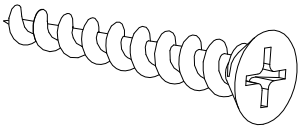
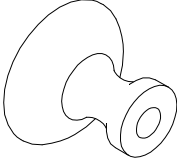
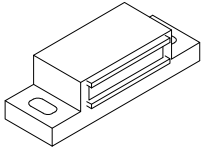
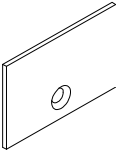
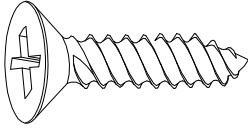
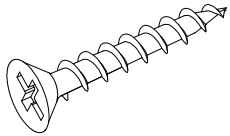
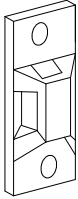
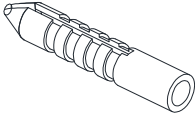
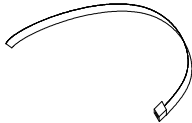
<p>M. Quantity of 2</p>  <p>Drawer Left Panel</p>	<p>N. Quantity of 2</p>  <p>Drawer Right Panel</p>	<p>O. Quantity of 2</p>  <p>Drawer Right Panel</p>
<p>P. Quantity of 2</p>  <p>Drawer Bottom Panel</p>	<p>Q. Quantity of 1</p>  <p>Back Panel</p>	<p>R. Quantity of 4</p>  <p>Leg</p>
<p>1. Quantity of 22</p>  <p>Cam Bolt</p>	<p>2. Quantity of 22</p>  <p>Cam Lock</p>	<p>3. Quantity of 18</p>  <p>Wood Dowel <math>\varnothing 8 \times 30\text{mm}</math></p>
<p>4. Quantity of 56</p>  <p>Flat Head Screw <math>\varnothing 1/8" \times 1/2"</math></p>	<p>5. Quantity of 4</p>  <p>Bolt for Handle <math>\varnothing 5/32" \times 3/4"</math></p>	<p>6. Quantity of 28</p>  <p>Round Head Screw <math>\varnothing 1/8" \times 5/8" \text{L}</math> (for Back Panel and Magnet)</p>
<p>7. Quantity of 6</p>  <p>Hinge</p>	<p>8. Quantity of 8</p>  <p>Bolt <math>\varnothing 1/4" \times 2-3/4" \text{L}</math></p>	<p>9. Quantity of 1</p>  <p>Allen Wrench</p>

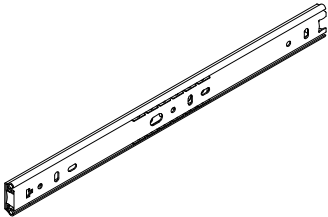
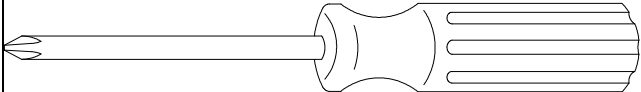
<p>10. <span style="float: right;">Quantity of 21</span></p>  <p>Screw <math>\varnothing 1/8"</math>x1"</p>	<p>11. <span style="float: right;">Quantity of 4</span></p>  <p>Handle</p>	<p>12. <span style="float: right;">Quantity of 2</span></p>  <p>Magnet</p>
<p>13. <span style="float: right;">Quantity of 2</span></p>  <p>Magnet Plate</p>	<p>14. <span style="float: right;">Quantity of 4</span></p>  <p>Screw <math>\varnothing 1/8"</math>x5/8"</p>	<p>15. <span style="float: right;">Quantity of 4</span></p>  <p>Screw <math>\varnothing 1/8"</math> x 1-5/8"L</p>
<p>16. <span style="float: right;">Quantity of 4</span></p>  <p>Bracket</p>	<p>17. <span style="float: right;">Quantity of 4</span></p>  <p>Anchor</p>	<p>18. <span style="float: right;">Quantity of 2</span></p>  <p>Plastic Strap</p>
<p>19. <span style="float: right;">Quantity of 8</span></p>  <p>Cover</p>	<p>20. <span style="float: right;">Quantity of 4</span></p>  <p>Drawer Slide</p>	
<p><b>Care and Cleaning Instructions:</b>          Before using, wipe with a clean, dry cloth. Periodically apply furniture wax to renew the finish. Avoid rubbing or scratching the surface with rough or abrasive objects.</p>		<p>For replacement parts or questions, please call customer service at 1-800-633-5096.</p>
<p><b>Assembly Tool Required No.2 Phillips Screwdriver (Not Included)</b></p>		

# Dowd Cabinet Assembly Instructions

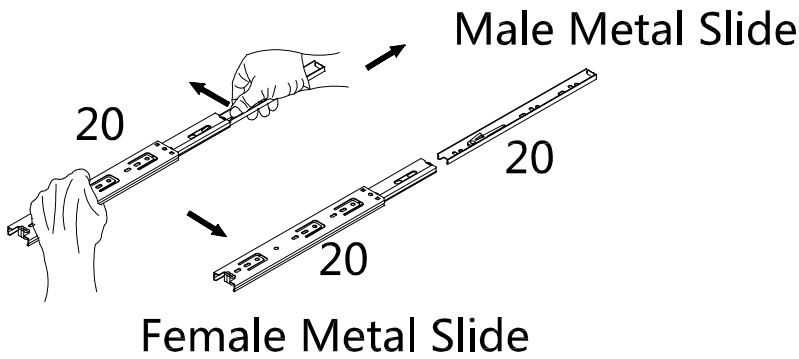

Please separate Drawer Slides **(20)** into male and female components as shown.

**Note:** There is a lever located on the male slide. Push the lever to the either side while pulling in order to detach the male slide from the female slide.

**Figure 1**

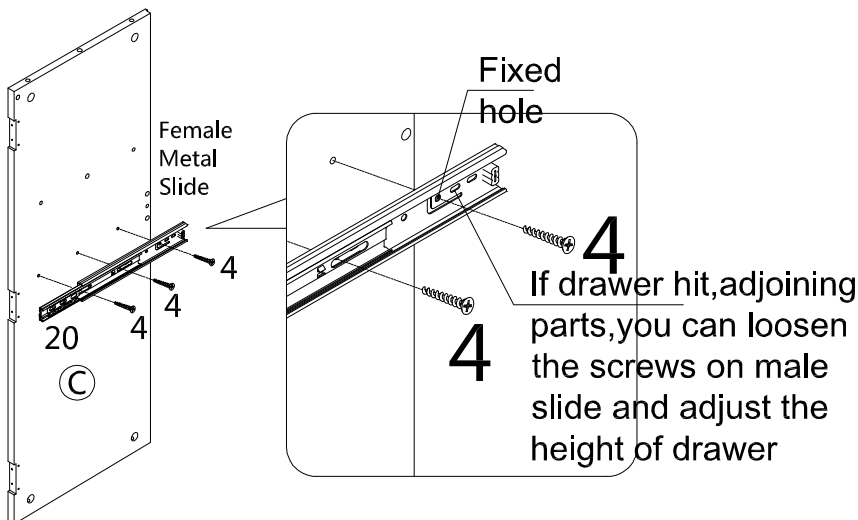

Screw with fingers to help align screws before using screwdriver.

Attach Female Drawer Slide **(20)** components to Left Side Panel **(C)** using Flat Head Screws **(4)**.

Tighten Flat Head Screws **(4)** with Phillips screwdriver.

**Note:** When attaching the female slides, make sure to insert wood screws through the first opening starting from the front, then align the openings to the pre-drilled holes on the panels.

**Figure 2**

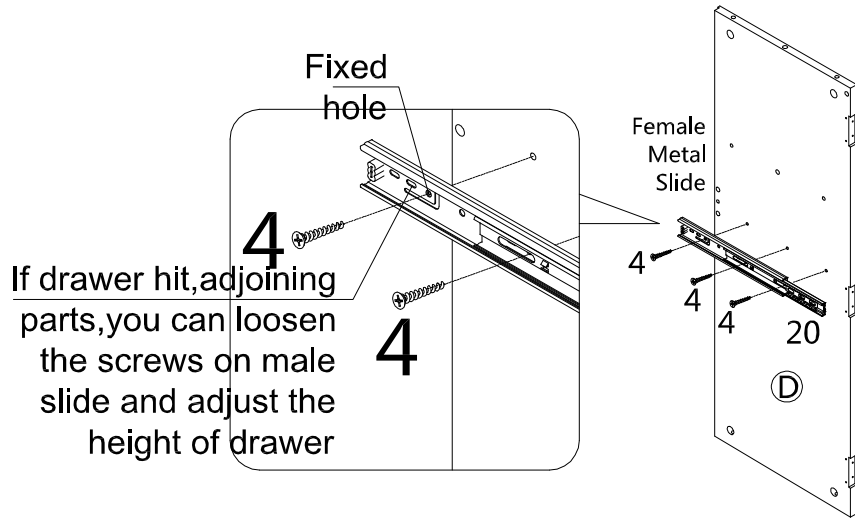

Attach Female Drawer Slide (20) to Right Side Panel (D) using Flat Head Screws (4).

Tighten Flat Head Screws (4) with Phillips screwdriver.

Figure 3

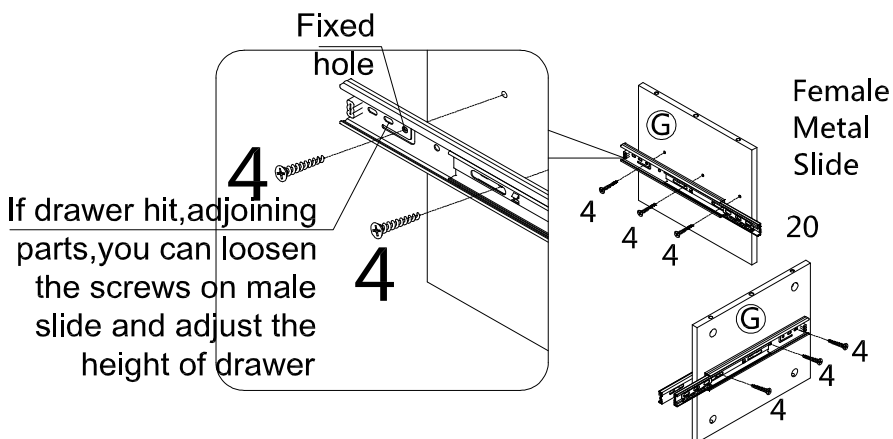

Attach two Female Drawer Slides (20) to Middle Vertical Panel (G) using Flat Head Screws (4).

Tighten Flat Head Screws (4) with Phillips screwdriver.

Figure 4

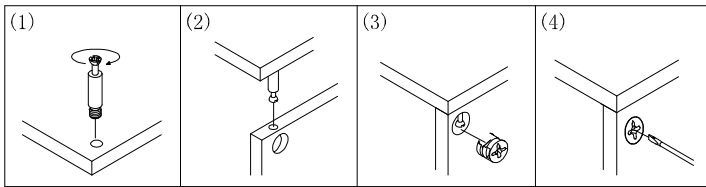

"Please do not over tighten cambolts. Please stop when you feel tight"

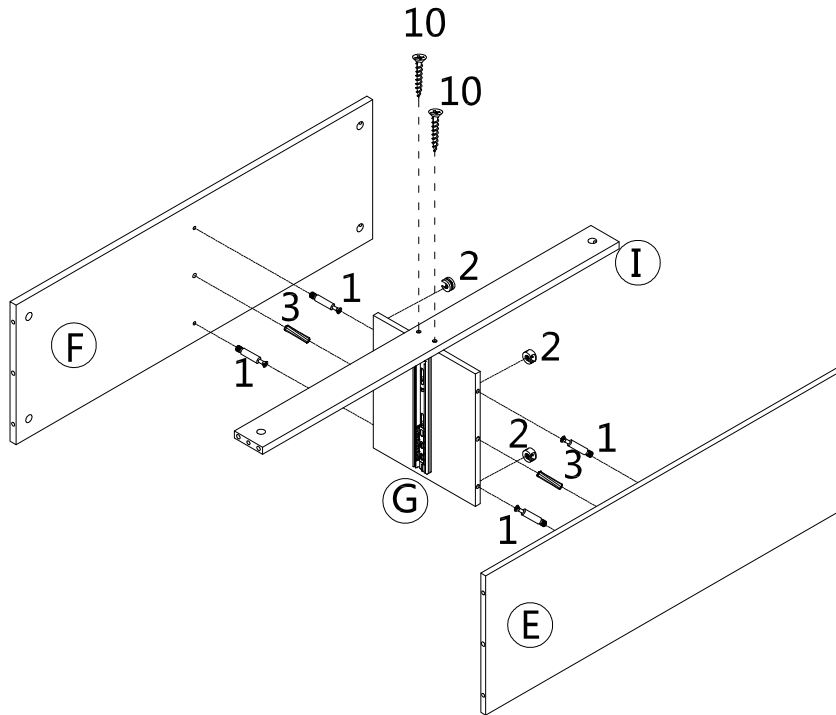

Figure 5

Screw with fingers to help align cam bolts before using screwdriver.

Insert Cam Locks (2) into corresponding holes on Middle Vertical Panel (G).

Screw Cam Bolts (1) and insert Wood Dowels (3) into corresponding holes on Lower Fixed Shelf Panel (E) and Upper Fixed Shelf Panel (F).

Attach Lower Fixed Shelf Panel (E) and Upper Fixed Shelf Panel (F) to Middle Vertical Panel (G) by inserting Wood Dowels (3) and Cam Bolts (1) into corresponding holes until panels meet.

Tighten by rotating Cam Locks (2) clockwise with Phillips screwdriver.

Attach Back Crosspiece (I) to Middle Vertical Panel (G) using Screws (10). Tighten Screws (10) with Phillips screwdriver.

**Notice: Make sure that all finished edges are facing towards the front of the unit.**

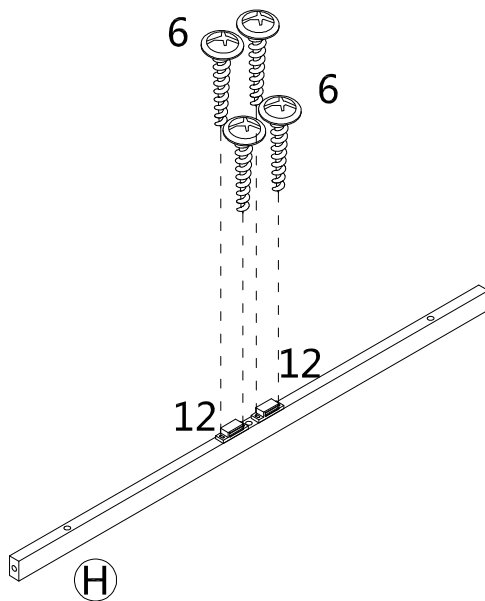
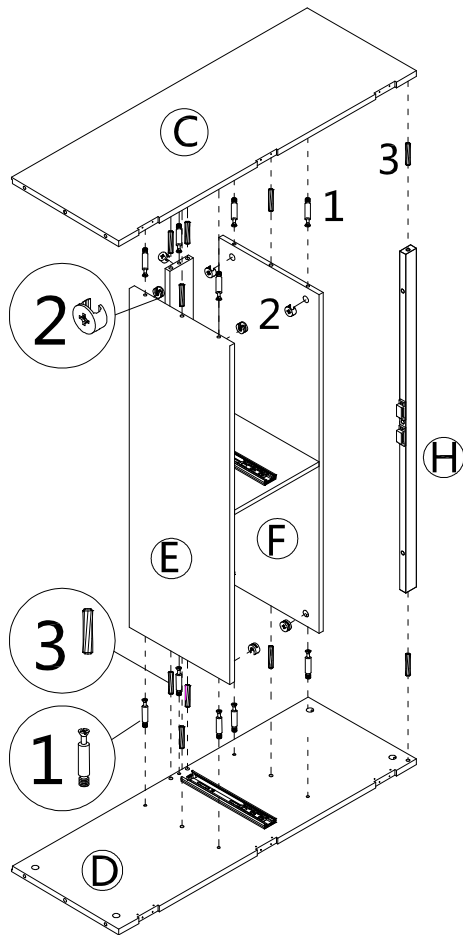

Figure 6

Attach Magnets (12) to Front Crosspiece (H) using Round Head Screw (6) as shown.

Tighten Round Head Screw (6) with Phillips screwdriver.



**Figure 7**

Insert Cam Locks **(2)** into corresponding holes on assembled unit from Figure 5

Screw Cam Bolts **(1)** and insert Wood Dowels **(3)** into corresponding holes on Left Side Panel **(C)** and Right Side Panel **(D)**.

Attach Left Side Panel **(C)**, Right Side Panel **(D)** and Front Crosspiece **(H)** to assembled unit from Figure 6 by inserting Wood Dowels **(3)** and Cam Bolts **(1)** into corresponding holes until Left Side Panel **(C)**, Right Side Panel **(D)** and Front Crosspiece **(H)** and assembled unit from Figure 5 meet.

Tighten by rotating Cam Locks **(2)** clockwise with Phillips screwdriver.

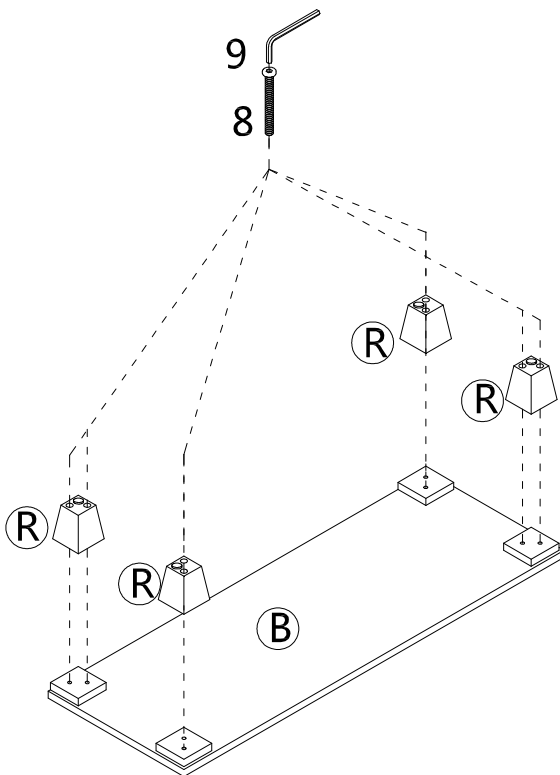
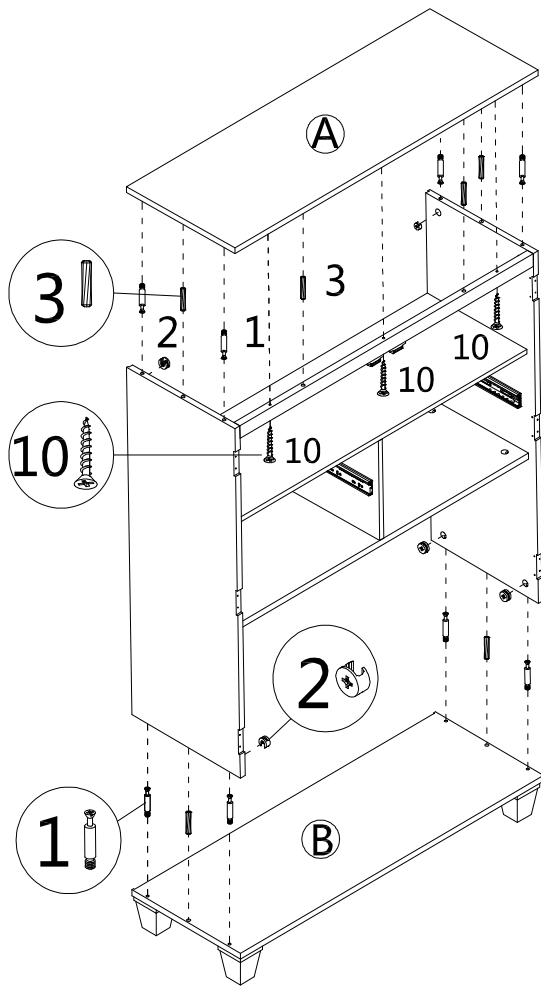

**Figure 8**

Attach Legs **(R)** to Bottom Panel **(B)** using Bolt **(8)** as shown.

Tighten Bolt **(8)** with Allen Wrench **(8)**.





**Figure 9**

Insert Cam Locks **(2)** into corresponding holes on assembled unit from Figure 7.

Screw Cam Bolts **(1)** and insert Wood Dowels **(3)** into corresponding holes on Top Panel **(A)** and Bottom Panel **(B)**.

Attach Top Panel **(A)** and Bottom Panel **(B)** to assembled unit from Figure 7 by inserting Wood Dowels **(3)** and Cam Bolts **(1)** into corresponding holes until Top Panel **(A)** and Bottom Panel **(B)** and assembled unit from Figure 7 meet.

Tighten by rotating Cam Locks **(2)** clockwise with Phillips screwdriver.

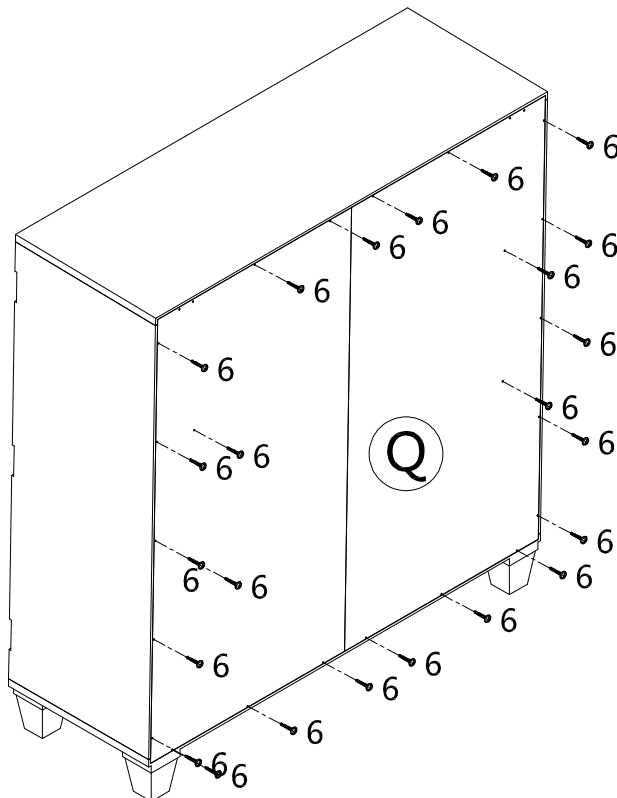

**Figure 10**

Attach Back Panel **(Q)** to backside of the assembled of the unit with Round Head Screws **(6)**.

Tighten Screws **(6)** with a Phillips screwdriver.

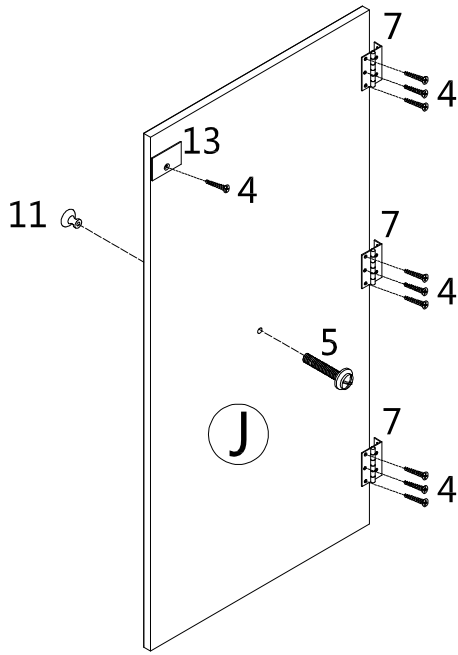

Attach the Metal Plate **(13)** on the inner inside of the Left Door **(J)** using Flat Head Screws **(4)**

Attach the Hinges **(7)** to the Door **(J)** using Flat Head Screws **(4)**

Tighten Flat Head Screws **(4)** with Phillips screwdriver.

Attach the Door Handle **(11)** on the door using Bolt for Handle **(5)**.

Tighten Bolt **(5)** with Phillips screwdriver

**Figure 11**

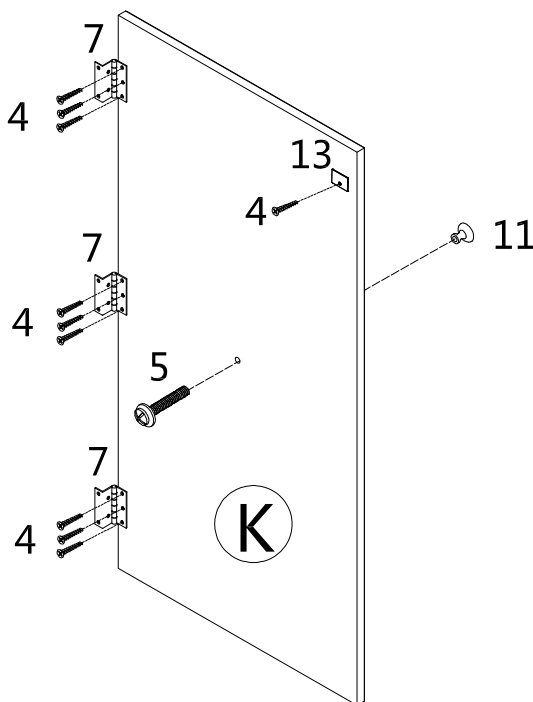

Attach the Metal Plate **(13)** to the inner inside of the Right Door **(K)** using Flat Head Screws **(4)**

Attach the Hinges **(7)** to the Door **(K)** using Flat Head Screws **(4)**

Tighten Flat Head Screws **(4)** with Phillips screwdriver.

Attach the Door Handle **(11)** to the door using Bolt for Handle **(5)**.

Tighten Bolt **(5)** with Phillips screwdriver

**Figure 12**

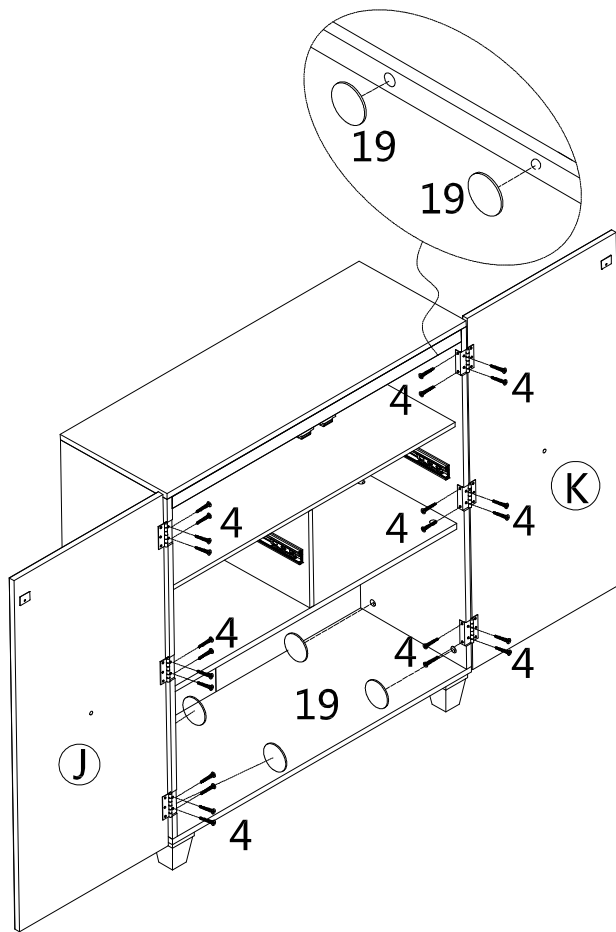
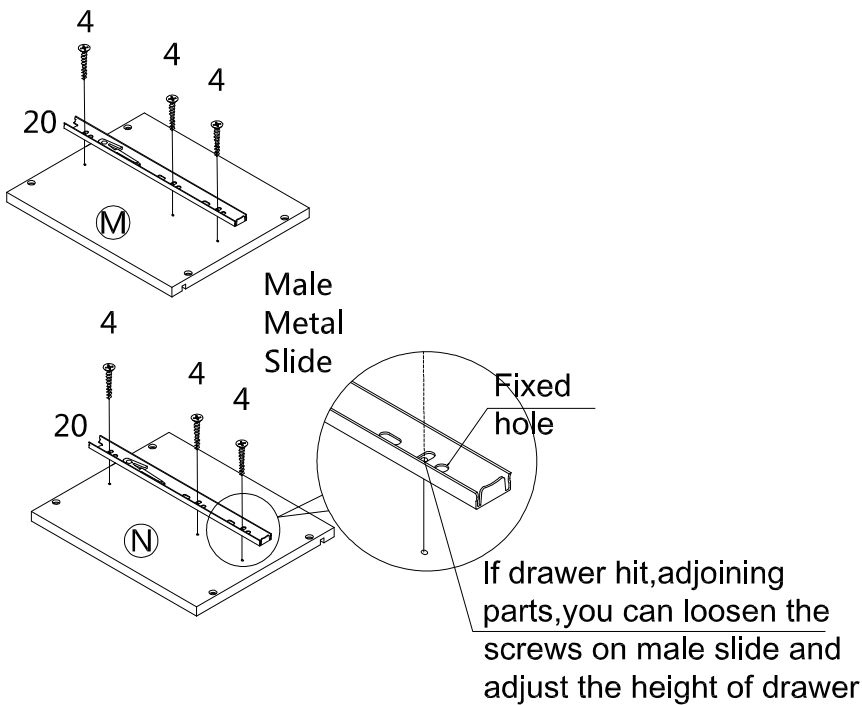

**Figure 13**

Attach Doors (**J/K**) to the unit using Flat Head Screws (**4**).

Tighten Flat Head Screws (**4**) with Phillips screwdriver.

Cover Cam Locks with Cover (**19**) as shown.



**Figure 14**

Attach Male Drawer Slide (**20**) to Drawer Side Panels (**M/N**) using Flat Head Screws (**4**).

Tighten Flat Head Screws (**4**) with Phillips screwdriver.

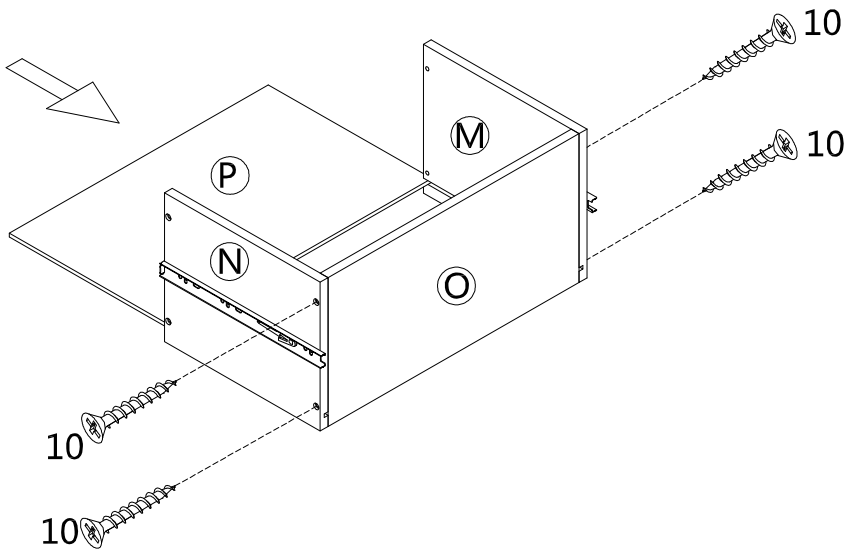
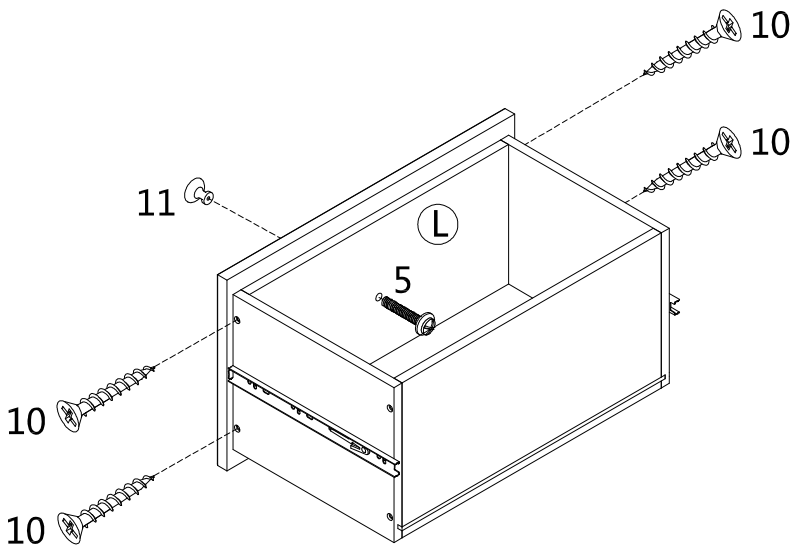

**Figure 15**

Attach Drawer Back Panel **(O)** to Drawer Side Panels **(M/N)** using Screws **(10)**.

Tighten Screws **(10)** with Phillips screwdriver.

Insert Drawer Bottom Panel **(P)** into the grooves of assembled unit.



**Figure 16**

Attach Drawer Front Panel **(L)** to assembled unit using Screws **(10)**.

Tighten Screws **(10)** with Phillips screwdriver.

Attach Handle **(11)** to Drawer Front Panel **(L)** using Bolt for Handle **(5)**.

Tighten Bolt for Handle **(5)** with Phillips screwdriver.

Repeat Figures 14-16 to assemble the other drawer.

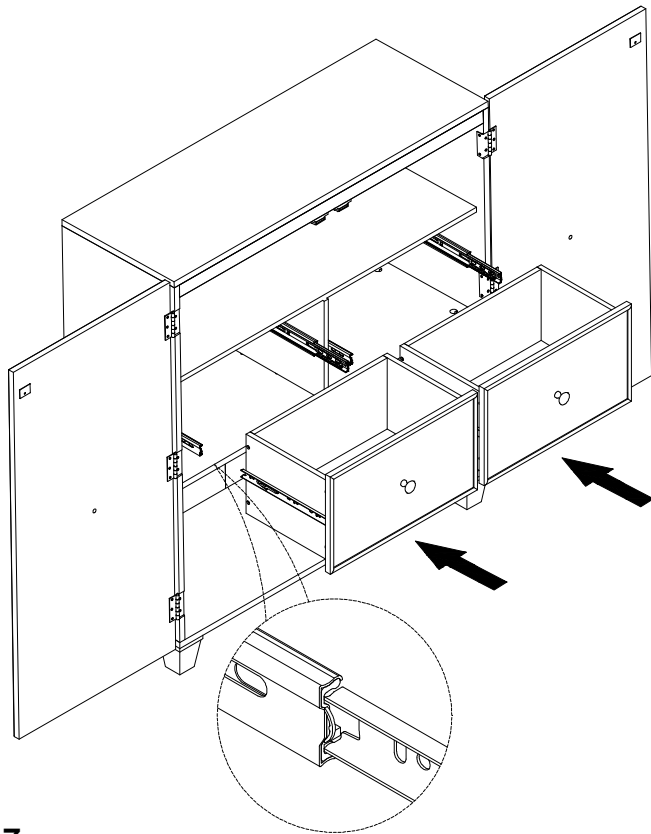

**Figure 17**

Insert drawers into assembled unit.

Make sure drawer's male ball bearing slides are carefully inserted into side panel's female ball bearing slide. Make sure ball bearing slides glide smoothly in and out.

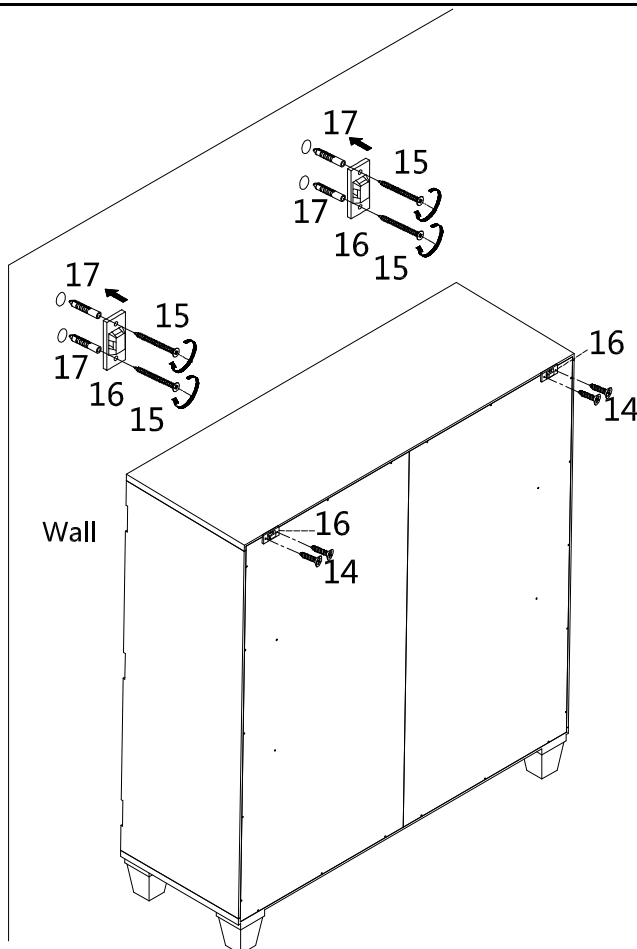

**Figure 18**

Attach Brackets (16) to back panel using Screws (14).

Tighten Screws (14) using Philips screwdriver.

Mark two desired locations on wall and drill two 3/16" holes for each Bracket (16) the same distance as the brackets on the back of the unit.

Insert Plastic Anchors (17) into two holes for each Bracket (16) on wall as shown. Use a hammer to insert plastic anchors until they are flush with wall.

Then, attach Brackets (16) onto wall using Screws (15).

Tighten Screws (15) using Philips screwdriver.

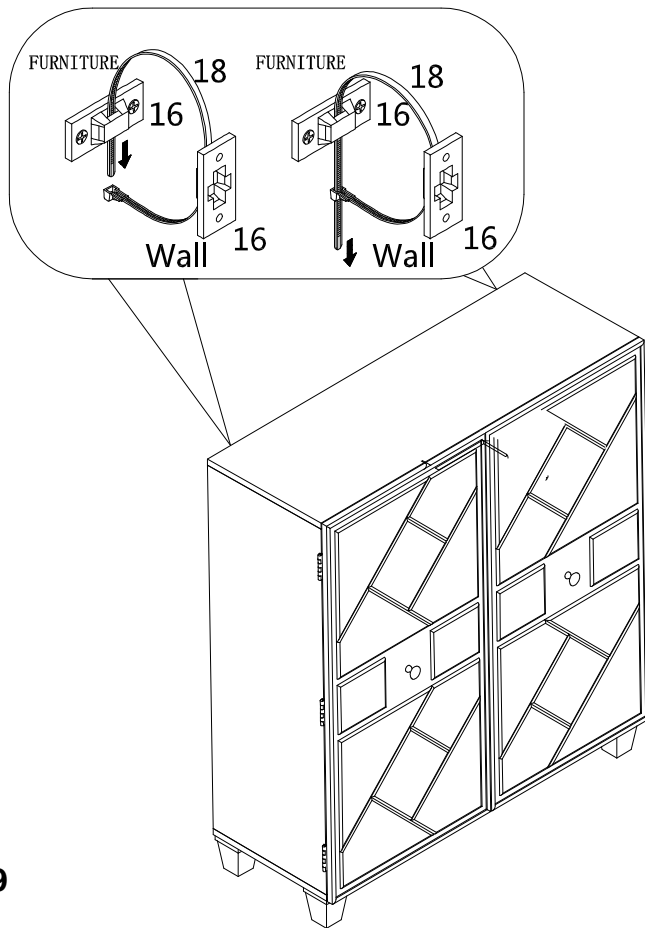

Figure 19

Move this item close to the wall Brackets (16) and tie in all Brackets (16) together with Plastic Straps (18) as shown in diagram.

**Anti-tipping hardware must be used for this product to avoid tipping and injury.**

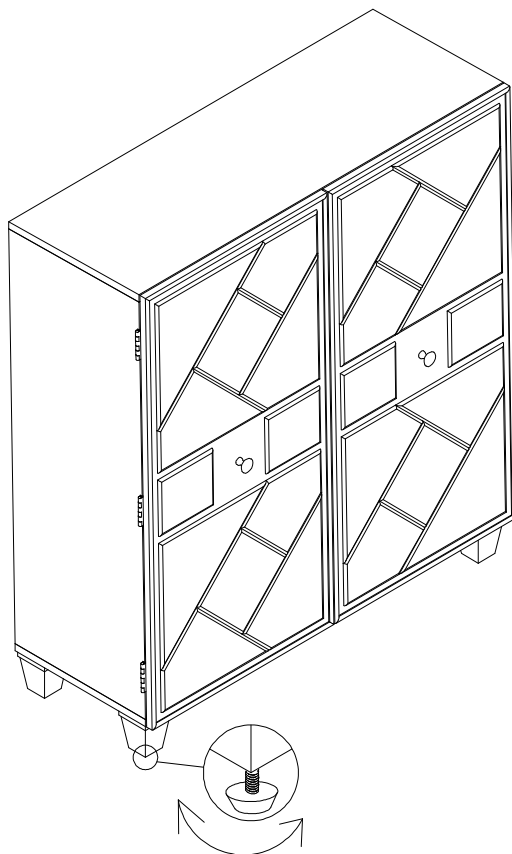

Figure 20

Tip: If the Cabinet is not level, please adjust the Leg's leveler by hand as shown.

Now your Dowd Cabinet is ready for use.

# Parts Replacement Form

## Customer Information

Name \_\_\_\_\_

Address \_\_\_\_\_

City/State/Zip Code \_\_\_\_\_

Phone Number \_\_\_\_\_

Please indicate where you purchased this item: Store/Website/Catalog

\_\_\_\_\_

Please indicate color/size/style number:

\_\_\_\_\_

Style No	Parts Letter	Parts Description	Quantity Needed
_____	_____	_____	_____
_____	_____	_____	_____
_____	_____	_____	_____

Please immediately examine this product carefully. Any request for missing parts or damage replacement must be received within 90 days of your receipt of the product. Replacement, if available, will be honored within this time frame. Parts will not be available for items arriving fully assembled. We do not recommend modifying product(s) and we are not responsible for any damages due to product modification(s). If damages or missing parts are not reported within 90 days of your receipt, we are under no obligation to provide parts or replacement merchandise.

For product issues, please contact Southern Enterprises at 800-633-5096 (toll-free) / 972-869-0111 (Dallas) Mon-Fri 9am – 4pm CST, or email us at [service@seidal.com](mailto:service@seidal.com). Please ask for customer service representative for issues involving damages or replacement parts. Please ask for technical assistance representative for any issues with product and assembly/construction.

Please contact the retailer that you purchased from for returns.



**Southern**  
ENTERPRISES

Customer Service 1-800-633-5096

[service@seidal.com](mailto:service@seidal.com)

Southern Enterprises, Inc.

600 Freeport Parkway, Suite 200

Coppell, Texas 75019