

CK045000TX
Ryecroft Cocktail Trunk
Assembly Instructions



Southern
ENTERPRISES

For assistance with assembly, contact:
Southern Enterprises, Inc.
Customer Service: 1-800-633-5096
service@seidal.com
www.seifurniturestore.com

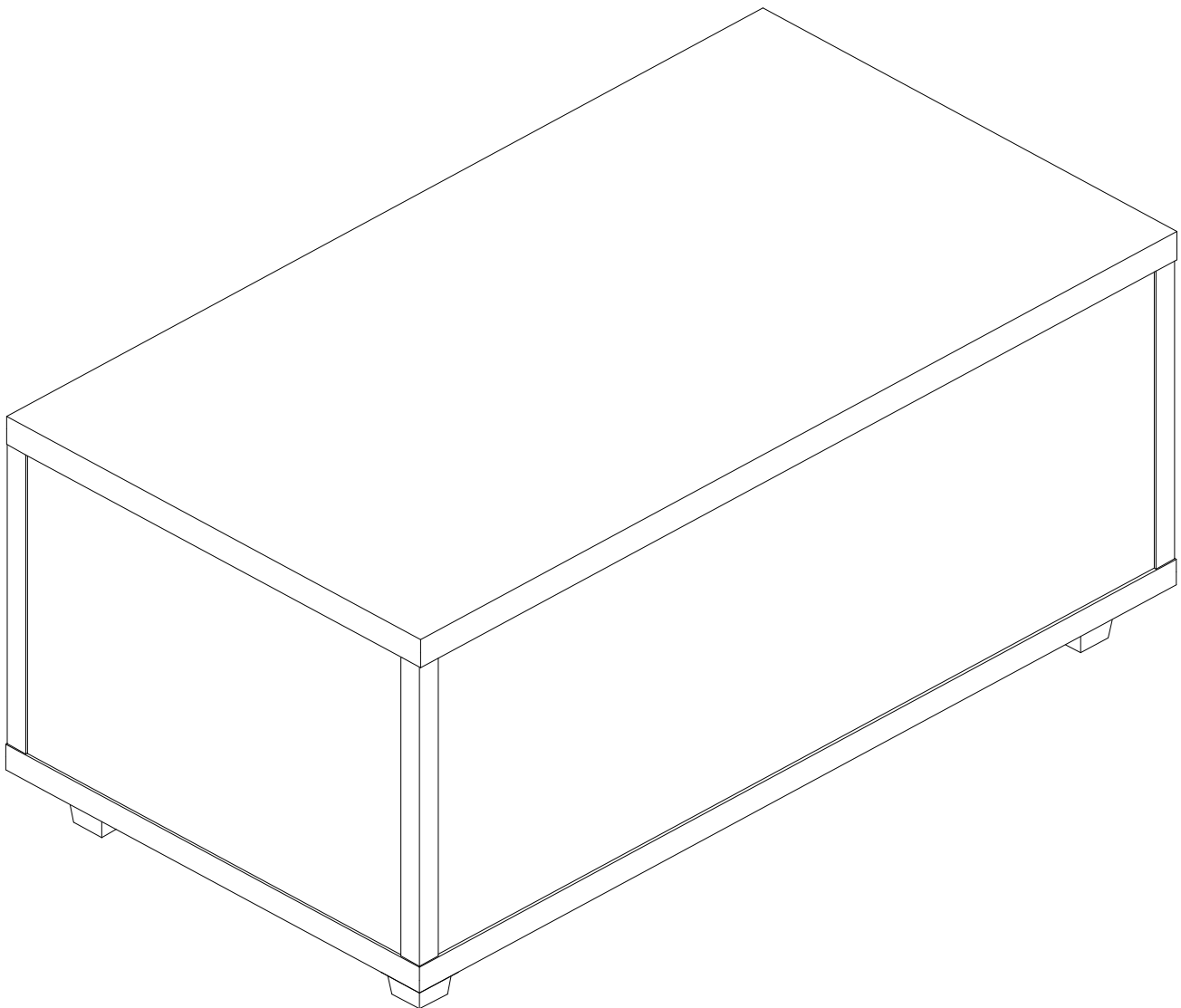

PO:



Ryecroft Cocktail Trunk

Parts List

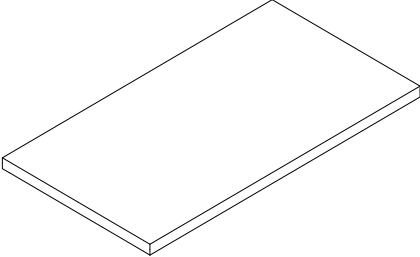
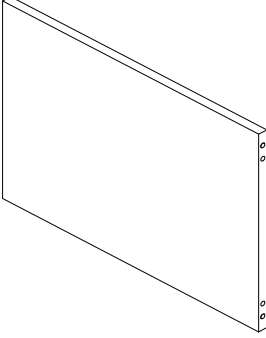
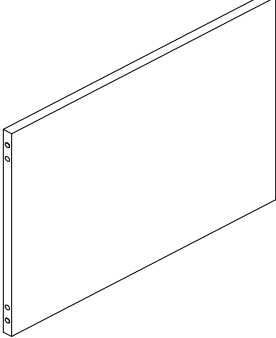
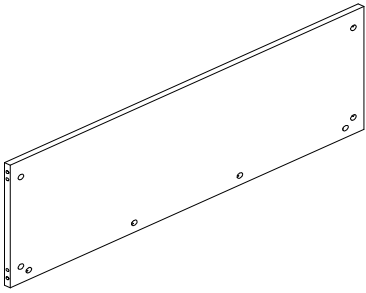
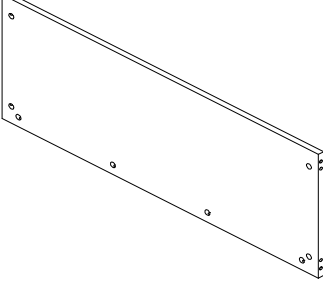
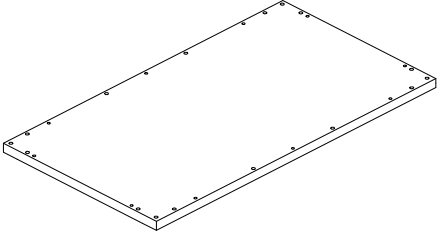
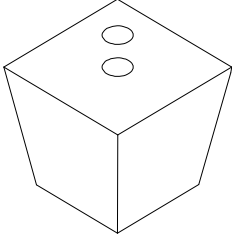
Please check packaging for all parts and hardware before discarding. Unpack and lay parts on clean, padded surface like carpet or a blanket. Check that you have all parts indicated. Call customer service if any hardware is missing. Before beginning assembly, carefully study the diagrams below and sort your hardware according to the pictures. Using the incorrect hardware will cause damage.

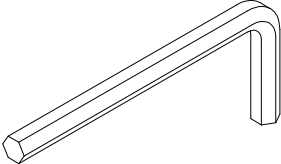
<p>A. Quantity of 1</p>  <p>Top Panel</p>	<p>B. Quantity of 1</p>  <p>Left Side Panel</p>	<p>C. Quantity of 1</p>  <p>Right Side Panel</p>
<p>D. Quantity of 1</p>  <p>Front Panel</p>	<p>E. Quantity of 1</p>  <p>Back Panel</p>	<p>F. Quantity of 1</p>  <p>Bottom Panel</p>
<p>G. Quantity of 4</p>  <p>Foot</p>	<p>H. Quantity of 4</p>  <p>Post</p>	<p>I. Quantity of 1</p>  <p>Allen Wrench</p>

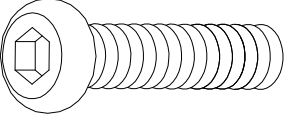
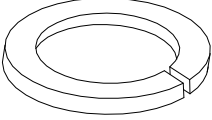
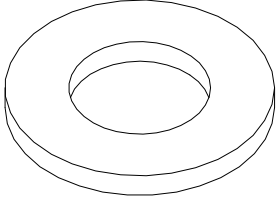
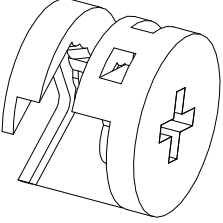
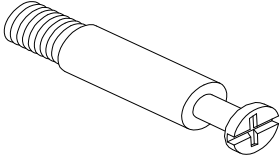
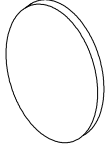
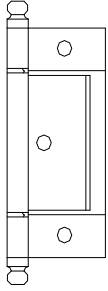
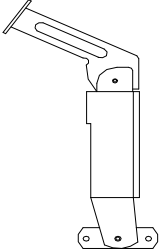
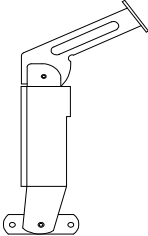
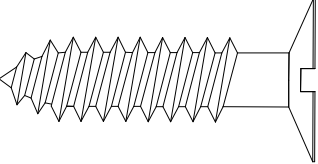
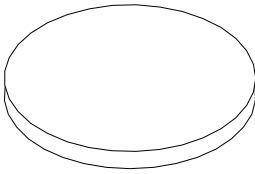
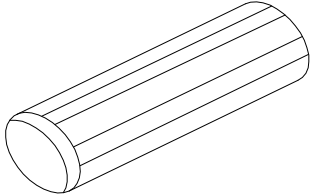
<p>2 Quantity of 4</p>  <p>Bolt \emptyset 5/16" X 2" L</p>	<p>3 Quantity of 4</p>  <p>Spring Washer</p>	<p>4 Quantity of 4</p>  <p>Flat Washer</p>
<p>5 Quantity of 28</p>  <p>Cam Lock</p>	<p>6 Quantity of 28</p>  <p>Cam Bolt</p>	<p>7 Quantity of 28</p>  <p>Sticker Cover</p>
<p>8 Quantity of 3</p>  <p>Folded Hinge</p>	<p>9 Quantity of 1</p>  <p>Right Lid Support</p>	<p>10 Quantity of 1</p>  <p>Left Lid Support</p>
<p>11 Quantity of 26</p>  <p>Screw \emptyset 1/8" X 5/8" L</p>	<p>12 Quantity of 3</p>  <p>EVA Pad</p>	<p>13 Quantity of 30</p>  <p>Wood Dowel</p>

Care and Cleaning Instructions:
 Before using, wipe with a clean, dry cloth. Avoid rubbing or scratching the surface with rough or abrasive objects.

For replacement parts or questions, please call SEI customer service at 1-800-633-5096.

Assembly Tool Required:
 No.2 Phillips Screwdriver (Not Included)

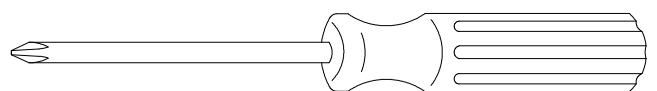

Ryecroft Cocktail Trunk Assembly Instructions

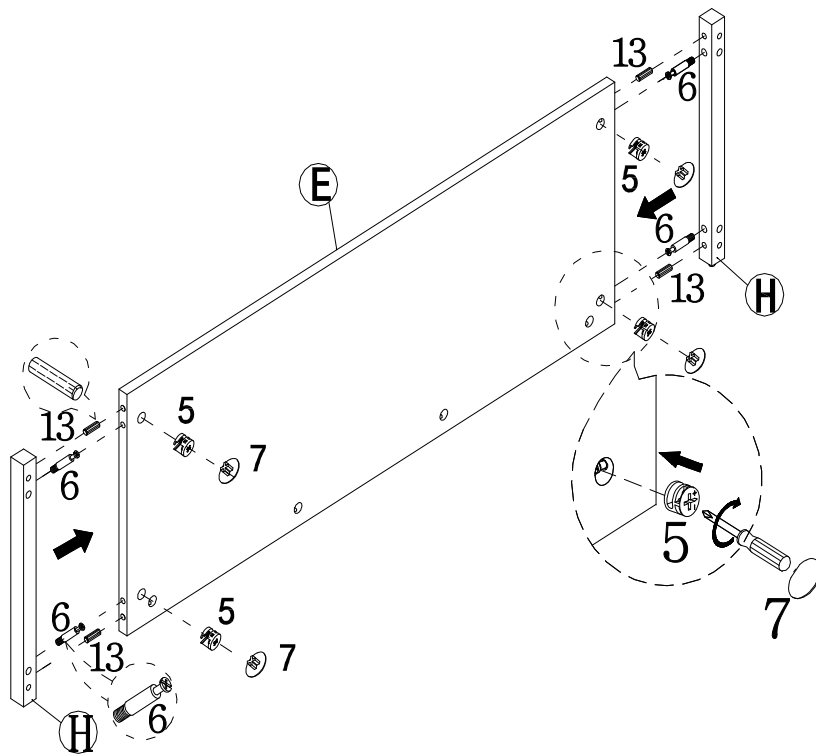

Figure 1

Insert Cam Locks (5) into holes on Back Panel (E).

Screw Cam Bolts (6) into holes on Posts (H).

Attach Posts (H) to Back Panel (E) by inserting Wood Dowels (13) and Cam Bolts (6) into corresponding holes until all panels meet.

Tighten by rotating Cam Locks (5) clockwise with Phillips screwdriver (not included).

Cover all Cam Lock holes with Sticker Covers (7).

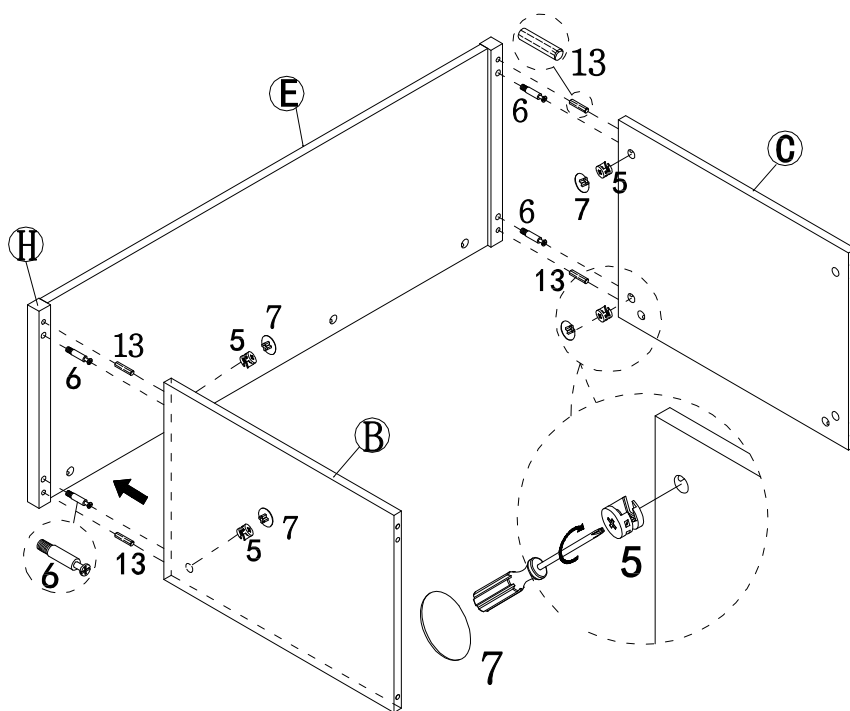

Figure 2

Insert Cam Locks (5) into holes on Left Side Panel (B) and Right Side Panel (C).

Screw Cam Bolts (6) into holes on Posts (H).

Attach Left Side Panel (B) and Right Side Panel (C) to Posts (H) by inserting Wood Dowels (13) and Cam Bolts (6) into corresponding holes until all panels meet.

Tighten by rotating Cam Locks (5) clockwise with Phillips screwdriver (not included).

Cover all Cam Lock holes with Sticker Covers (7).

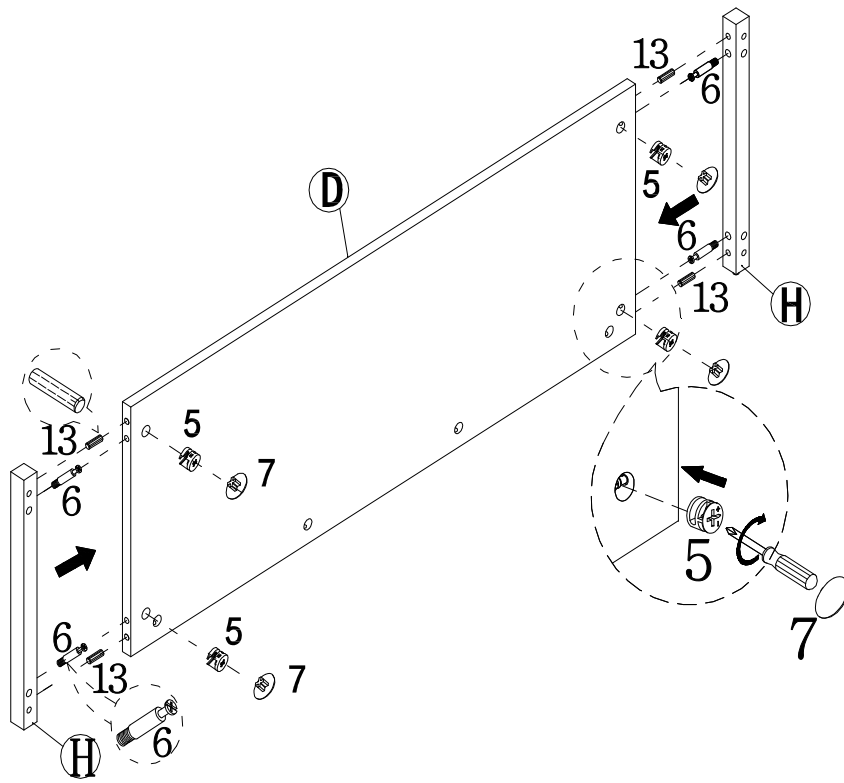

Figure 3

Insert Cam Locks (5) into holes on Front Panel (D).

Screw Cam Bolts (6) into holes on Posts (H).

Attach Posts (H) to Front Panel (D) by inserting Wood Dowels (13) and Cam Bolts (6) into corresponding holes until all panels meet.

Tighten by rotating Cam Locks (5) clockwise with Phillips screwdriver (not included).

Cover all Cam Lock holes with Sticker Covers (7).

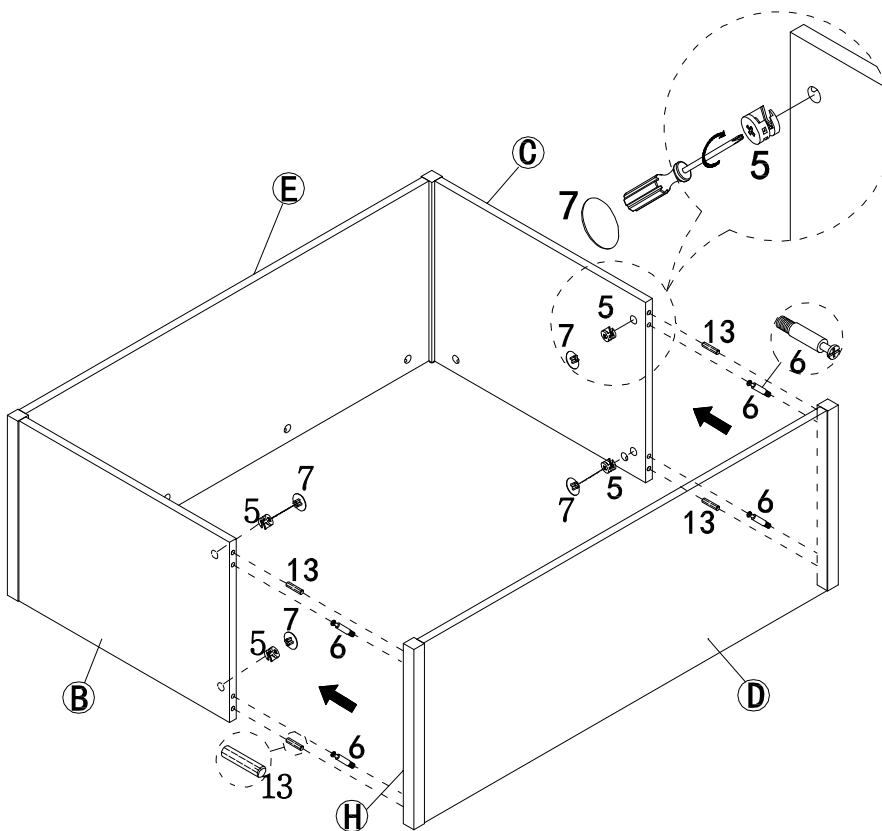

Figure 4

Insert Cam Locks (5) into holes on Left Side Panel (B) and Right Side Panel (C).

Screw Cam Bolts (6) into holes on Posts (H).

Attach Front Panel (D) to Left Side Panel (B) and Right Side Panel (C) by inserting Wood Dowels (13) and Cam Bolts (6) into corresponding holes until all panels meet.

Tighten by rotating Cam Locks (5) clockwise with Phillips screwdriver (not included).

Cover all Cam Lock holes with Sticker Covers (7).

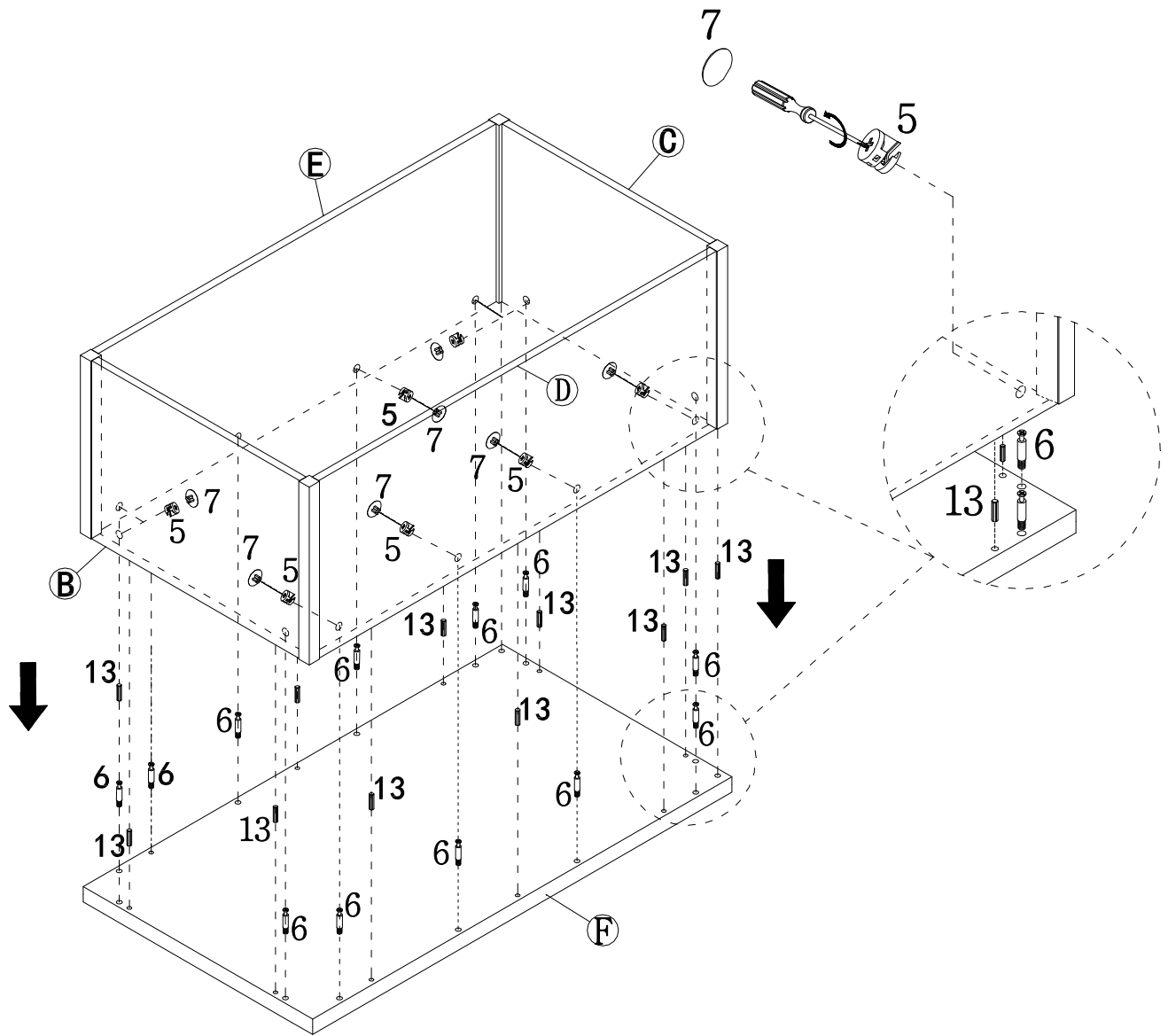

Insert Cam Locks **(5)** into holes on Back Panel **(E)**, Front Panel **(D)**, Left Side Panel **(B)** and Right Side Panel **(C)**.

Screw Cam Bolts **(6)** into holes on Bottom Panel **(F)**.

Attach Bottom Panel **(F)** to assembled unit from Figure 4 by inserting Wood Dowels **(13)** and Cam Bolts **(6)** into corresponding holes until all panels meet.

Tighten by rotating Cam Locks **(5)** clockwise with Phillips screwdriver (not included).

Cover all Cam Lock holes with Sticker Covers **(7)**.

Figure 5

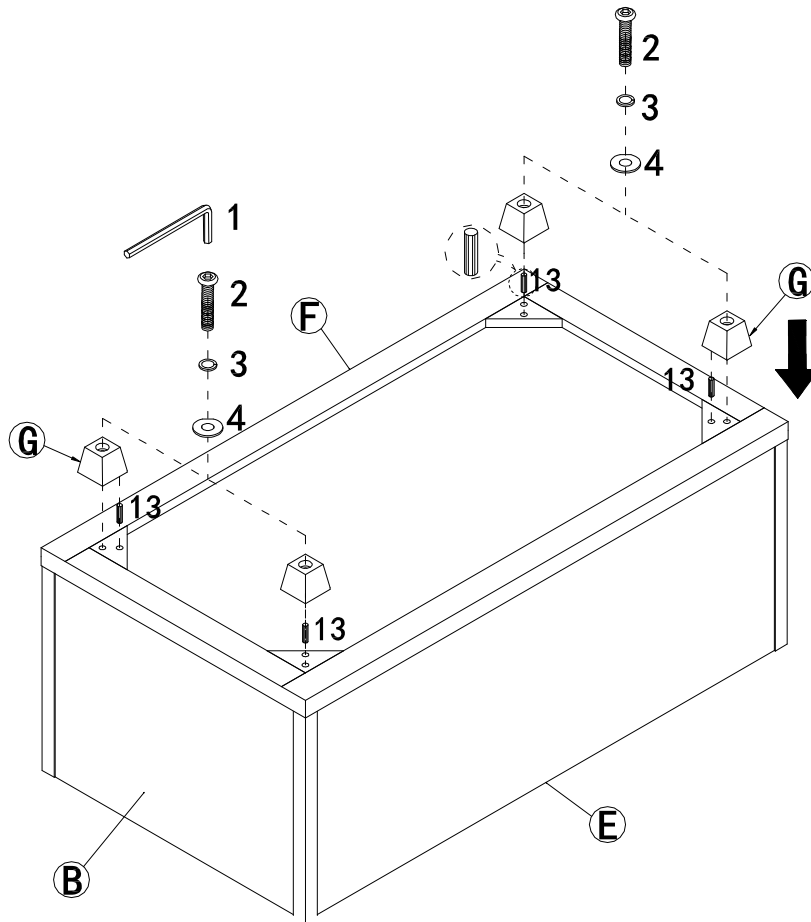

Secure Feet **(G)** to assembled unit from Figure 5 by inserting Wood Dowels **(13)**, Bolts **(2)**, Spring Washers **(3)**, and Flat Washers **(4)**.

Tighten Bolts with Allen Wrench **(1)**.

Figure 6

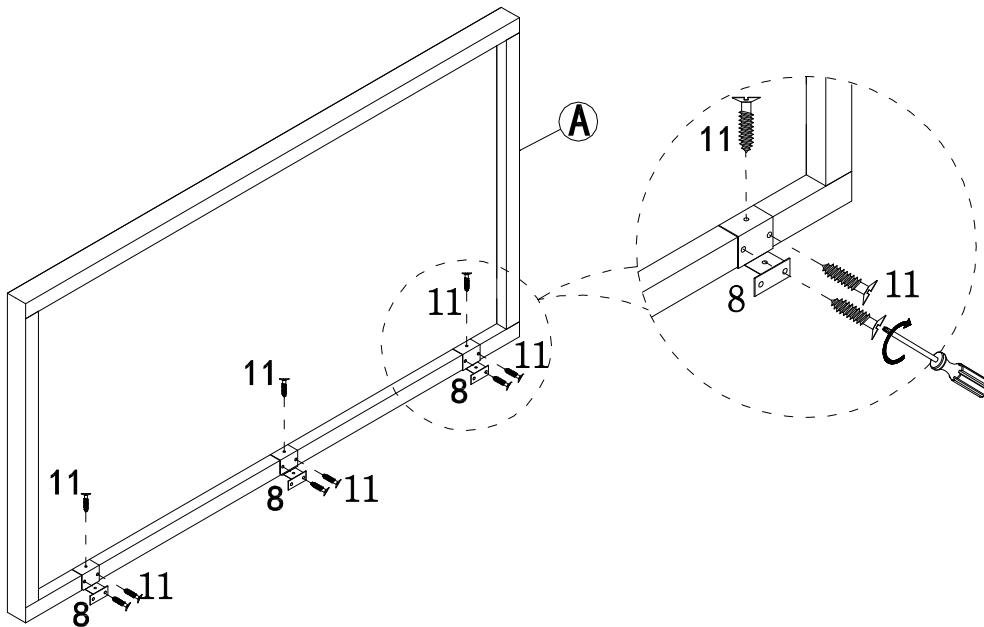

Attach Folded Hinge **(8)** to Top Panel **(A)** using Screws **(11)**.

Tighten Screws **(11)** with Philips Screwdriver (not included).

Figure 7

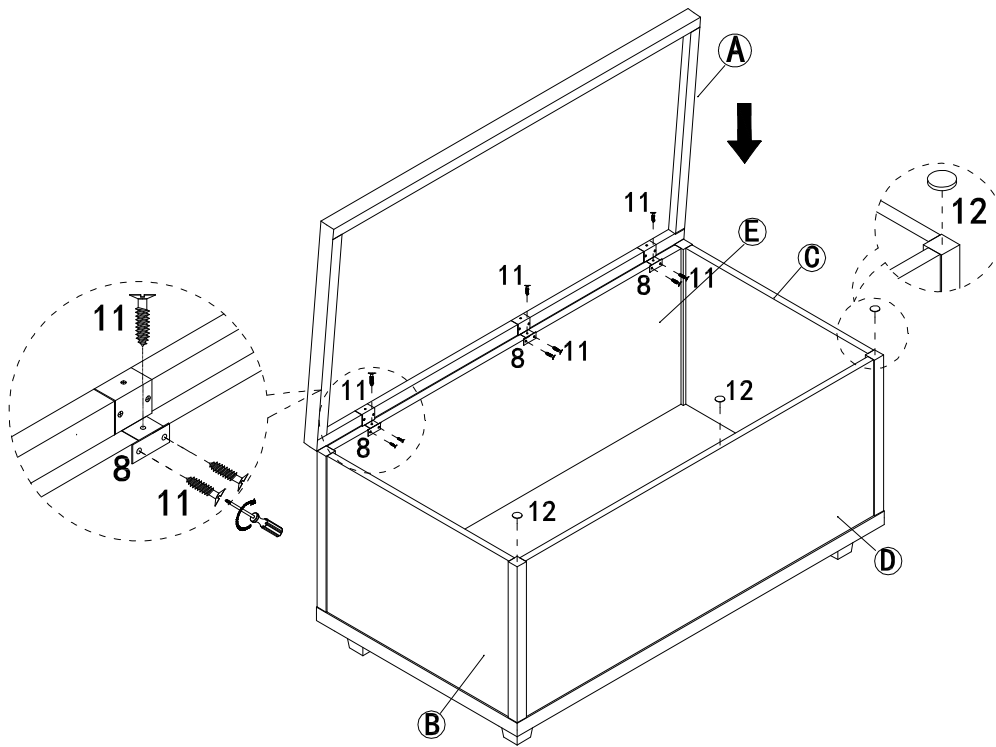

Attach Top Panel (A) to assembled unit from Figure 6 at Folded Hinges (8), using Screws (11).

Tighten Screws (11) with Philips Screwdriver (not included).

Put EVA Pads (12) on front edges of the Trunk.

Figure 8

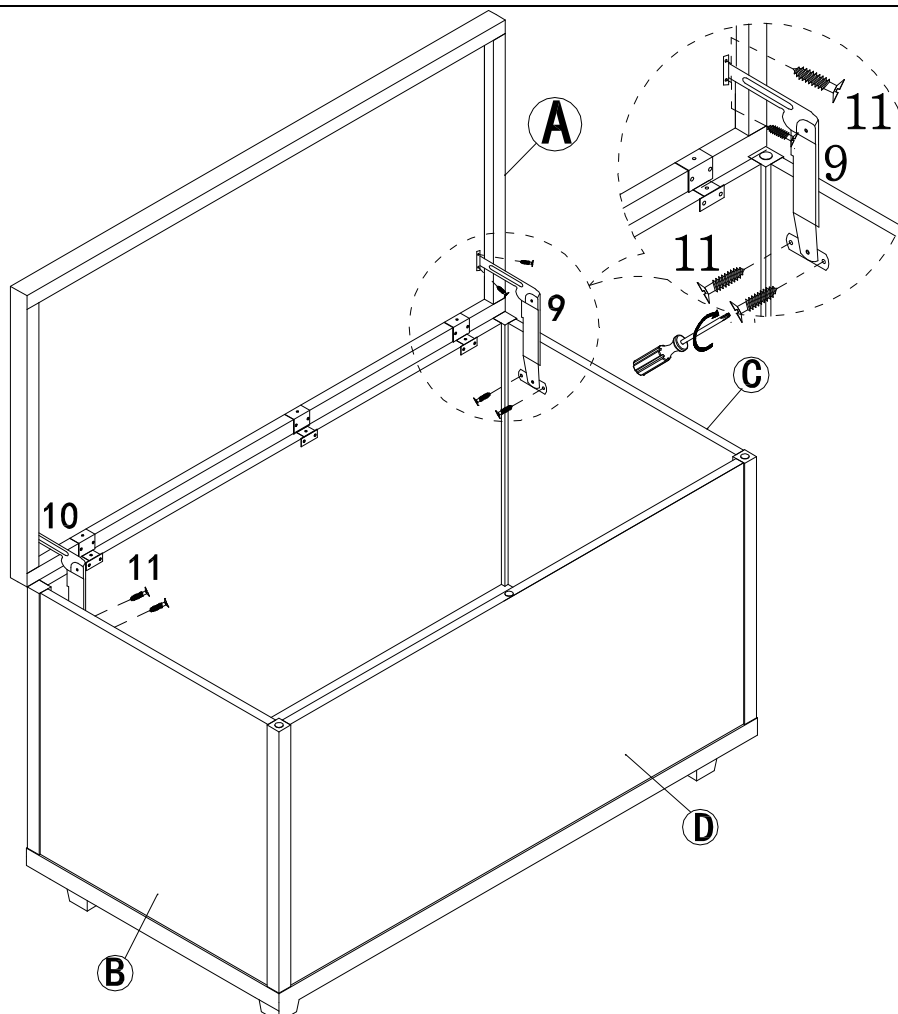

Attach Right Lid Support (9) and Left Lid Support (10) to Top Panel (A), Left Side Panel (B), and Right Side Panel (C) using Screws (11).

Tighten Screws (11) with Philips Screwdriver (not included).

Figure 9

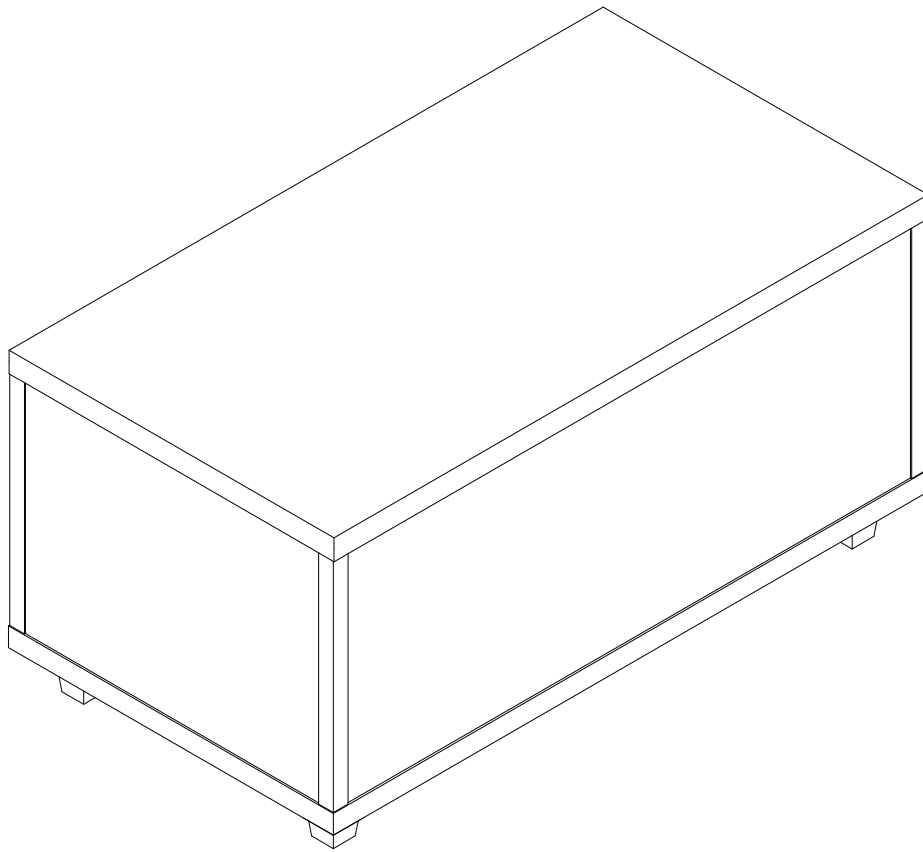

Now your Ryecroft
Cocktail Trunk Table is
ready to use.

Figure 10

Parts Replacement Form

Customer Information

Name _____

Address _____

City/State/Zip Code _____

Phone Number _____

Please indicate where you purchased this item: Store/Website/Catalog

Please indicate color/size/style number:

Style No	Parts Letter	Parts Description	Quantity Needed
_____	_____	_____	_____
_____	_____	_____	_____
_____	_____	_____	_____

Please immediately examine this product carefully. Any request for missing parts or damage replacement must be received within 90 days of your receipt of the product. Replacement, if available, will be honored within this time frame. Parts will not be available for items arriving fully assembled. We do not recommend modifying product(s) and we are not responsible for any damages due to product modification(s). If damages or missing parts are not reported within 90 days of your receipt, we are under no obligation to provide parts or replacement merchandise.

For product issues, please contact Southern Enterprises at 800-633-5096 (toll-free) / 972-869-0111 (Dallas), Mon-Fri 9am – 4pm CST, or email us at service@seidal.com. Please ask for customer service representative for issues involving damages or replacement parts. Please ask for technical assistance representative for any issues with product and assembly/construction.

Please contact the retailer that you purchased from for returns.



Southern
ENTERPRISES

Customer Service: 1-800-633-5096
service@seidal.com

Southern Enterprises, Inc.
600 Freeport Parkway, Suite 200
Coppell, Texas 75019