

HZ031300TX

ALYSSA WINE STORAGE

Assembly Instructions



Southern
ENTERPRISES

For assistance with assembly, contact.
Southern Enterprises Inc.
Customer Service 1-800-633-5096
service@seidal.com
www.seidal.com

PO:13876

Top supports up to 25 lb.

Drawer supports up to 10 lb.

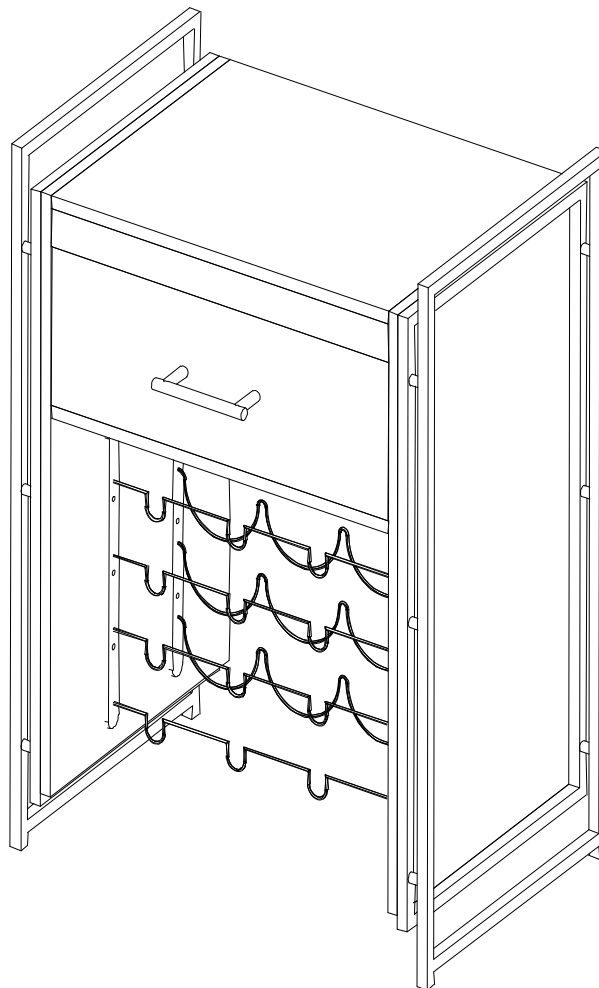

HZ031300TX

ALYSSA WINE STORAGE

Parts List





Please review all parts and hardware before disposing of any packaging.

Call Customer Service if missing hardware.

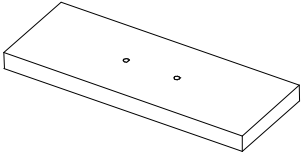
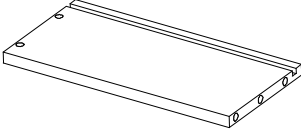
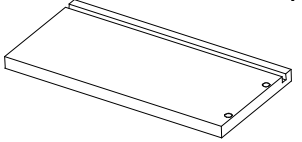
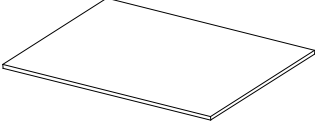
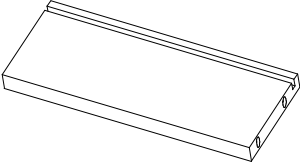
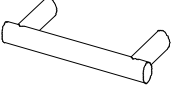
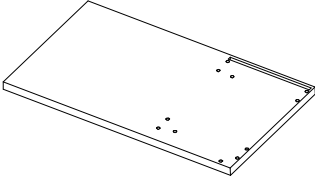
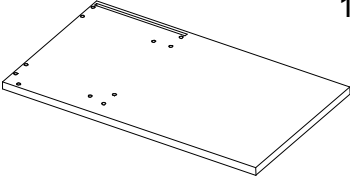
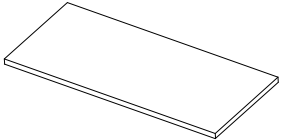
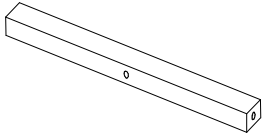
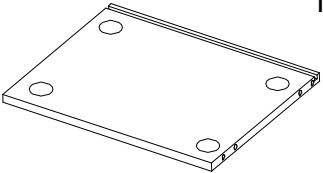
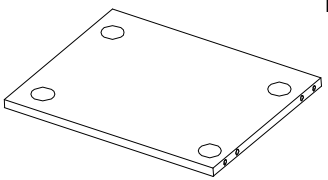
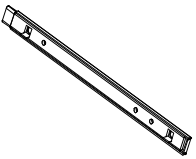
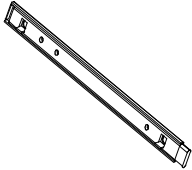
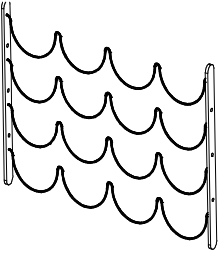
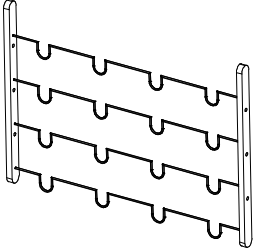
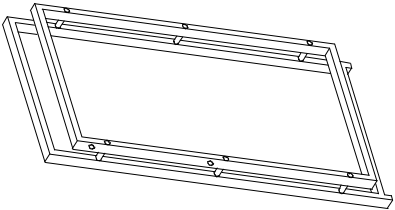
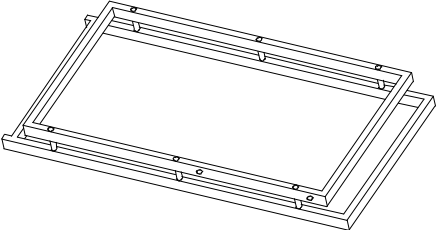
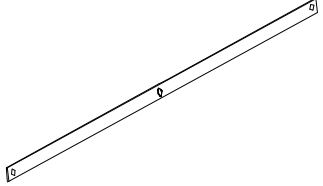
Carefully study the diagrams below.

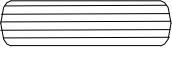
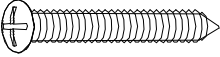
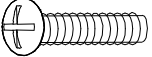
You may receive extra hardware with your unit.

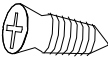
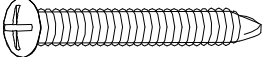
1  Drawer Front	2  Drawer Right Panel	3  Drawer Left Panel
4  Drawer Bottom Panel	5  Drawer Back Panel	6  Handle
7  Right Wood Panel	8  Left Wood Panel	9  Back Panel
10  Stretcher	11  Top Panel	12  Shelf Panel
13 1PC  Left Metal Glide	14 1PC  Right Metal Glide	15  Rear Wine Bottle Panel
		16  Front Wine Bottle Panel
17  Right Metal Panel	18  Left Metal Panel	19  Metal Stretchers

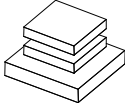
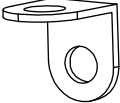
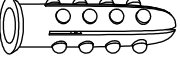
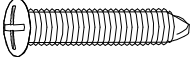
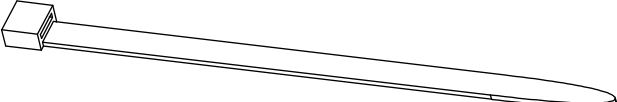
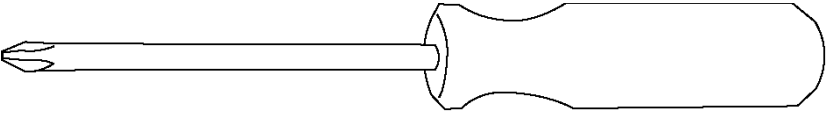
<p>A 12PCS</p>  <p>Screws 4x12mm</p>	<p>B 14PCS</p>  <p>Wood Dowel 8x30mm</p>	<p>C 4PCS</p>  <p>Screws 4x32mm</p>	<p>D 10PCS</p>  <p>Bolts 4x25mm</p>
<p>E 10PCS</p>  <p>Cam Locks</p>	<p>F 10PCS</p>  <p>Cam Bolts</p>	<p>G 8PCS</p>  <p>Screws 4x12mm</p>	<p>H 1PC</p>  <p>Screws 4x38mm</p>
<p>I 5PCS</p>  <p>Bolts 4x9mm</p>	<p>J 1PC</p>  <p>Nut</p>	<p>K 4PCS</p>  <p>End Caps</p>	<p>L 4PCS</p>  <p>L Metal Chip</p>
<p>M 2PCS</p>  <p>Plastic Wall Anchor</p>	<p>N 2PCS</p>  <p>Screws 4x25mm</p>	<p>O 2PCS</p>  <p>Plastic Straps</p>	
<p>Care and Cleaning Instructions: Before using, wipe with a clean, dry cloth. Avoid rubbing or scratching the surface with rough or abrasive objects.</p>		<p>For replacement parts or questions, please call customer service at 1-800-633-5096.</p>	
<p>Assembly Tool Required No.2 Phillips Screwdriver</p>			

HZ031300TX

ALYSSA WINE STORAGE

Assembly Instructions

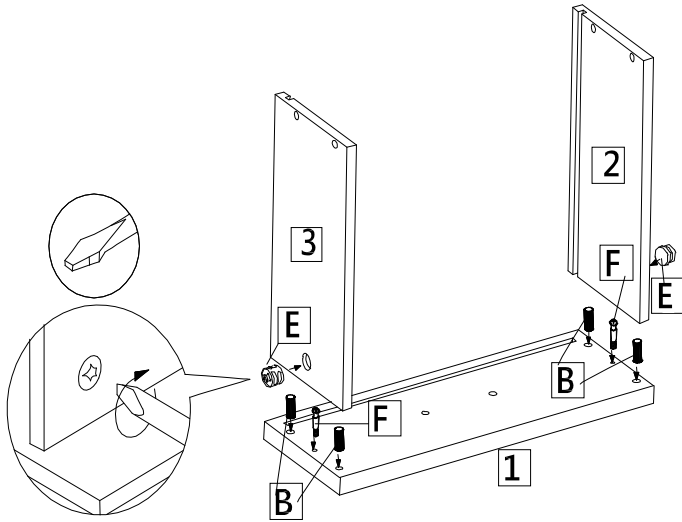

Step 1:

Attach Drawer Right Panel (2) and Drawer Left Panel (3) to Drawer Front (1) using Wood Dowels (B) and Cam Bolts (F) as shown.

Fix Drawer Right Panel (2) and Drawer Left Panel (3) to Drawer Front (1) with Cam Locks (E) as shown.

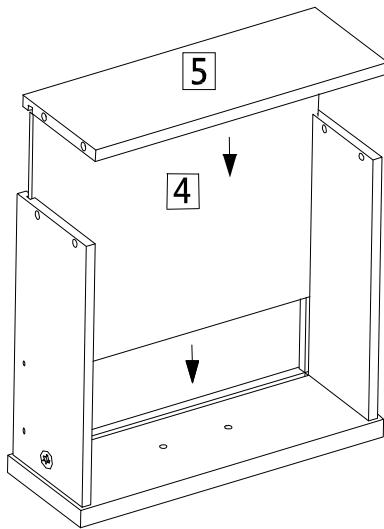

Step 2:

Slide Drawer Bottom Panel (4) along the grooves of Drawer Right Panel (2) and Drawer Left Panel (3).

Then, attach Drawer Back Panel (5) to Drawer Right Panel (2) and Drawer Left Panel (3) as shown.

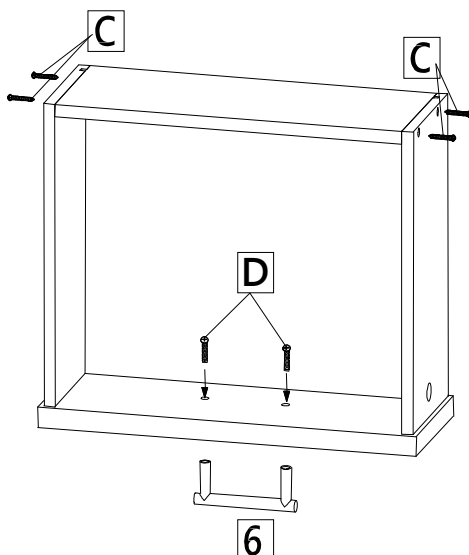

Step 3:

Fix Drawer Back Panel (5) to Drawer Right Panel (2) and Drawer Left Panel (3) using Screws (C).

Attach Handle (6) to Drawer Front (1) using Bolts (D) as shown.

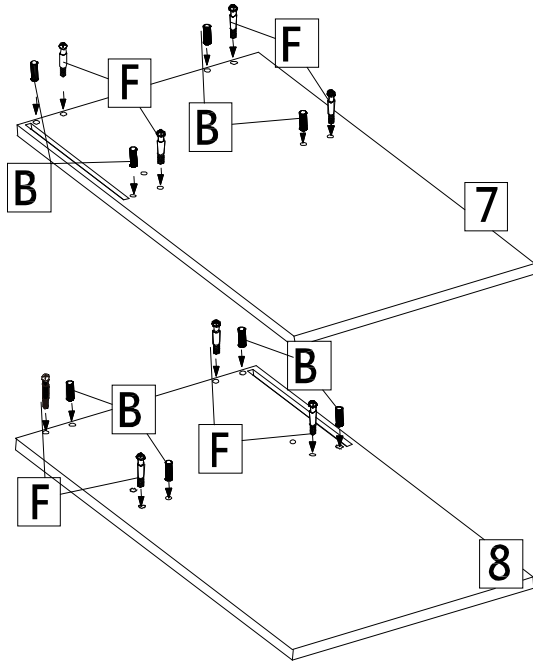

Step 4:

Attach Wood Dowels (**B**) and Cam Bolts (**F**) to Right Wood Panel (**7**) and Left Wood Panel (**8**) as shown.

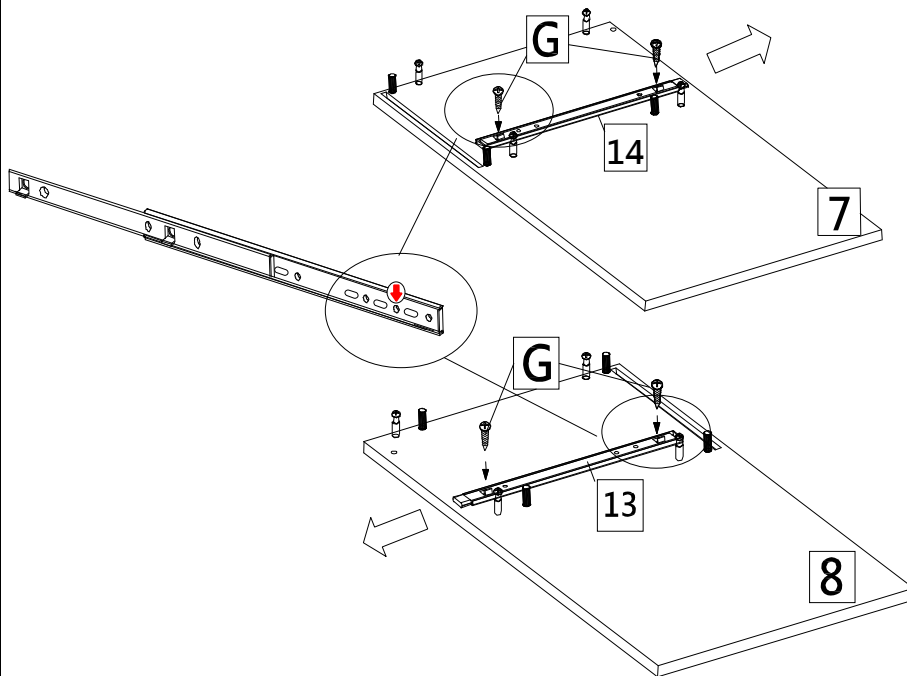

Step 5:

Please pull out Left Metal Glide (**13**) and Right Metal Glide (**14**). Aim at the hole with arrow tip label on Metal Glides (**13**), (**14**) and the pre-drilled holes on Right Wood Panel (**7**) and Left Wood Panel (**8**) to attach Left Metal Glide (**13**) and Right Metal Glide (**14**) using Screws (**G**) as shown.

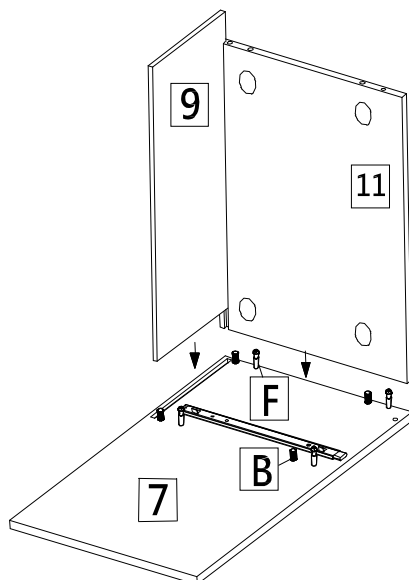

Step 6:

Attach Top Panel (**11**) to Right Wood Panel (**7**) and slide Back Panel (**9**) along the groove of Top Panel (**11**) as shown. .

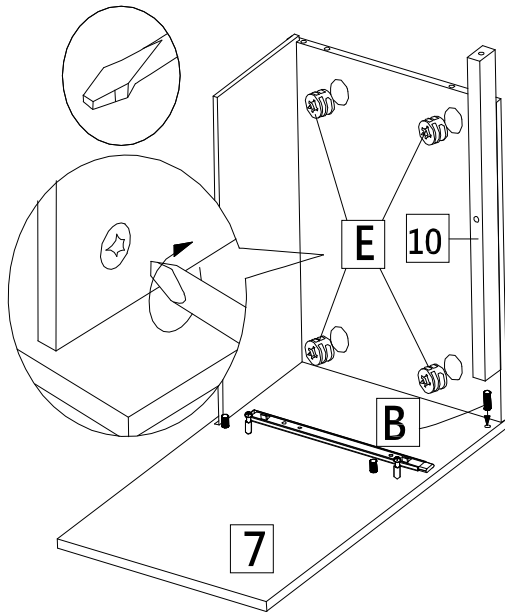

Step 7:

Fix Top Panel (11) to Right Wood Panel (7) using Cam Locks (E).

Using Wood Dowels (B), attach Stretcher (10) to Right Wood Panel (7) as shown.

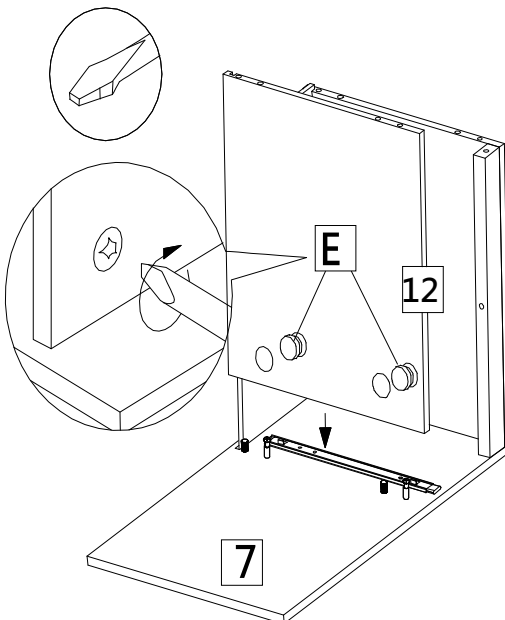

Step 8:

Attach Shelf Panel (12) to Right Wood Panel (7). The groove of Shelf Panel (12) is facing along Back Panel (9) as shown.

Fix Shelf Panel (12) to Left Wood Panel (8) using Cam Locks (E).

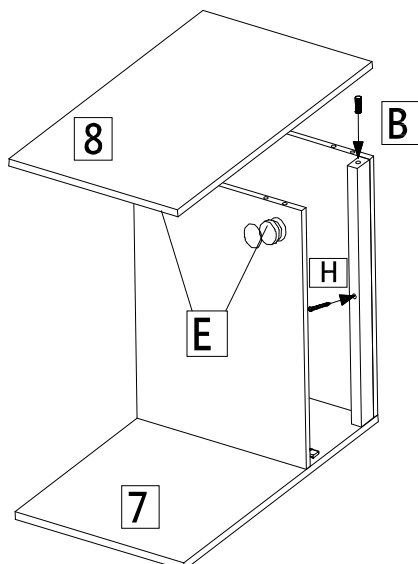

Step 9:

Attach Wood Dowel (B) to Stretcher (10). Then, attach Left Wood Panel (8) to Top Panel (11) and Shelf Panel (12) as shown.

Fix Stretcher (10) to Top Panel (11) using Screw (H) and fix Shelf Panel (12) to Right Wood Panel (7) using Cam Locks (E) again.

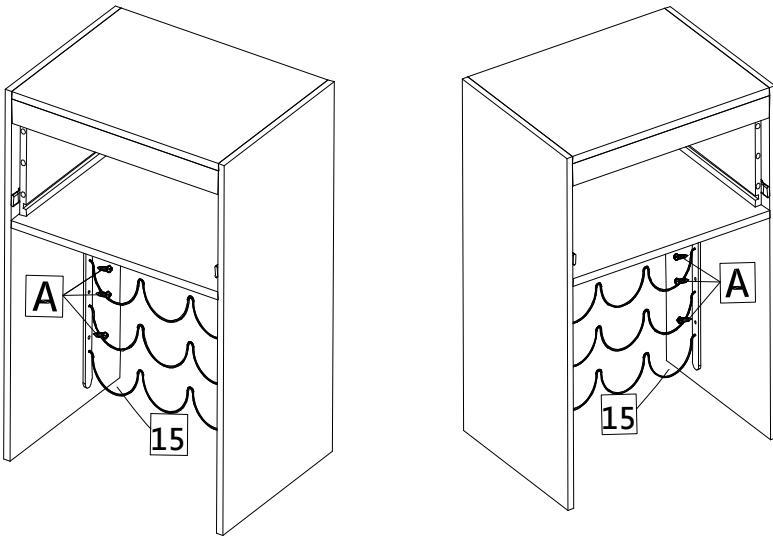

Step 10:

Aim at the pre-drilled holes on Right Wood Panel (7) and Left Wood Panel (8) to attach Rear Wine Bottle Panel (15) using Screws (A) as shown.

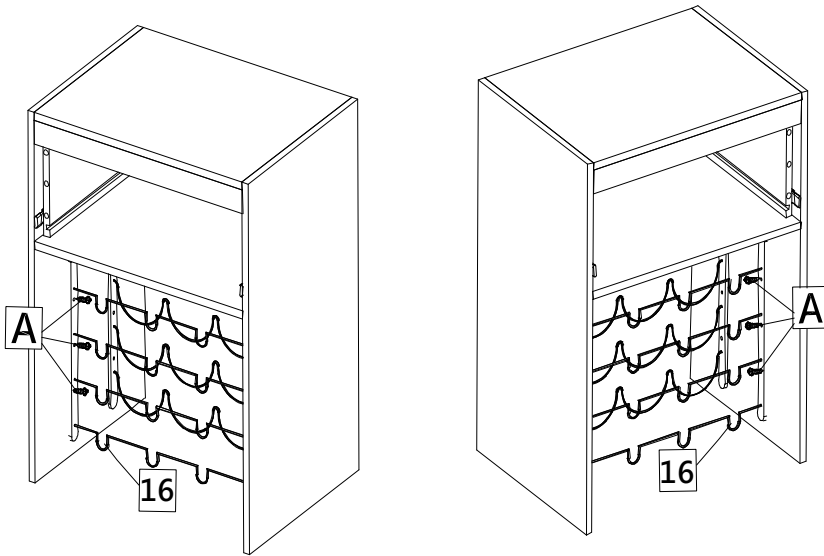

Step 11:

Then, using Screws (A) again, aim at the pre-drilled holes on Right Wood Panel (7) and Left Wood Panel (8) to attach Front Wine Bottle Panel (16) as shown.

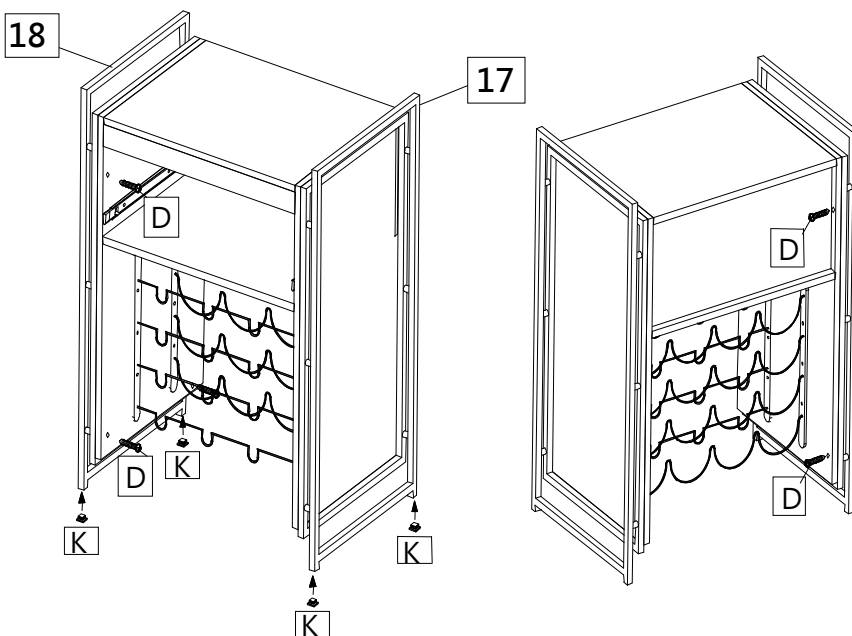

Step 12:

Attach End Caps (K) to Right Metal Panel (17) and Left Metal Panel (18).

Then, attach Right Metal Panel (17) and Left Metal Panel (18) using Bolts (D) as shown.

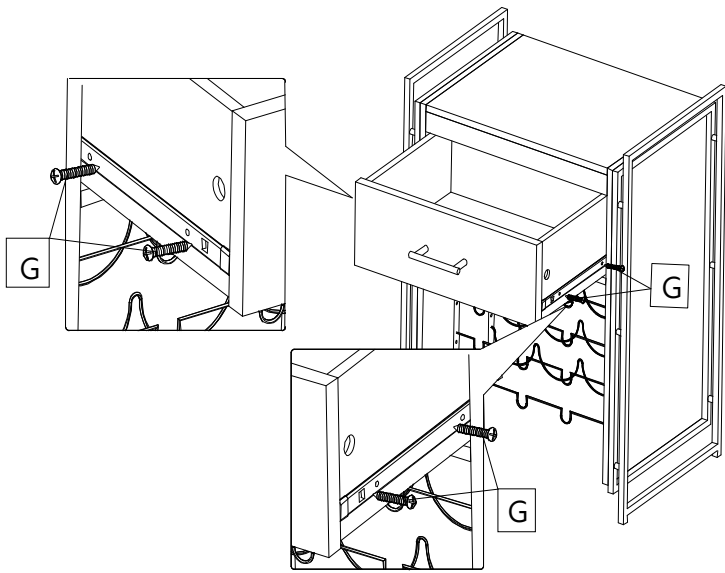

Step 13:

Pull out Left Metal Glide (13) and Right Metal Glide (14) first.

Then, put the assembled drawer to the frame of drawer and aim at the pre-drilled holes on Drawer Right Panel (2) and Drawer Left Panel (3) to attach Left Metal Glide (13) and Right Metal Glide (14) to assembled drawer using Screws (G) as shown.

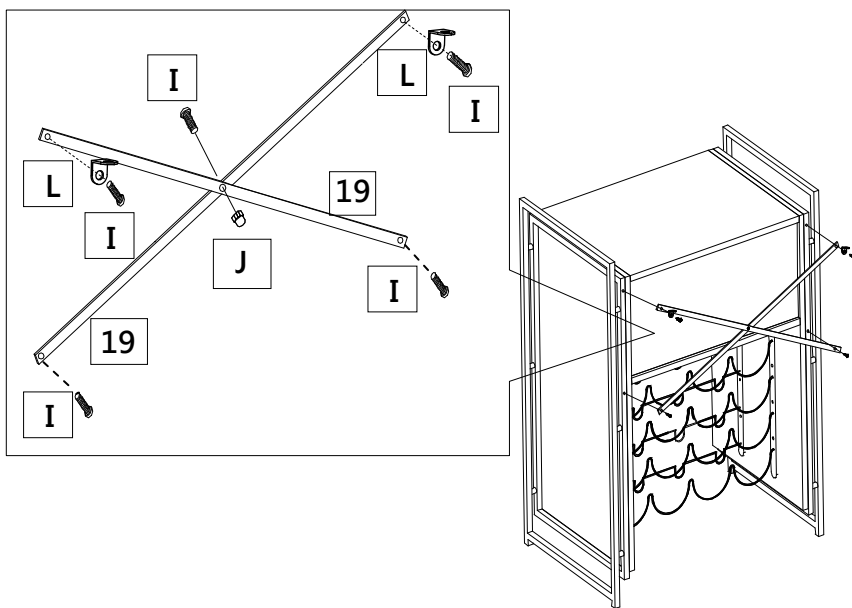

Step 14:

Connecting Metal Stretchers together using Bolts (I) and Nut (J).

Then, Attach Metal Stretchers (19) and L Metal Chips (L) (Anti-tipping Hardware) to Right Metal Panel (17) and Left Metal Panel (18) using Bolts (I) as shown.

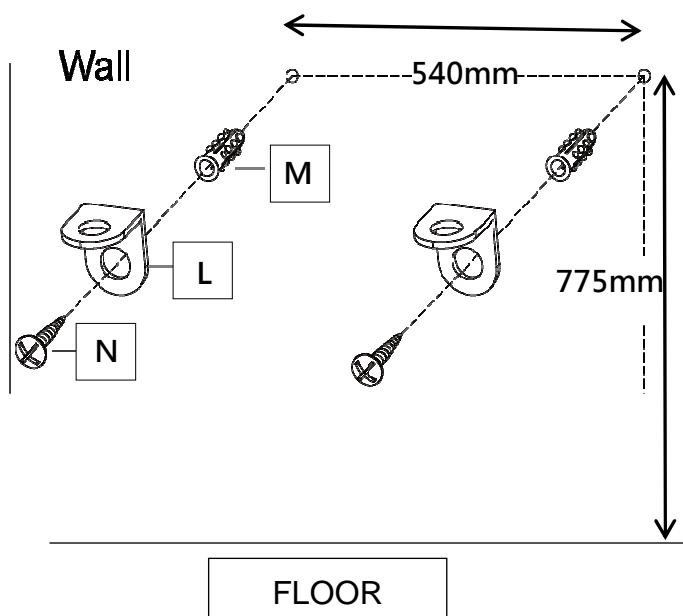

Anti-tipping Hardware Must be Used for this product to avoid tipping and injury

Tip: Screw must be directly mounted into a wall stud. Wall anchor is not needed when mounting into a wall stud.

Find an ideal location on the wall and mark the location of the center of each mounting hole.

Using a power drill and a 3/16" drill bit, drill two 3/16" holes on the wall.

Note: Make sure not to drill into electrical wiring or plumbing pipes.

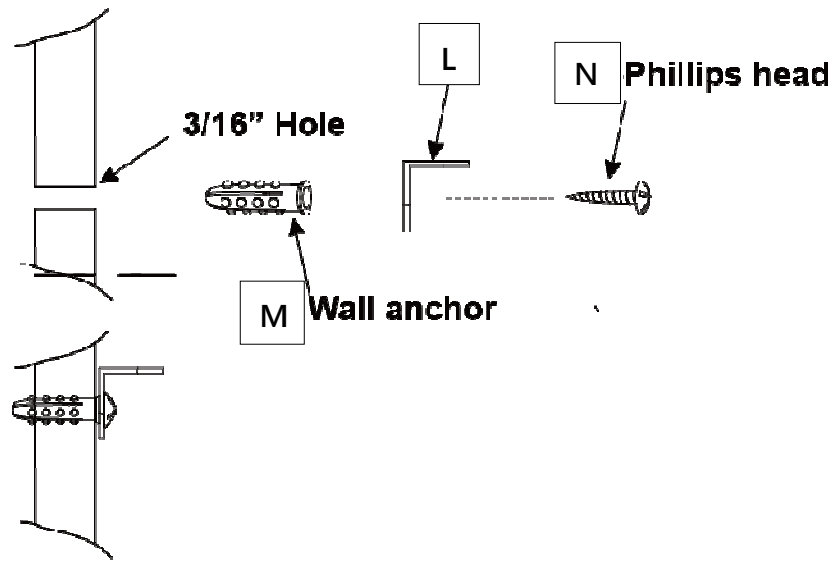

Insert Wall Anchors (**M**) into the two 3/16" holes. Make sure that the wall anchors are flush with the wall.

Tip: It may be necessary to use a hammer to gently tap the anchors into place.

Attach L Metal Chips (**L**) to Wall Anchors (**M**) using Phillips Head Screws (**N**) and the Phillips Screwdriver as shown.

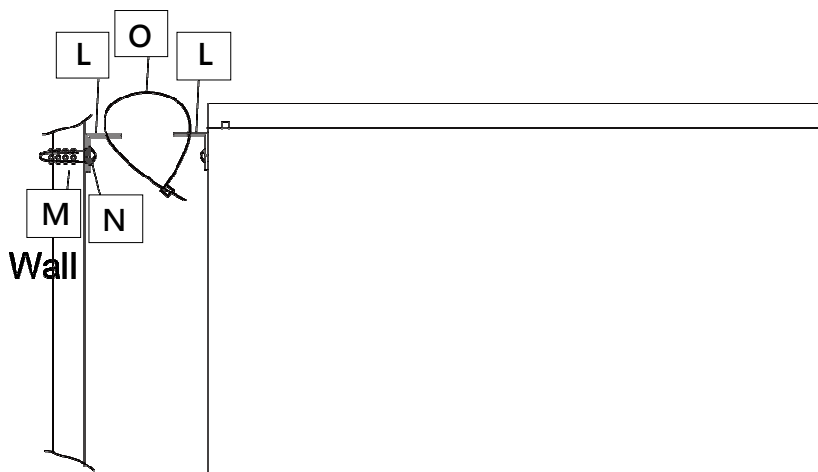

Attach Plastic Straps (**O**) to L Metal Chips (**L**) on the wall and wine storage as shown.

Your Alyssa Wine Storage assembly is now complete.

Parts Replacement Form

Customer Information

Name _____

Address _____

City/State/Zip Code _____

Phone Number _____

Please indicate where you purchased this item: Store/Website/Catalog

Please indicate color/size/style number:

Style No	Parts Letter	Parts Description	Quantity Needed
_____	_____	_____	_____
_____	_____	_____	_____
_____	_____	_____	_____

Please immediately examine this product carefully. Any request for missing parts or damage replacement must be received within 90 days of your receipt of the product. Replacement, if available, will be honored within this time frame. Parts will not be available for items arriving fully assembled. We do not recommend modifying product(s) and we are not responsible for any damages due to product modification(s). If damages or missing parts are not reported within 90 days of your receipt, we are under no obligation to provide parts or replacement merchandise.

Please contact Southern Enterprises at 800-633-5096 or in Dallas 972-869-0111/ 9am – 4pm Mon-Fri Central time if you have product issues or email us at service@seidal.com. Please ask for customer service representative for issues involving damages or replacement parts. Please ask for technical assistance representative for any issues with product and assembly/construction.

Please contact the retailer that you purchased from for returns.



Southern
ENTERPRISES

Customer Service 1-800-633-5096
service@seidal.com
Southern Enterprises, Inc.
600 Freeport Parkway, Suite 200
Coppell, Texas 75019