

88 9001 007C Cuisine Cart

IMPORTANT NOTE

Carefully remove all the parts from the carton and put them individually on a soft cloth to prevent scratches or other damages occurring to the parts.

We have taken great care in the design of this product and request that you carefully and strictly follow our assembly instructions to ensure a completed product as it was designed.

Home Styles

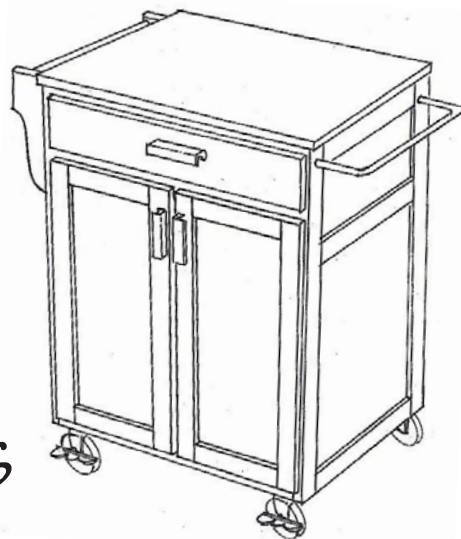

PART LIST

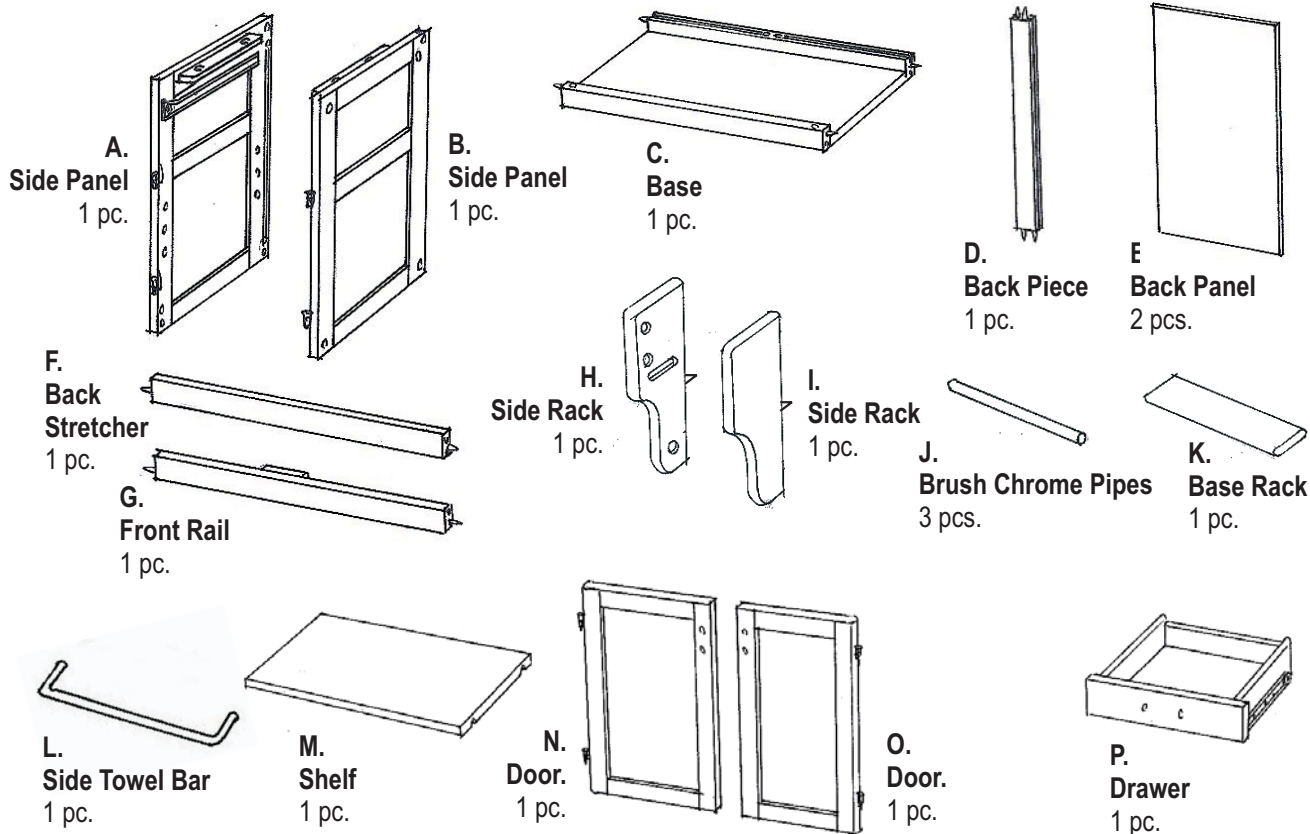

HARDWARE LIST

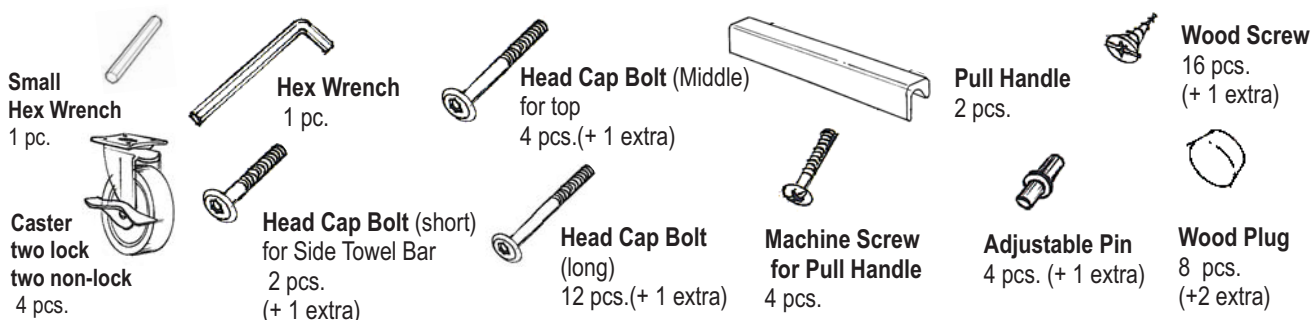

Tools Required For Assembly : Phillips screwdriver

Home Styles Consumer Assistance Line 888-680-7460 and 877-831-0319

servicedesk@homestyles-furniture.com

Revised date : 24Mar2011

Assembly Instructions 2/4

IMPORTANT

Do not tighten up all the screws until each part is properly assembled.
You should keep Hex Wrench in the safe place as you may need to tighten up the Head Cap Bolts in the future.

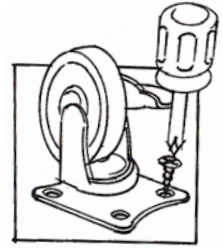

STEP 1

Attach four Casters to the underneath of the Base (C).

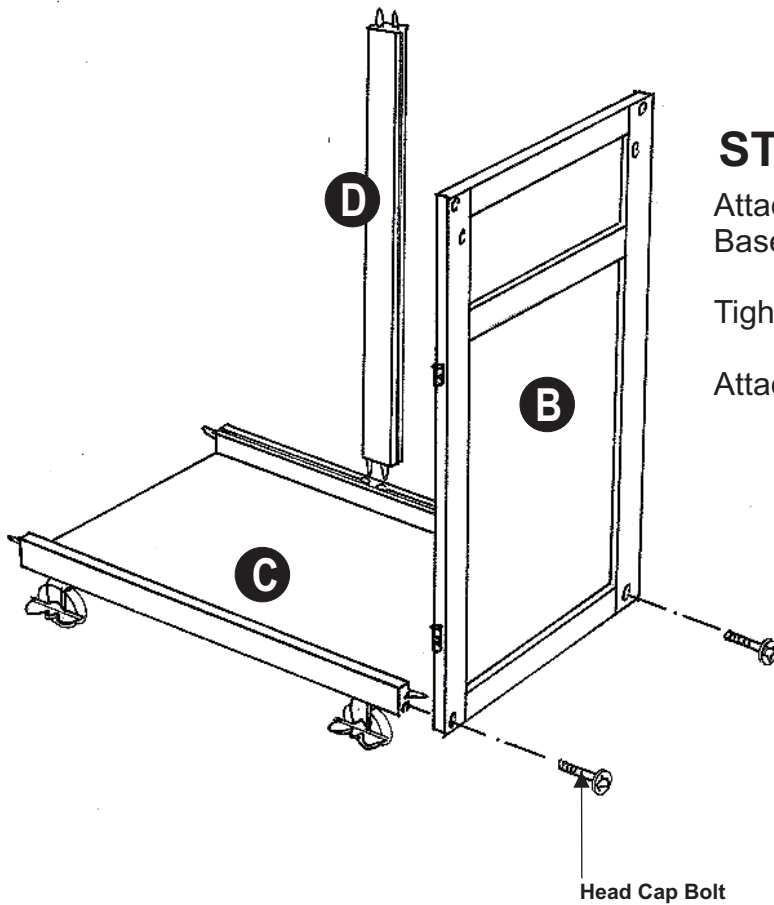
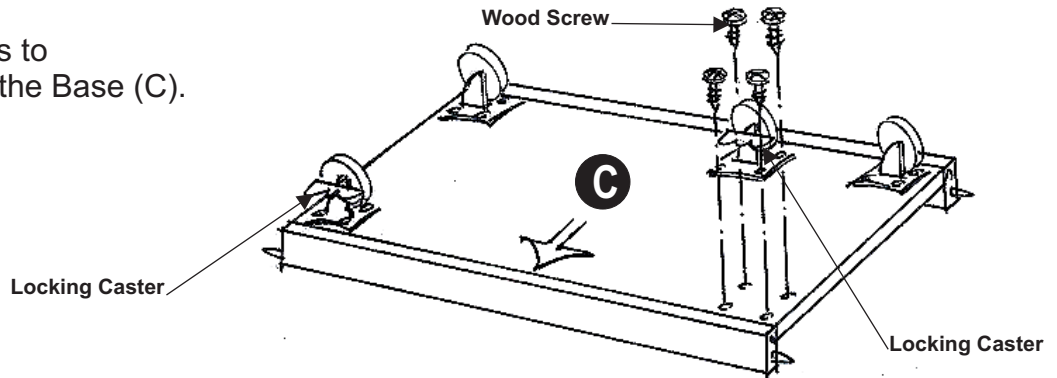

STEP 2

Attach the Side Panel (B) to the Base (C).

Tighten up the Head Cap Bolts.

Attach the Back Piece (D) on the Base rear.

Tighten Head Cap Bolt by Hex Wrench.

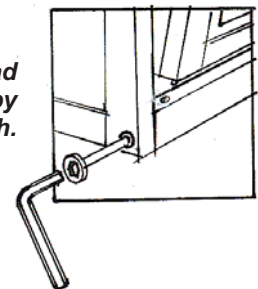

Assembly Instructions 3/4

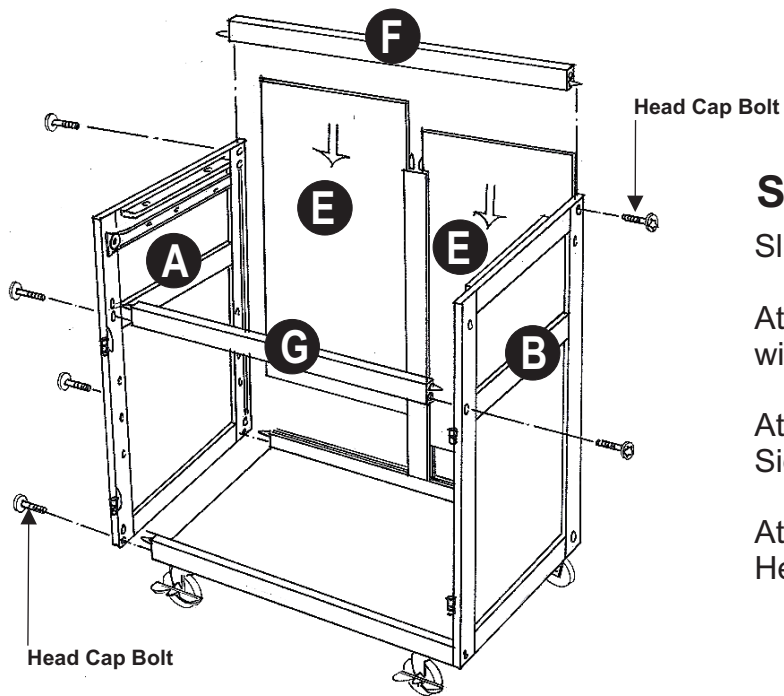

STEP 3

Slide the Back Panel (E) in place.

Attach the Back Stretcher (F) on the unit with the Head Cap Bolt.

Attach the Front Rail (G) to the Side Panel (B) with Head Cap Bolt.

Attach the Side Panel (A) to the unit with Head Cap Bolts.

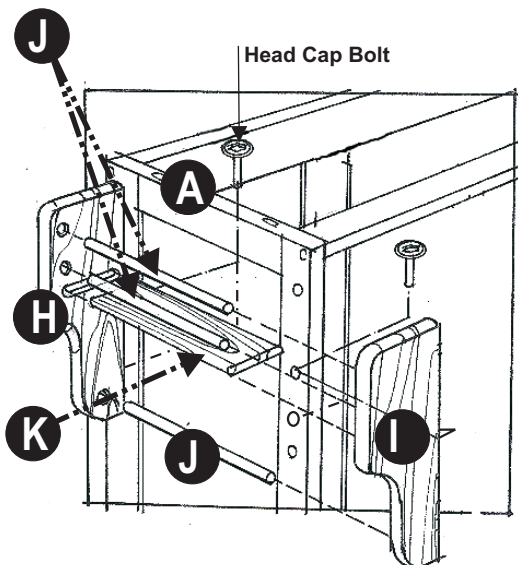

STEP 4

Attach the Side Rack (H) to the Side Panel (A) with the Head Cap Bolts.

Attach the Brush Chrome Pipes (J) to the pre-drilled holes of Side Rack (H).

Attach the Base Rack (K) to the Side Rack (H).

Attach the Side Rack (I) to the Side Panel (A), using Head Cap Bolts.

STEP 5

Attach the Side Towel Bar (L) to the Side Panel (B) with Head Cap Bolts.

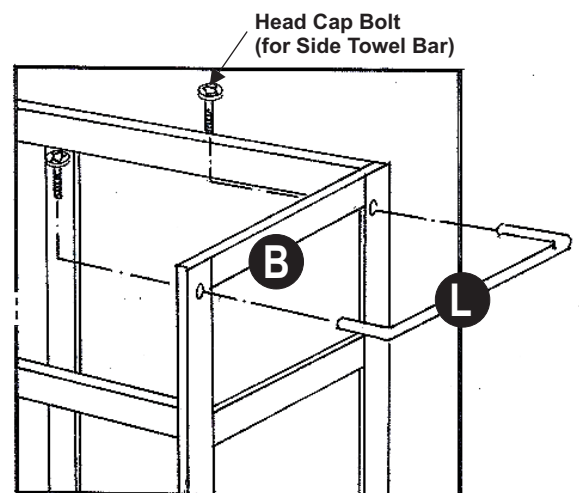

STEP 6

Now, you'll be able to create your own kitchen cart. Make your own choice of the 'Top', wood or stainless steel or granite.

Place the Top on the unit, then tighten the Head Cap Bolts.

Insert the Adjustable Pins into both side panels at the desired level.

Place Shelf (M) into place.

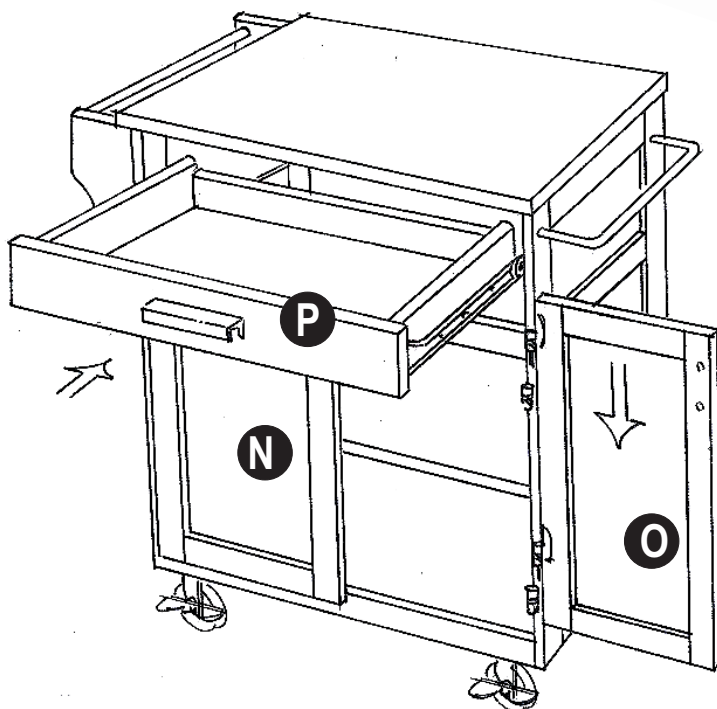
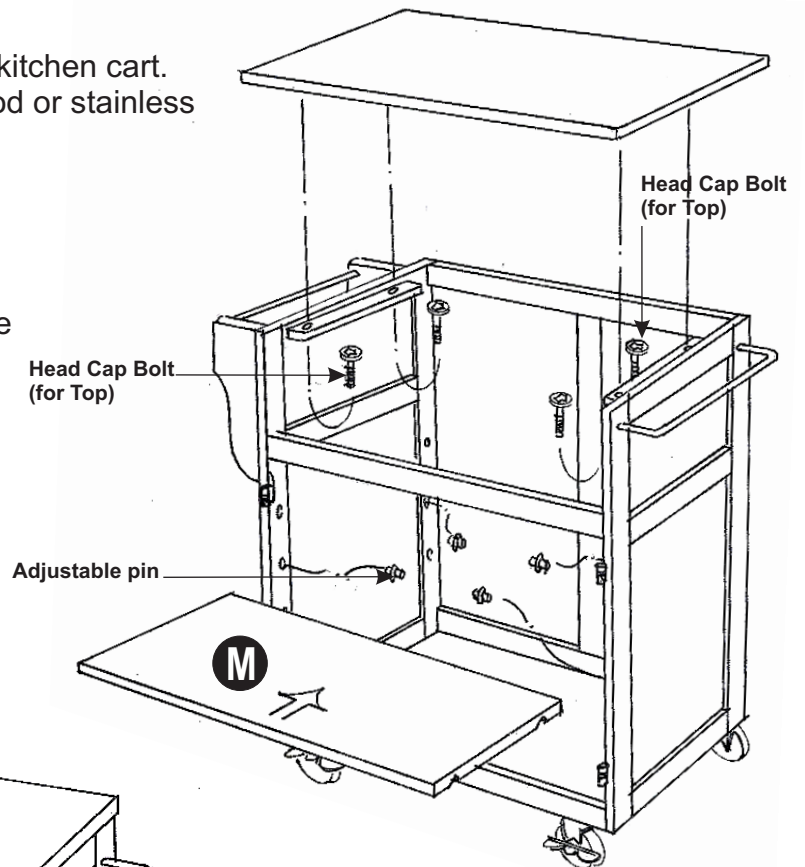

STEP 7

Attach the Pull Handles to the Door (N) and (O) using the Machine Screws. (See figure 1)

Attach the Door (N) and (O) to both side panels, slide the door lift hinges into the side frame lift hinges. (See figure 2)

Slide the Drawer (P) into place. (Drawer is packed in separated carton).

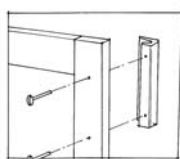

Figure 1

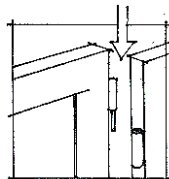
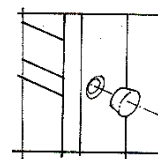

Figure 2







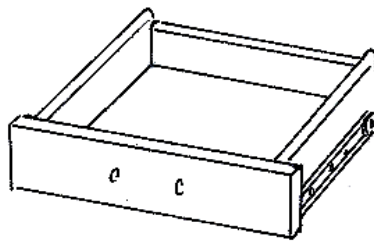

STEP 8

Cover up all holes with Wood Plugs

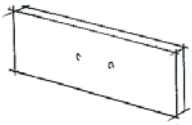
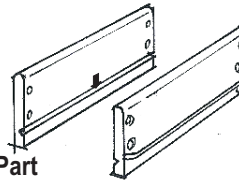
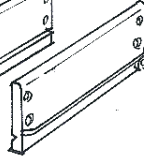
88 9001 007C Drawer (P)

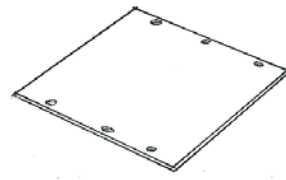

* If you are missing any of these parts, please contact our DMI Customer Service Department at 1-877-831-0319 or fax us at 1-800-755-2878.

Unit Part List		HARDWARE LIST	
 P1. Front Part 1 pc.	 P3. Side Part 1 pc.	 P4. Side Part 1 pc.	 Pull Handle 1 pc.
 P2. Back Part 1 pc.	 P5. Base 1 pc.	 Machine Screw for Pull Handle 2 pc.	 Wood Screw (for Base) 6 pcs.(+1 extra)
			 Wood Screw (for Side Part) 8 pcs.(+1 extra)

Assembly Instructions

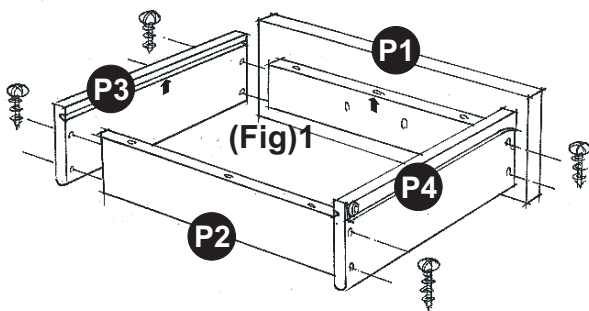

(Fig) 1

Assemble the Front Part (P1), Back Part (P2) and Side Part (P3) and (P4). Using a Phillips screw driver, insert 1" screw into the pre-drilled holes at the side parts, tighten half way.

(Fig) 2

Slide the Plywood Base (P5) into the grooves on side parts. Be sure to push the Base all the way forward so it meets the Front Part.

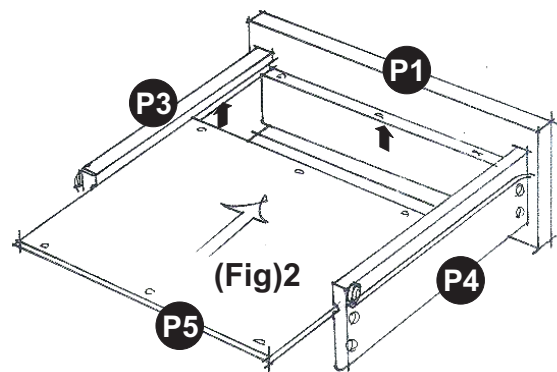

(Fig) 3

Insert the remaining 1/2" screws (6 pcs.) into the pre-drilled holes at the Base, then tighten up all screws.

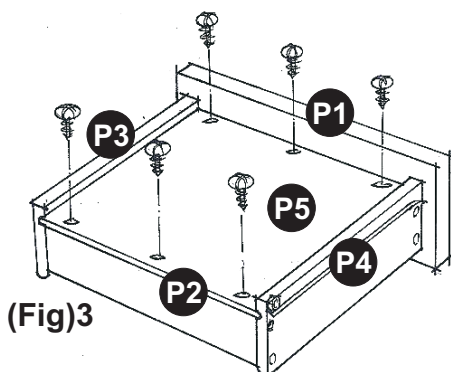

(Fig)3

(Fig) 4

Assemble the Pull Handle to the Front Part with Machine Screw.

