

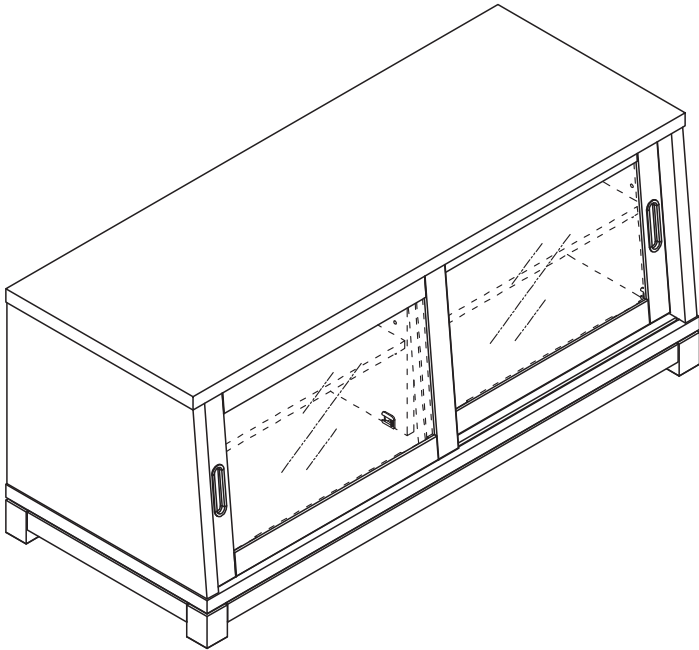

TV3347NCR TV STAND ASSEMBLY INSTRUCTIONS



WARNING

1. Do not use this product unless all screws and bolts are securely tightened.
2. Check that all screws and bolts are tight every three months or as needed.
3. Dispose of packing material properly. Do not use plastic cover as head covering. It may cause suffocation.
4. Do not use this product as a stepladder.
5. Use this product for its intended purpose only.
6. **Intended for residential use only.**

LIMITED WARRANTY

OSP Designs Warrants, to the original purchaser its products to be free from defects in material and workmanship for a period of 90 days. Defects and damage from misuse, abuse, negligence, alteration, accident, vandalism, rusting, acts of nature or any other event beyond the control of OSP Designs is not covered. The warranty does not cover cosmetic damage that may result from normal use. Liability for incidental or consequential damages is excluded. The user assumes all risk of injury resulting from use of this product. This warranty gives you specific legal rights, and you may also have other rights which vary from state to state.

To make a warranty claim, contact Customer Service, provide model number, sales receipt and description of the problem. It is the customer's responsibility to prepay freight on any components returned to the factory. OSP Designs will pay return freight on components covered under terms of warranty.

Our quality standards are among the highest in the industry. Sometimes, no matter how hard we try, there are times when hardware is missing. Our Parts Department will do everything possible to promptly remedy the problem. Contact us via email parts@officestar.net, by Fax 1-909-930-5629, or toll free parts number 1-800-950-7262, Monday through Friday 8:00 a.m. - 5:00 p.m. Pacific Time. OSP Designs P.O. Box 3520 Ontario, California 91761 USA

PARTS LIST

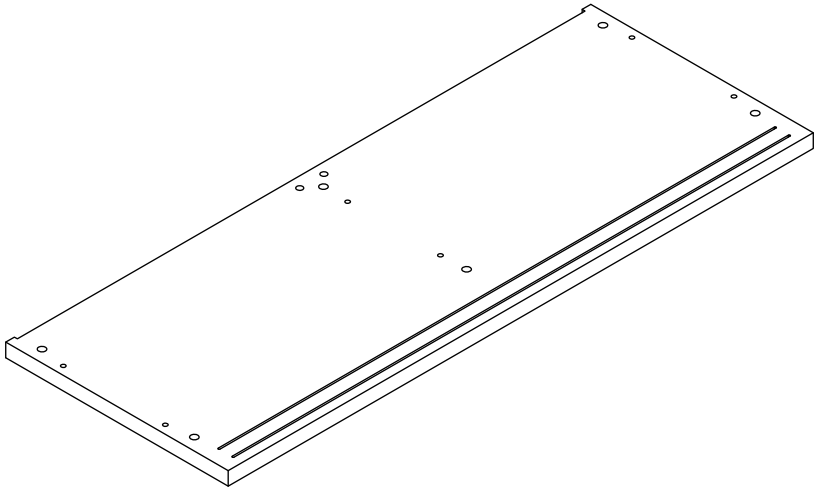

(1) TOP PANEL (1 PC)



(2) FOOT (4 PCS)

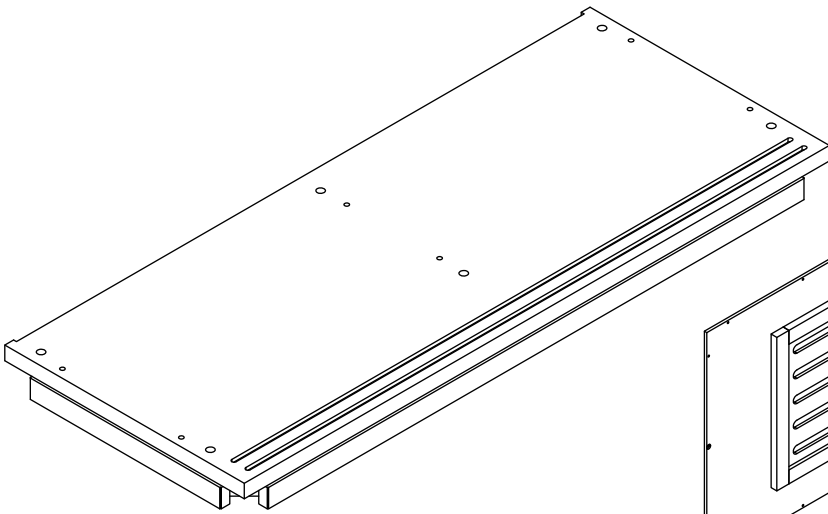

(3) BOTTOM PANEL (1 PC)

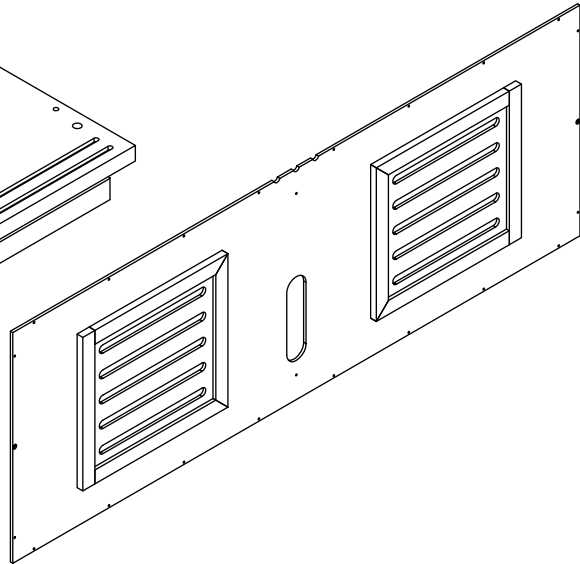

(4) BACK PANEL (1 PC)

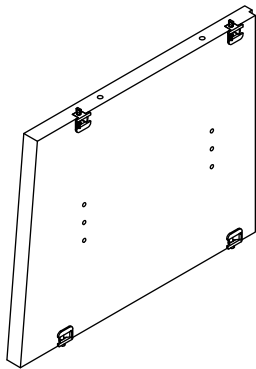

(5) LEFT SIDE PANEL (1 PC)

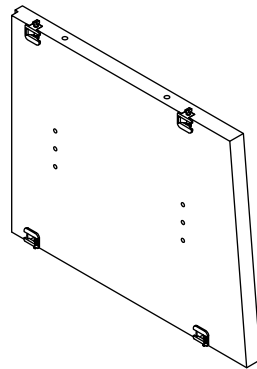

(6) RIGHT SIDE PANEL (1 PC)

PARTS LIST

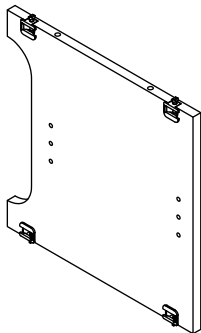

(7) MIDDLE DIVIDER (1 PC)

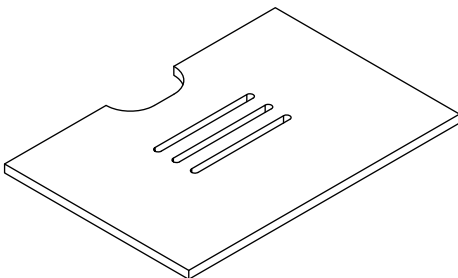

(8) ADJUSTABLE SHELF (2 PCS)

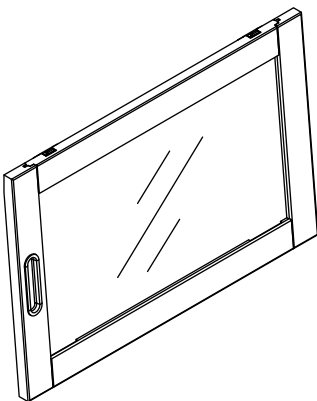



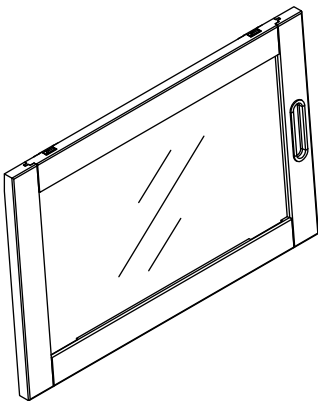

(9) LEFT DOOR (1 PC)

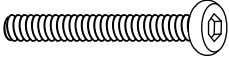

(10) RIGHT DOOR (1 PC)

HARDWARE LIST

NO	SKETCH	DESCRIPTION	SIZE	Q'TY
A		BOLT	ø1/4" X 1-3/4"	4 PCS+ 1 EXTRA
B		SPRING WASHER	ø1/4"	4 PCS+ 1 EXTRA
C		FLAT WASHER	ø1/4" X 12 mm	4 PCS+ 1 EXTRA
D		WRENCH	4 mm	1 PC
E		WOOD DOWEL	ø8 X 30 mm	12 PCS+ 2 EXTRA
F		SCREW	ø3 X 15 mm	24 PCS+ 3 EXTRA
G		SHELF SUPPORT		8 PCS+ 2 EXTRA

OPTION #1

STEP 1

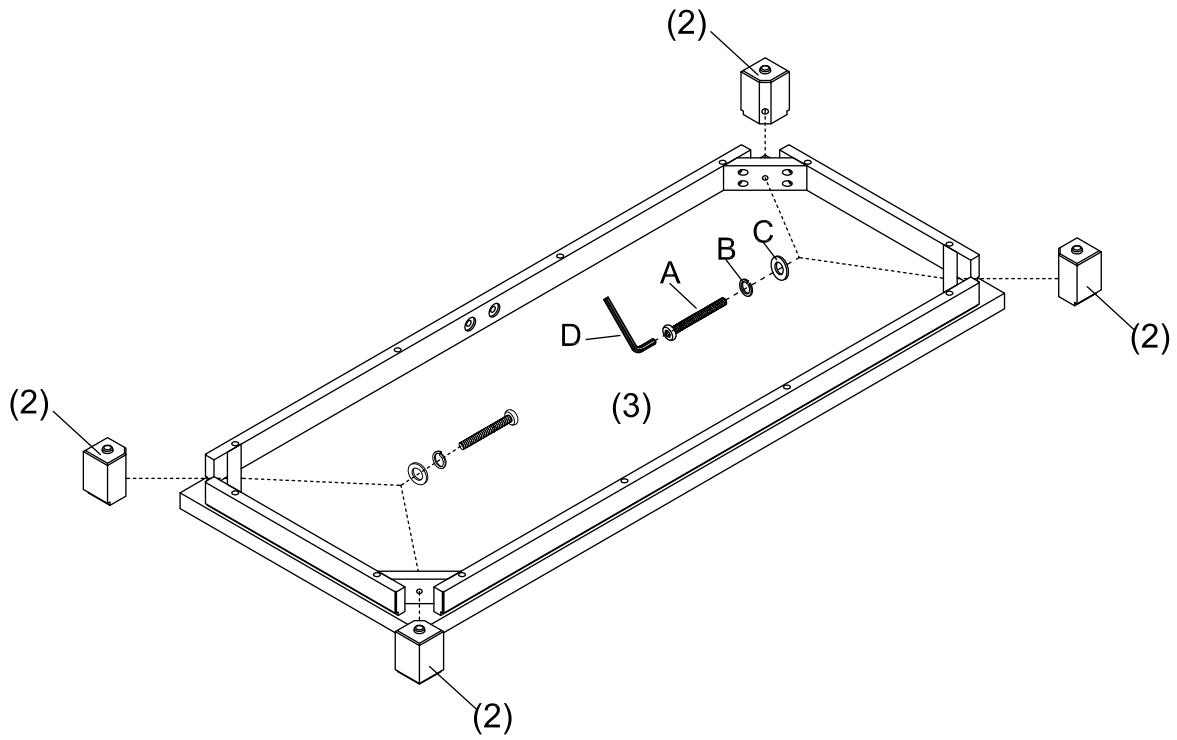

STEP 2

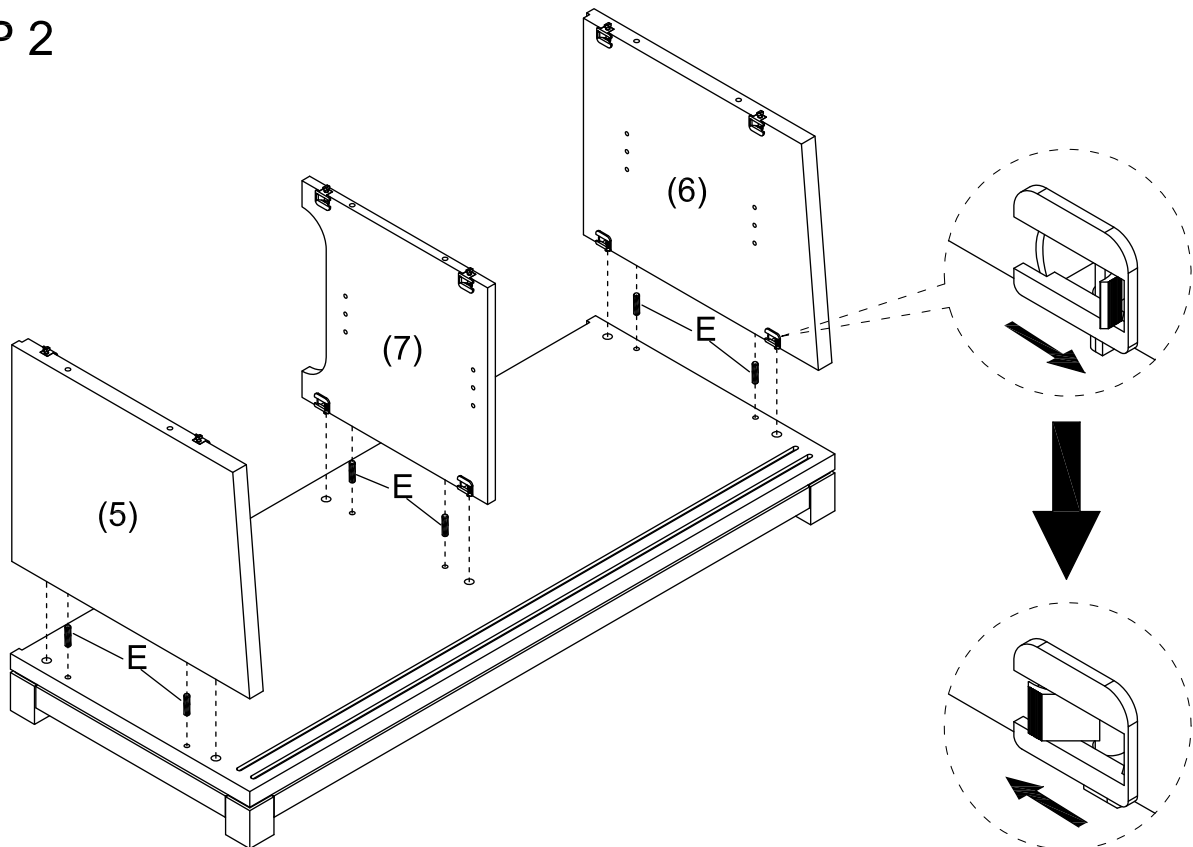

STEP 3

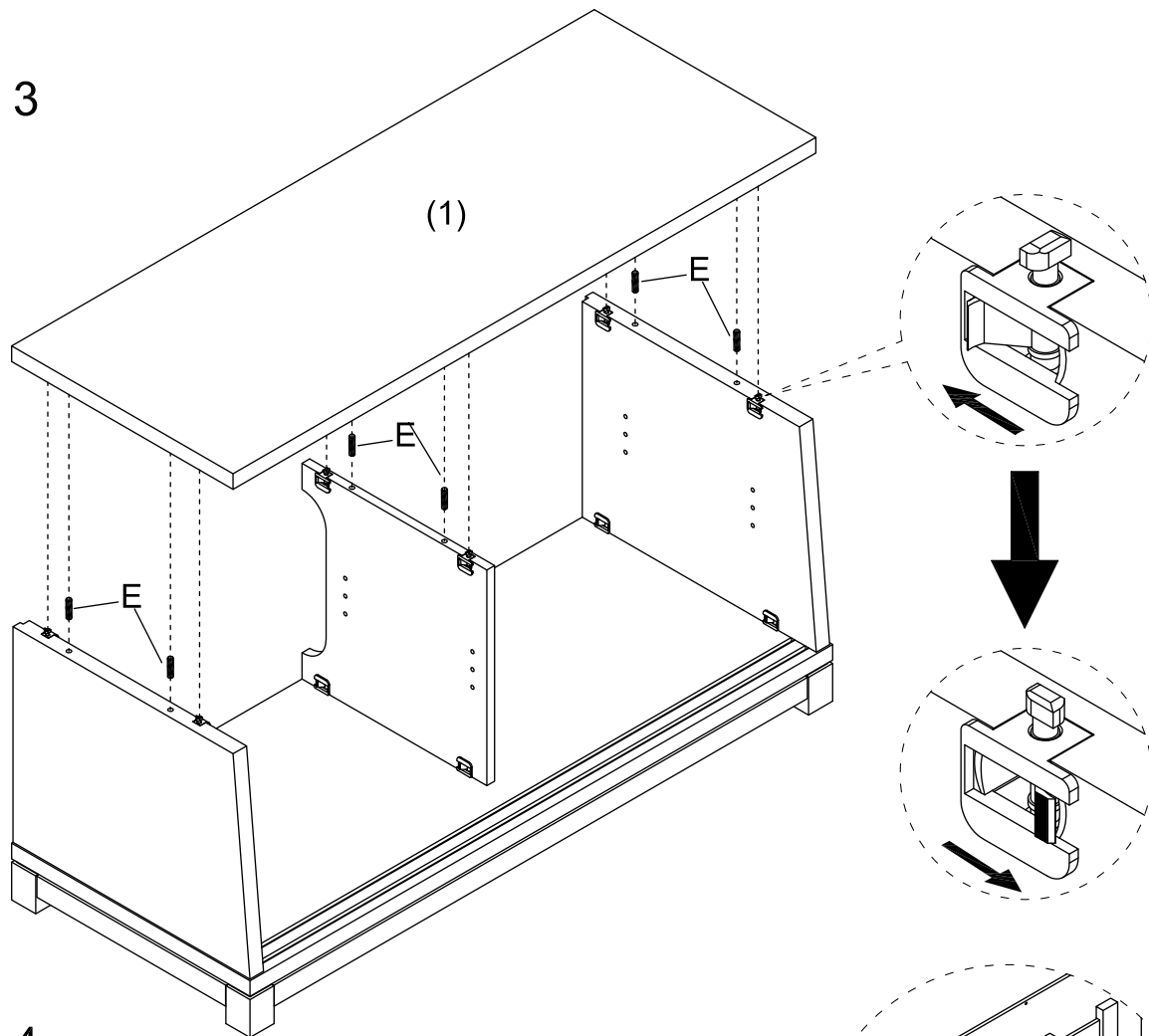

STEP 4

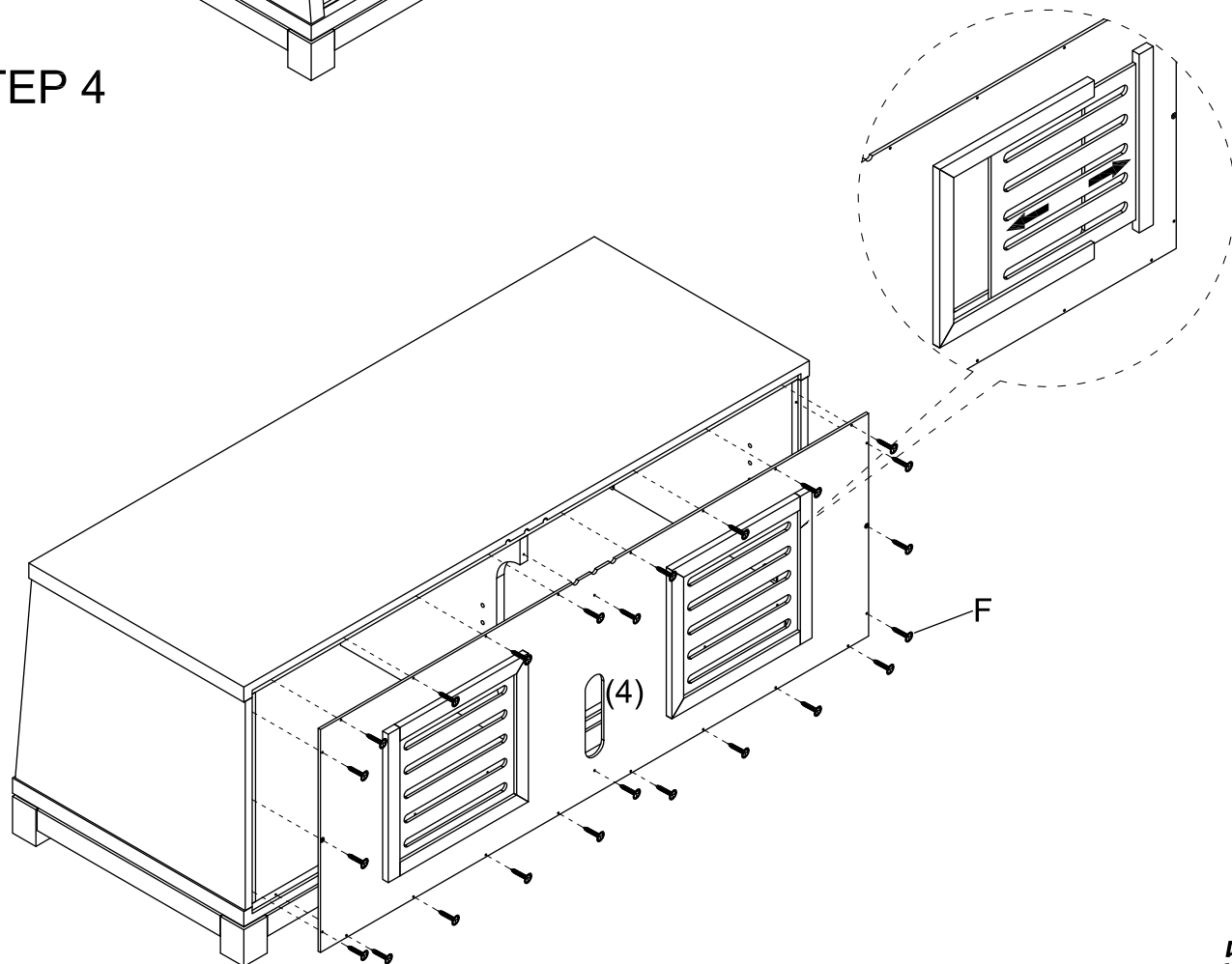

STEP 5

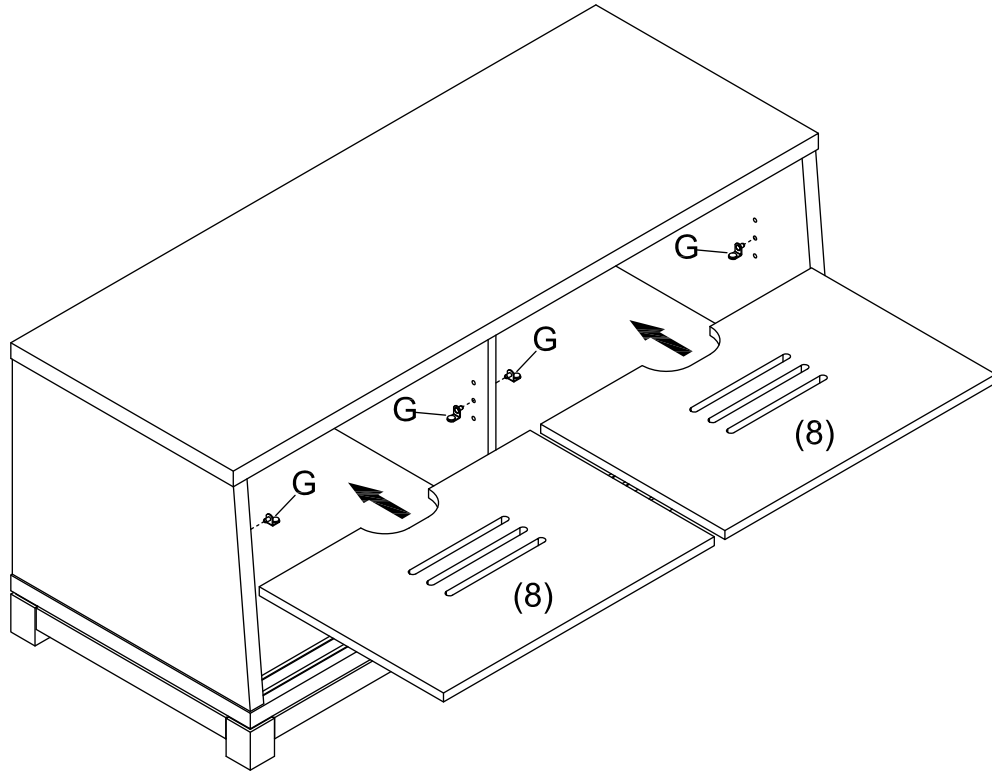

STEP 6

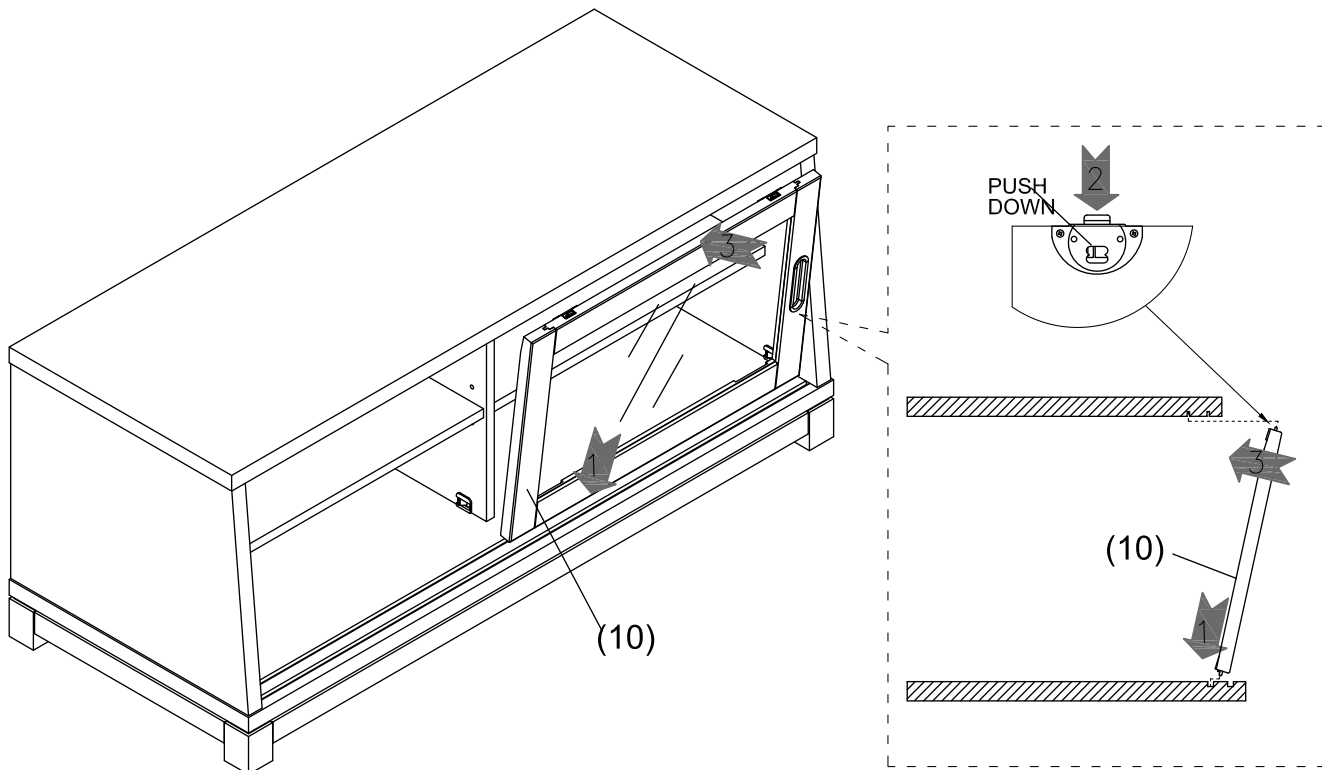

STEP 7

