

CK394200TX

Orinda End Table

Assembly Instructions



**Southern
ENTERPRISES**

For assistance with assembly, contact.
Southern Enterprises Inc.
Customer Service: 1-800-633-5096
service@seidal.com
www.seidal.com

PO:13454

Top supports up to lb.

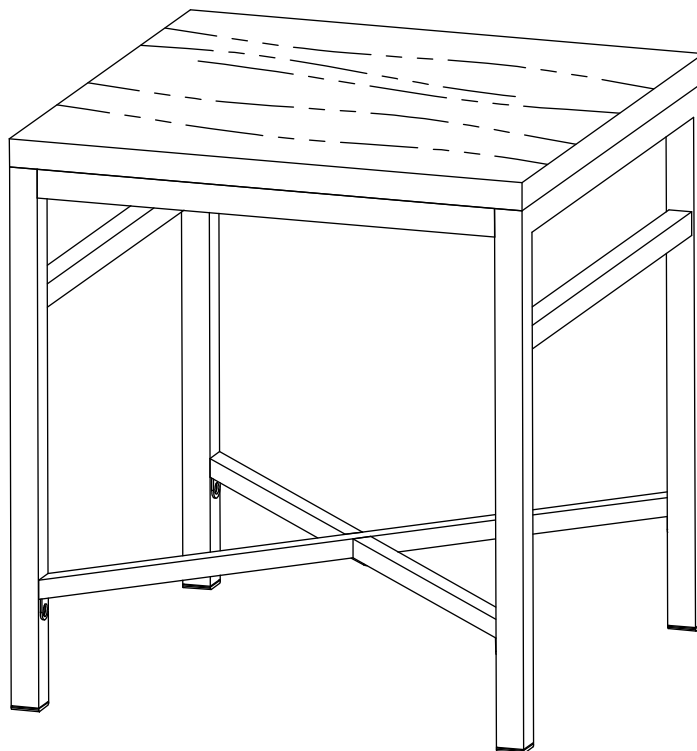

CK394200TX

Orinda End Table

Parts List

Please review all parts and hardware before disposing of any packaging.

Before beginning assembly, separate each type of hardware. Carefully study the diagrams below.

Call Customer Service if missing hardware. Using the incorrect hardware will cause damage.

You may receive extra hardware with your unit.

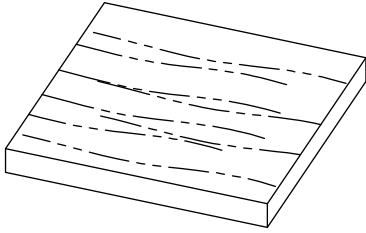
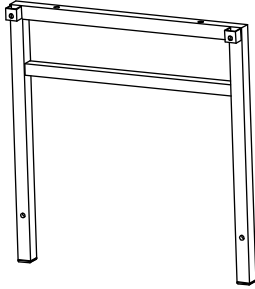
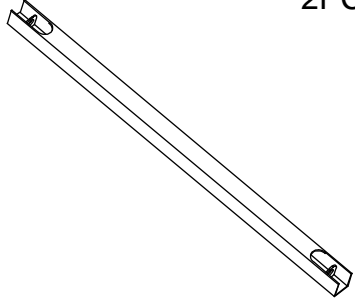
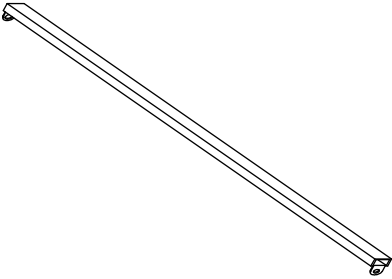
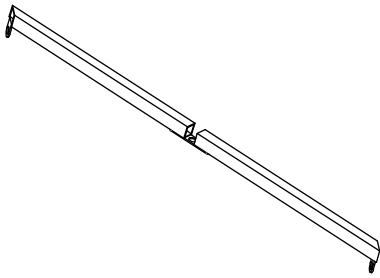
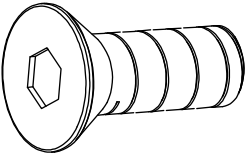
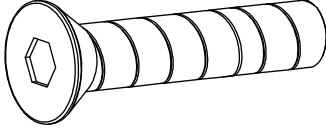
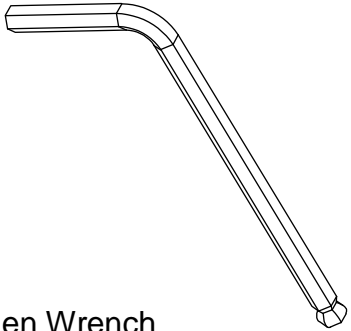
<p>1 1PC</p>  <p>Wood Top</p>	<p>2 2PCS</p>  <p>Side Panels</p>	<p>3 2PCS</p>  <p>Stretchers</p>
<p>4 1PC</p>  <p>X-Frame Top Stretcher</p>	<p>5 1PC</p>  <p>X-Frame Bottom Stretcher</p>	
<p>A 9PCS</p>  <p>Short Bolts 1/4"x5/8"</p>	<p>B 4PCS</p>  <p>Long Bolts 1/4"x1-1/2"</p>	<p>C 1PC</p>  <p>Allen Wrench</p>
<p>Care and Cleaning Instructions: Before using, wipe with a clean, dry cloth. Avoid rubbing or scratching the surface with rough or abrasive objects.</p>		<p>For replacement parts or questions, please call customer service at 1-800-633-5096.</p>

CK394200TX

Orinda End Table

Assembly Instructions

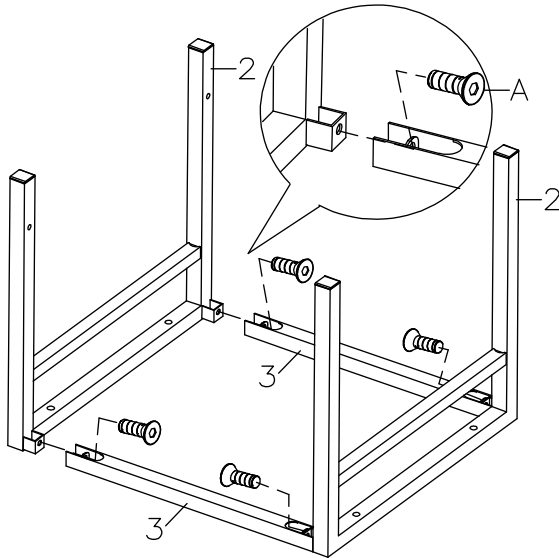

Figure 1

Step 1:

Unit assembly should begin with parts turned upside down for Step 1.

Attach Stretchers (3) to Side Panels (2) using Short Bolts (A) as shown. Tighten Bolts with Allen Wrench (C).

Note: Do not fully tighten Bolts until Step 3 is complete.

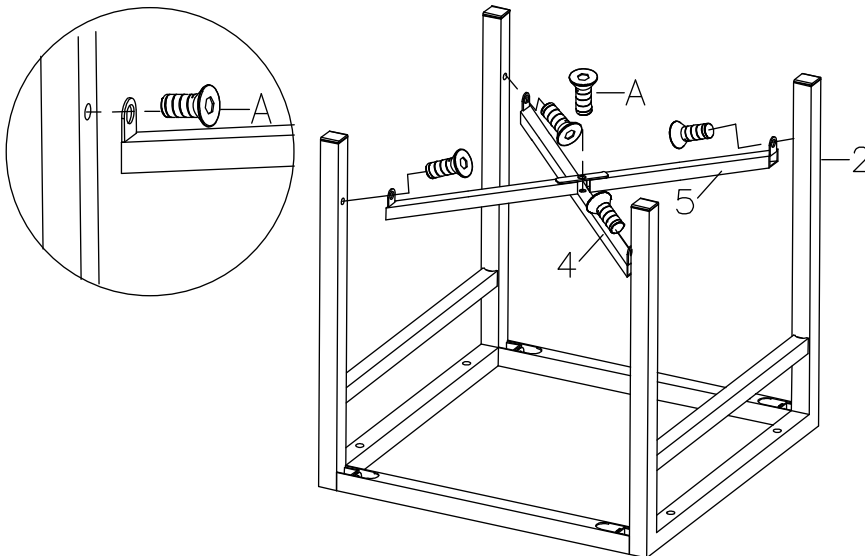

Figure 2

Step 2:

Attach X-Frame Bottom Stretcher (5) to X-Frame Top Stretcher (4) using Short Bolts (A).

Then, attach assembled X-Frame to Side Panels (2) using Short Bolts (A).

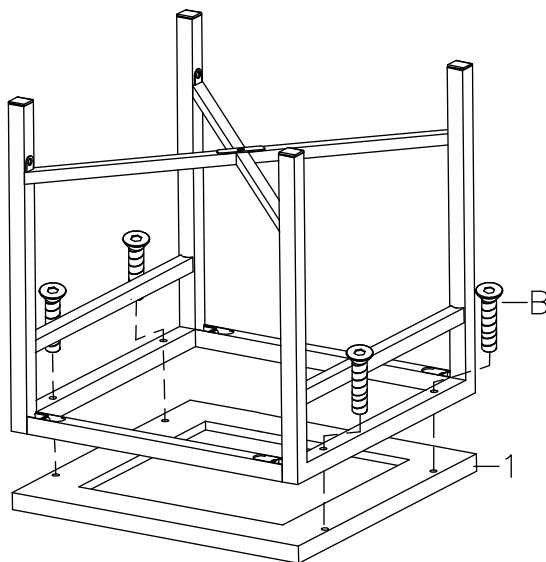

Figure 3

Step 3:

Attach assembled metal frame to Wood Top **(1)** using Long Bolts **(B)** as shown.

Fully tighten all bolts with Allen Wrench **(C)**.

Turn assembled unit upright.

Your Orinda End Table is now complete!

Parts Replacement Form

Customer Information

Name _____

Address _____

City/State/Zip Code _____

Phone Number _____

Please indicate where you purchased this item: Store/Website/Catalog

Please indicate color/size/style number:

Style No	Parts Letter	Parts Description	Quantity Needed
_____	_____	_____	_____
_____	_____	_____	_____
_____	_____	_____	_____

Please immediately examine this product carefully. Any request for missing parts or damage replacement must be received within 90 days of your receipt of the product. Replacement, if available, will be honored within this time frame. Parts will not be available for items arriving fully assembled. We do not recommend modifying product(s) and we are not responsible for any damages due to product modification(s). If damages or missing parts are not reported within 90 days of your receipt, we are under no obligation to provide parts or replacement merchandise.

For product issues, please contact Southern Enterprises at 800-633-5096 (toll-free) / 972-869-0111 (Dallas), Mon-Fri 9am – 4pm CST, or email us at service@seidal.com. Please ask for customer service representative for issues involving damages or replacement parts. Please ask for technical assistance representative for any issues with product and assembly/construction.

Please contact the retailer that you purchased from for returns.



Southern
ENTERPRISES

Customer Service: 1-800-633-5096
service@seidal.com

Southern Enterprises, Inc.
600 Freeport Parkway, Suite 200
Coppell, Texas 75019