

BC402800TX

**Larimore Drawer/Basket  
Storage Bench - Black**

**Assembly Instructions**



**Southern  
ENTERPRISES**

For assistance with assembly contact:

Southern Enterprises Inc.

Customer Service 1-800-633-5096

[service@seidal.com](mailto:service@seidal.com)

[www.seidal.com](http://www.seidal.com)

PO#:

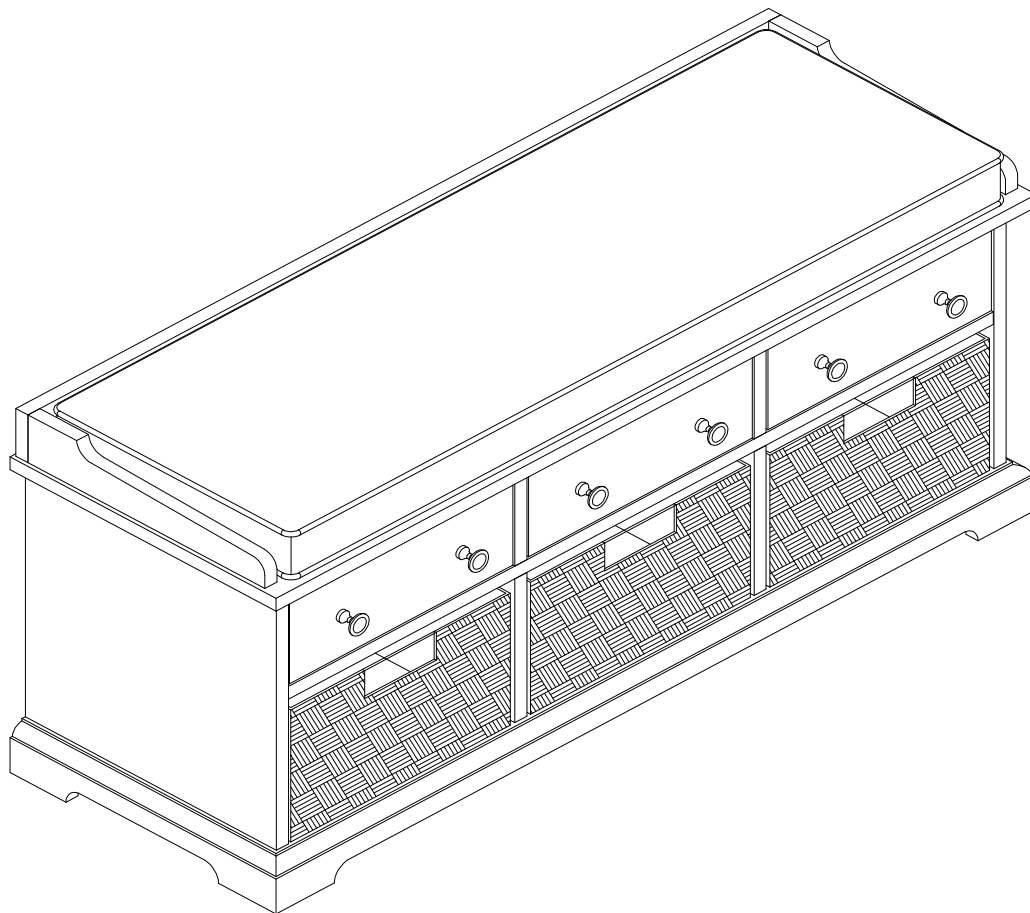







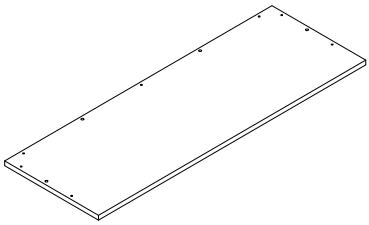
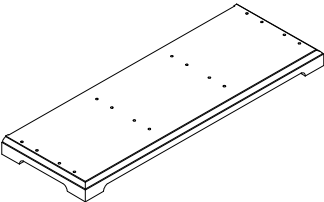
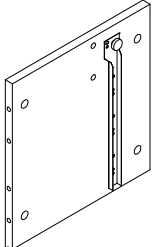
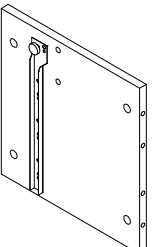
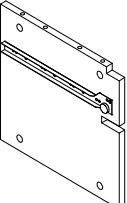
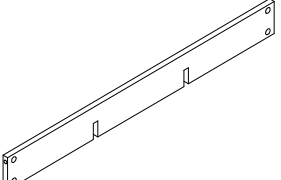
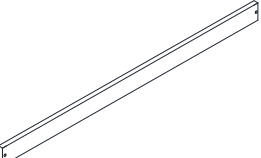
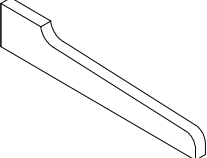
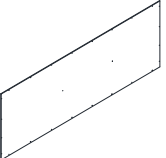
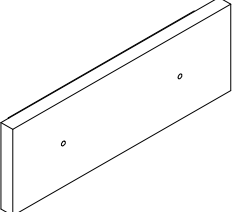
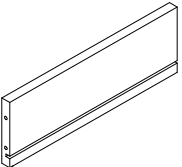
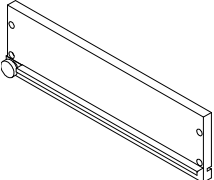

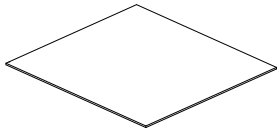
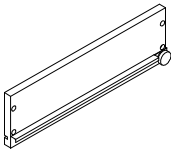
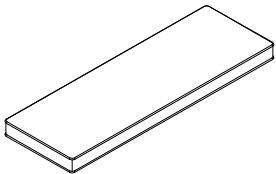
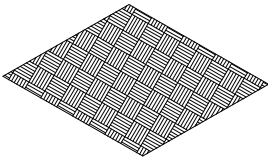
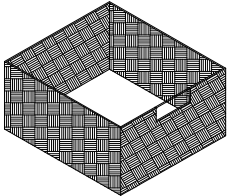
# Larimore Black Bench W/Drawer/Basket Storage

## Parts List

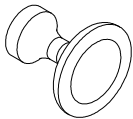
Please check packaging for all parts and hardware before discarding. Unpack and lay parts on clean, padded surface like carpet or blanket. Check that you have all parts indicated. Call customer service if hardware is missing. Before beginning assembly, carefully study the diagrams below and sort your hardware according to the pictures. Using the incorrect hardware will cause damage.

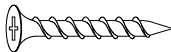
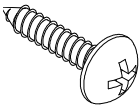
<p>1</p> <p>Quantity of 1</p>  <p>Top Panel</p>	<p>2</p> <p>Quantity of 1</p>  <p>Bottom Frame</p>	<p>3</p> <p>Quantity of 1</p>  <p>Left Side Panel</p>
<p>4</p> <p>Quantity of 1</p>  <p>Right Side Panel</p>	<p>5</p> <p>Quantity of 2</p>  <p>Middle Panel</p>	<p>6</p> <p>Quantity of 1</p>  <p>Cross Panel</p>
<p>7</p> <p>Quantity of 1</p>  <p>Baffle</p>	<p>8</p> <p>Quantity of 2</p>  <p>Side Baffle</p>	<p>9</p> <p>Quantity of 1</p>  <p>Back Panel</p>
<p>10</p> <p>Quantity of 3</p> <p>Color 1 Color 2 Color 3</p>  <p>Drawer Face Panel</p>	<p>11</p> <p>Quantity of 3</p>  <p>Drawer Back Panel</p>	<p>12</p> <p>Quantity of 3</p>  <p>Left Drawer Side Panel</p>

<p>13 Quantity of 3</p>  <p>Drawer Bottom Panel</p>	<p>14 Quantity of 3</p>  <p>Right Drawer Side Panel</p>	<p>15 Quantity of 1</p>  <p>Cushion</p>
<p>16 Quantity of 3</p>  <p>Basket Bottom</p>	<p>17 Quantity of 3</p>  <p>Basket Frame</p>	
<p>A Quantity of 20</p>  <p>Cam Bolt</p>	<p>B Quantity of 20</p>  <p>Cam Lock</p>	<p>C Quantity of 23</p>  <p>Wood Dowel Dia 8mm x 30mm</p>
<p>D Quantity of 6</p>  <p>Handle</p>	<p>E Quantity of 6</p>  <p>Bolt Dia 5/32" x 1-1/4"L</p>	<p>F Quantity of 34</p>  <p>Screw Dia 1/8" x 1"L</p>
<p>G Quantity of 20</p>  <p>Pan Head Screw Dia 1/8" x 1/2"L</p>	<p>H Quantity of 8</p>  <p>Adhesive Pad</p>	

**Care and Cleaning Instructions:**  
 Before using, wipe with a clean, dry cloth. Periodically apply furniture wax to renew the finish. Avoid rubbing or scratching the surface with rough or abrasive objects.

For replacement parts or questions, please call Customer Service at 1-800-633-5096.

**Assembly Tool Required  
 No.2 Phillips Screwdriver  
 (Not Included)**

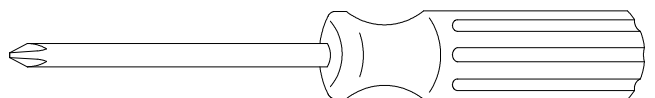

# Larimore Drawer/Basket Storage Bench - Black

## Assembly Instructions

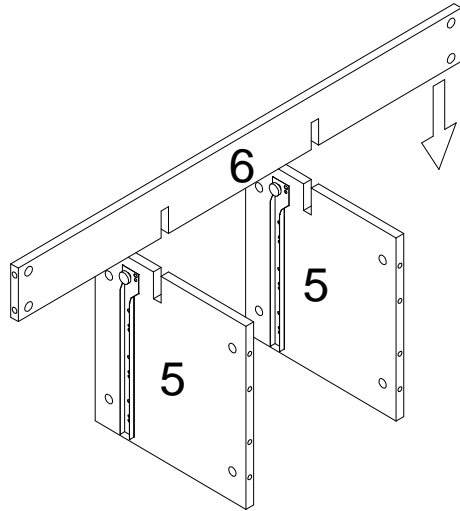

Insert Cross Panel (6) into grooves on Middle Panel (5), as shown.

Figure 1

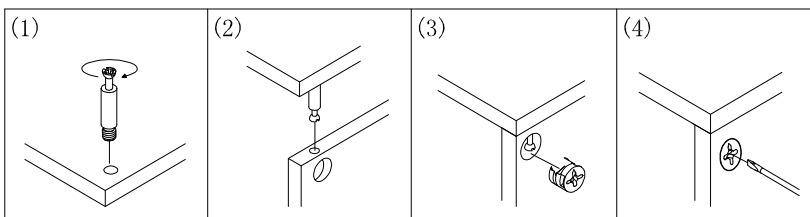

Start turning with finger to help align Cam Bolts.

Insert Cam Locks (B) into holes on Cross Panel (6).

"Please do not over tighten cambolts. Please stop when you feel tight"

Screw Cam Bolts (A) into holes on Left Side Panel (3) and Right Side Panel (4).

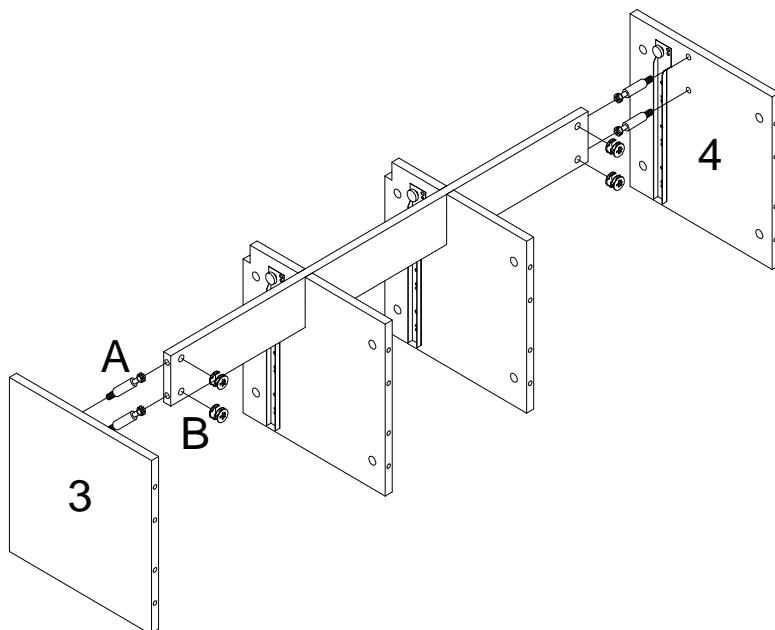

Attach assembled unit on Figure 1 to Left Side Panel (3) and Right Side Panel (4) by inserting Cam Bolts (A) into corresponding holes until all panels meet.

Tighten by rotating Cam Locks (B) clockwise with Phillips screwdriver.

Figure 2

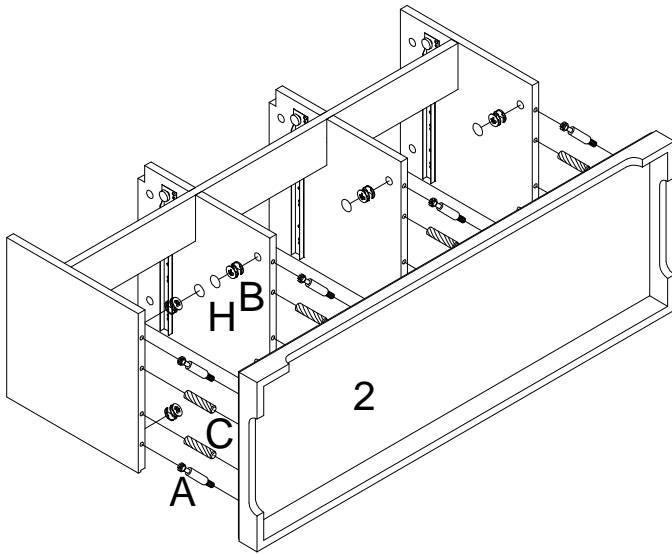

Start with finger to help align Cam Bolts.

Insert Cam Locks **(B)** into holes on assembled unit on Figure 2.

Screw Cam Bolts **(A)** into holes on the top side of Bottom Frame **(2)**.

Attach assembled unit on Figure 2 to Bottom Frame **(2)** by inserting Cam Bolts **(A)** and Wood Dowels **(C)** into corresponding holes until all panels meet.

Tighten by rotating Cam Locks **(B)** clockwise with Phillips screwdriver.

Cover Cam Locks **(B)** with Adhesive Pads **(H)** provided.

Figure 3

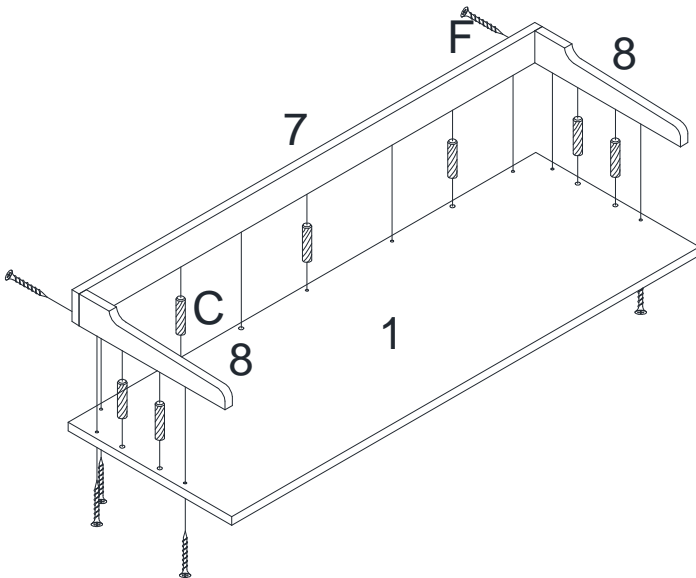

Start with finger to help align Machine Screws.

Attach Baffle **(7)** to Side Baffles **(8)** with Screws **(F)**.

Connect Baffle **(7)** and Side Baffles **(8)** to Top Panel **(1)** with Screws **(F)** and Wood Dowels **(C)**.

Tighten Screws **(F)** with Phillips screwdriver.

Figure 4

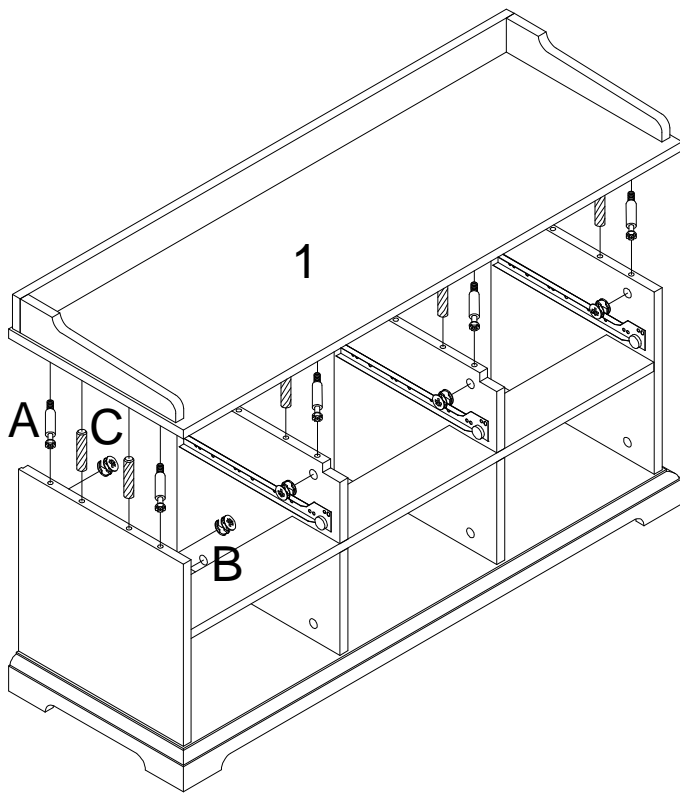

Figure 5

Start with finger to help align Cam Bolts.

Insert Cam Locks **(B)** into holes on assembled unit on Figure 4.

Screw Cam Bolts **(A)** into holes on Top Panel **(1)**.

Attach Top Panel **(1)** to assembled unit on Figure 4 by inserting Wood Dowels **(C)** and Cam Bolts **(A)** into corresponding holes until all panels meet.

Tighten by rotating Cam Bolts **(A)** clockwise with Phillips screwdriver.

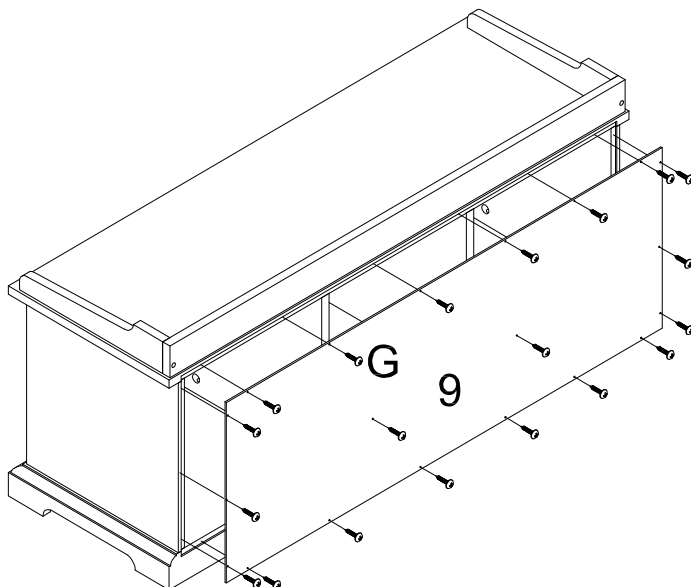
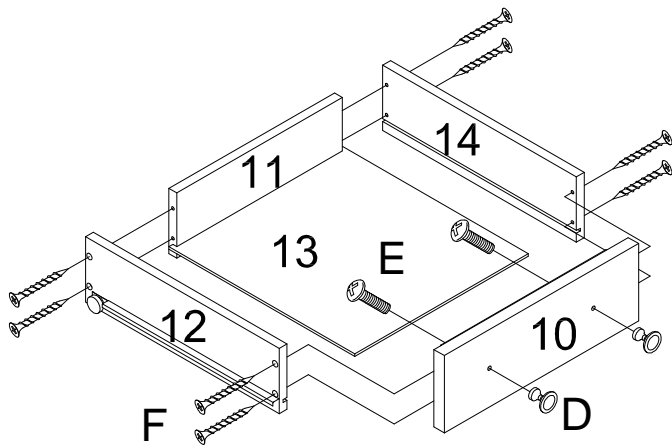

Figure 6

Start with finger to help align Screws.

Attach Back Panel **(9)** on assembled unit with Screws **(G)**.

Tighten Screws **(G)** with Phillips screwdriver.



Start with finger to help align Screws.

Attach Left Drawer Side Panels (12), Right Drawer Side Panels (14) and Drawer Back Panels (11) with Screws (F).

Insert Drawer Bottom Panels (13) into grooves of Drawer Panels (11), (12), and (14).

Attach Drawer Face Panels (10) to assembled drawers using Screws (F).

Finally, attach Handles (D) to Drawer Face Panels (10) using Bolts (E).

Tighten screws and bolts with Phillips screwdriver.

Figure 7

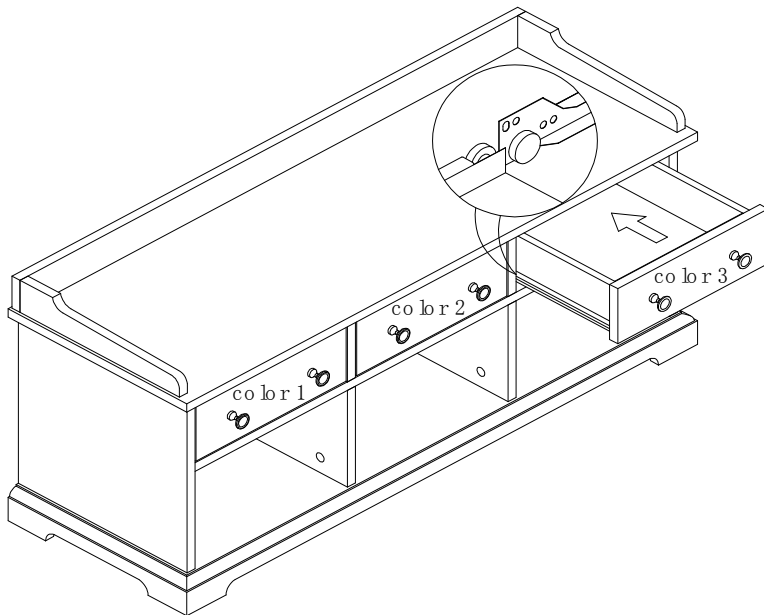

Insert drawers into their corresponding places, assuring the glides ride smoothly.

Figure 8

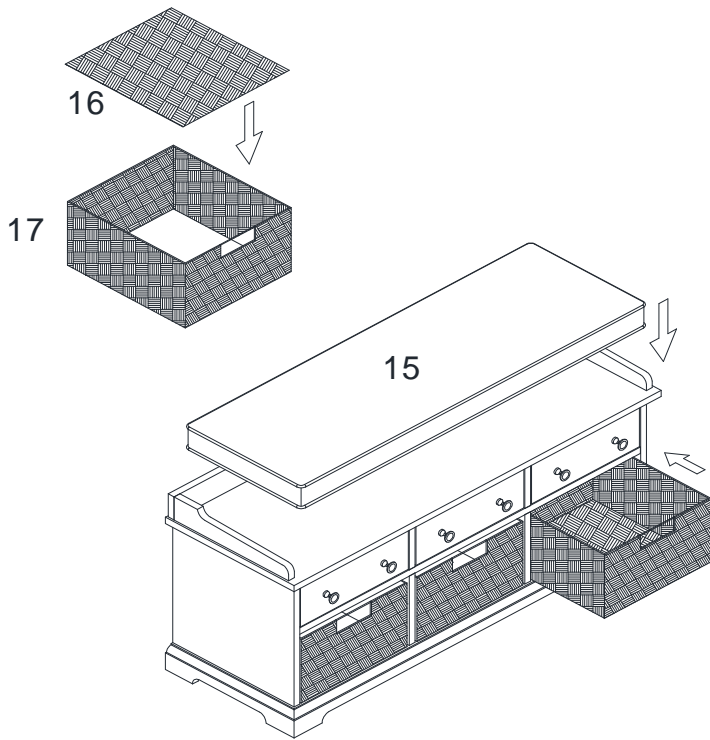

Figure 9

Attach Basket Bottoms (16) into Basket Frames (17).

Insert Baskets into their corresponding spaces.

Place the Cushion (15) onto the top panel.

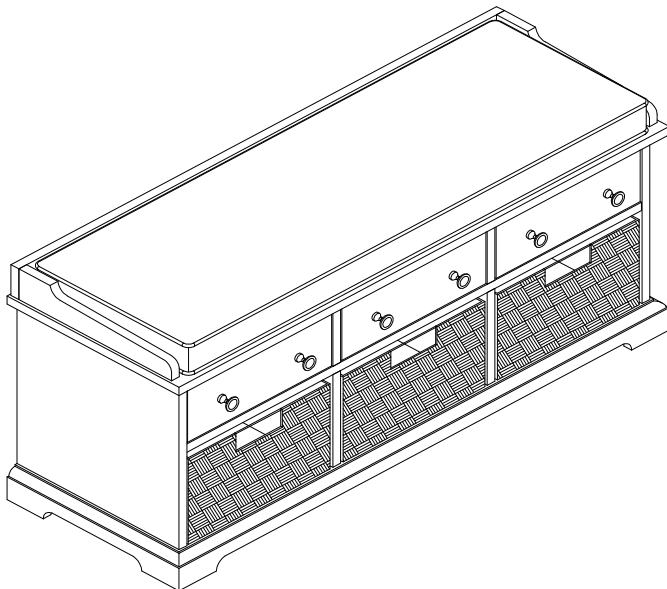

Figure 10

Now your Larimore Drawer/Basket Storage Bench is ready to use.



# Parts Replacement Form

## Customer Information

Name \_\_\_\_\_

Address \_\_\_\_\_

City/State/Zip Code \_\_\_\_\_

Phone Number \_\_\_\_\_

Please indicate where you purchased this item: Store/Website/Catalog

\_\_\_\_\_

Please indicate color/size/style number:

\_\_\_\_\_

Style No	Parts Letter	Parts Description	Quantity Needed
_____	_____	_____	_____
_____	_____	_____	_____
_____	_____	_____	_____

Please immediately examine this product carefully. Any request for missing parts or damage replacement must be received within 90 days of your receipt of the product. Replacement, if available, will be honored within this time frame. Parts will not be available for items arriving fully assembled. We do not recommend modifying product(s) and we are not responsible for any damages due to product modification(s). If damages or missing parts are not reported within 90 days of your receipt, we are under no obligation to provide parts or replacement merchandise.

For product issues, please contact Southern Enterprises at 800-633-5096 (toll-free) / 972-869-0111 (Dallas) Mon-Fri 9am – 4pm CST, or email us at [service@seidal.com](mailto:service@seidal.com). Please ask for customer service representative for issues involving damages or replacement parts. Please ask for technical assistance representative for any issues with product and assembly/construction.

Please contact the retailer that you purchased from for returns.



**Southern**  
ENTERPRISES

Customer Service: 1-800-633-5096  
[service@seidal.com](mailto:service@seidal.com)

Southern Enterprises, Inc.  
600 Freeport Parkway, Suite 200  
Coppell, Texas 75019