

CK754000TX

“Prentice” Cocktail Table  
Assembly Instruction



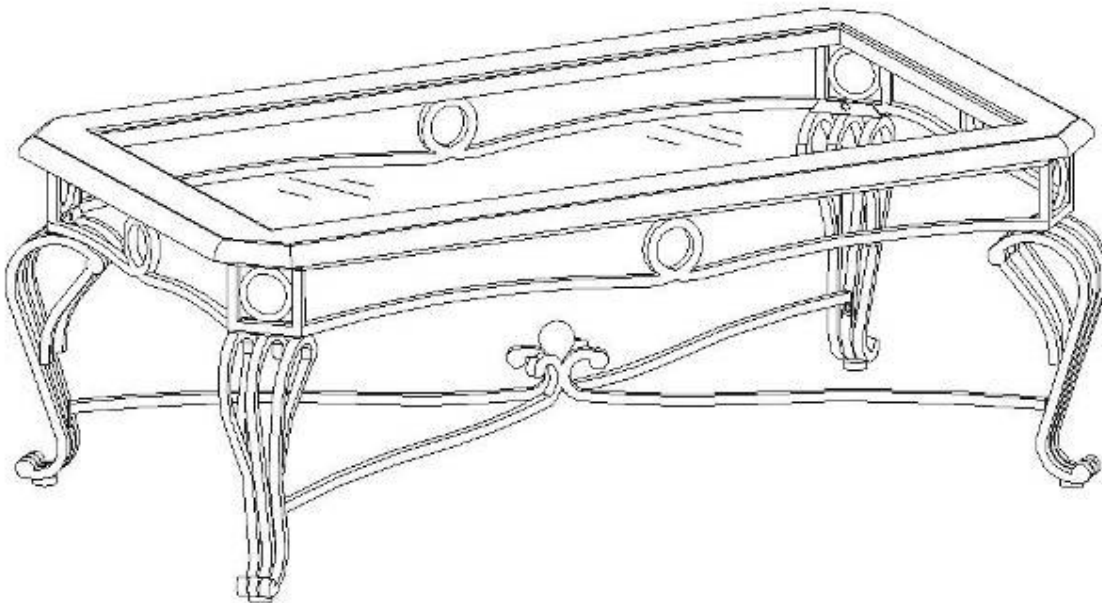

For assistance with assembly contact:  
Southern Enterprises Inc.  
Customer Service 1-800-633-5096  
[service@seidal.com](mailto:service@seidal.com)  
[www.seidal.com](http://www.seidal.com)

**Max top load 40 lb.**

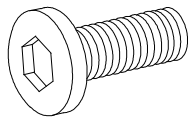
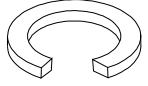
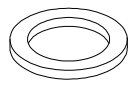
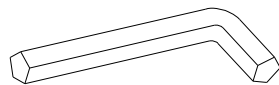
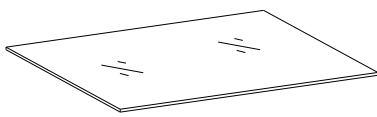
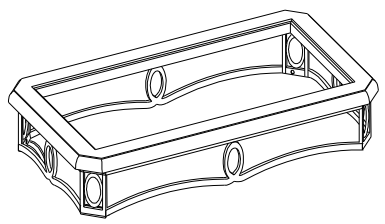

# CK754000TX "Prentice" Cocktail Table Parts List

Please review all parts and hardware before disposing of any packaging.  
Call Customer Service if missing hardware. Do not return to store/retailer.  
Screws shown actual size. Using a screw that is too long will cause damage.  
Before beginning assembly, separate each type of screw. Carefully study  
the screw diagrams below (SHOWN ACTUAL SIZE).

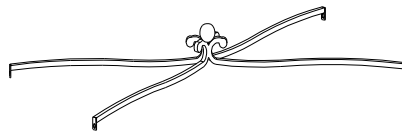
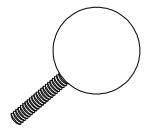
<p><b>A</b> <span style="float: right;">16PCS</span></p>  <p>Screw</p>	<p><b>B</b> <span style="float: right;">16PCS</span></p>  <p>Lock Washer</p>	<p><b>C</b> <span style="float: right;">16PCS</span></p>  <p>Flat Washer</p>
<p><b>D</b> <span style="float: right;">1PC</span></p>  <p>Wrench</p>	<p><b>E</b> <span style="float: right;">1PC</span></p>  <p>Glass</p>	<p><b>F</b> <span style="float: right;">1PC</span></p>  <p>Top Frame</p>
<p><b>G</b> <span style="float: right;">4PCS</span></p>  <p>Leg</p>	<p><b>H</b> <span style="float: right;">1PC</span></p>  <p>Bottom Stretcher</p>	<p><b>I</b> <span style="float: right;">1PC</span></p>  <p>Finial</p>

**Care and Cleaning Instructions:**

Before using, wipe with a clean, dry cloth.  
Periodically apply furniture wax to renew  
The finish. Avoid rubbing or scratching the  
surface with rough or abrasive objects.

For replacement parts or questions, please  
call Customer Service at 1-800-633-5096.  
Do not return product to store. Please call  
manufacturer for assistance, questions or  
parts.

# CK754000TX "Prentice" Cocktail Table Assembly Instructions

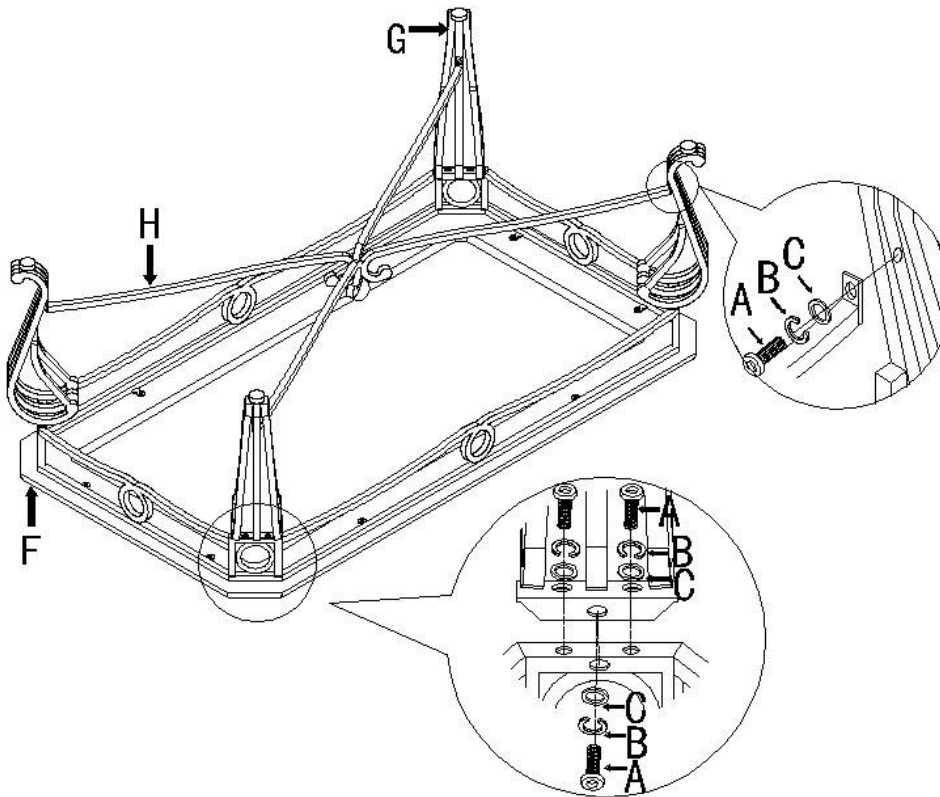

Step 1. Put all parts on a soft surface to prevent scratches.

Attach leg (G) to top frame (F) by using screw (A), lock washer (B), flat washer (C) as shown.

Then attach bottom stretcher (H) to legs (G) by using screw (A), lock washer (B), flat washer (C) as shown.

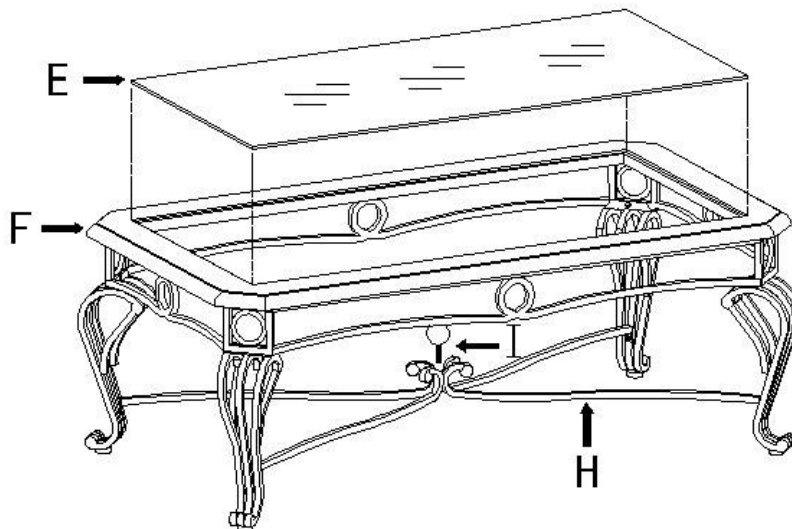

Step 2. Turn the unit up side down, put on glass (E) and screw finial ( I ) as shown.



Customer Service 1-800-633-5096  
service@seidal.com  
Southern Enterprises, Inc.  
2915 Merrell Road  
Dallas, Texas 75229

**We'd love to hear from you! Email us photos of our products in your home at [sei@seidal.com](mailto:sei@seidal.com) and we might feature it on our site or use it to model one of our inspirational photos.**

**“ PARTS WILL BE SENT IF AVAILABLE FORM SEI “**

## Parts Replacement Form

### Customer Information

Name \_\_\_\_\_

Address \_\_\_\_\_

City/State/Zip Code \_\_\_\_\_

Phone Number \_\_\_\_\_

Please indicate where you purchased this item: Store/ Website/ Catalog

Please indicate color/size/style number:

Style No	Parts Letter	Parts Description	Quantity Needed

Missing or damaged hardware and/ or parts will be replaced free of charge. We do not sell parts. Southern Enterprises Inc. will provide replacement parts for only those items purchased within the last 9 months. If this product has not been purchased from our retail affiliates (within 9 months), we are under no obligation to provide parts or replacements merchandise. Parts will not be available for items arriving fully assembled.



Customer Service 1-800-633-5096

[service@seidal.com](mailto:service@seidal.com)

Southern Enterprises, Inc.

2915 Merrell Road

Dallas, Texas 75229