

CK222400TX

Espresso Pyramid Cocktail Table  
Assembly Instructions



For assistance with assembly contact:  
Southern Enterprises Inc.  
Customer Service 1-800-633-5096  
service@seidal.com  
www.seidal.com

PO#11703

Max Top Load 80 lbs.

Max Load Inside the Trunk 100 lbs.

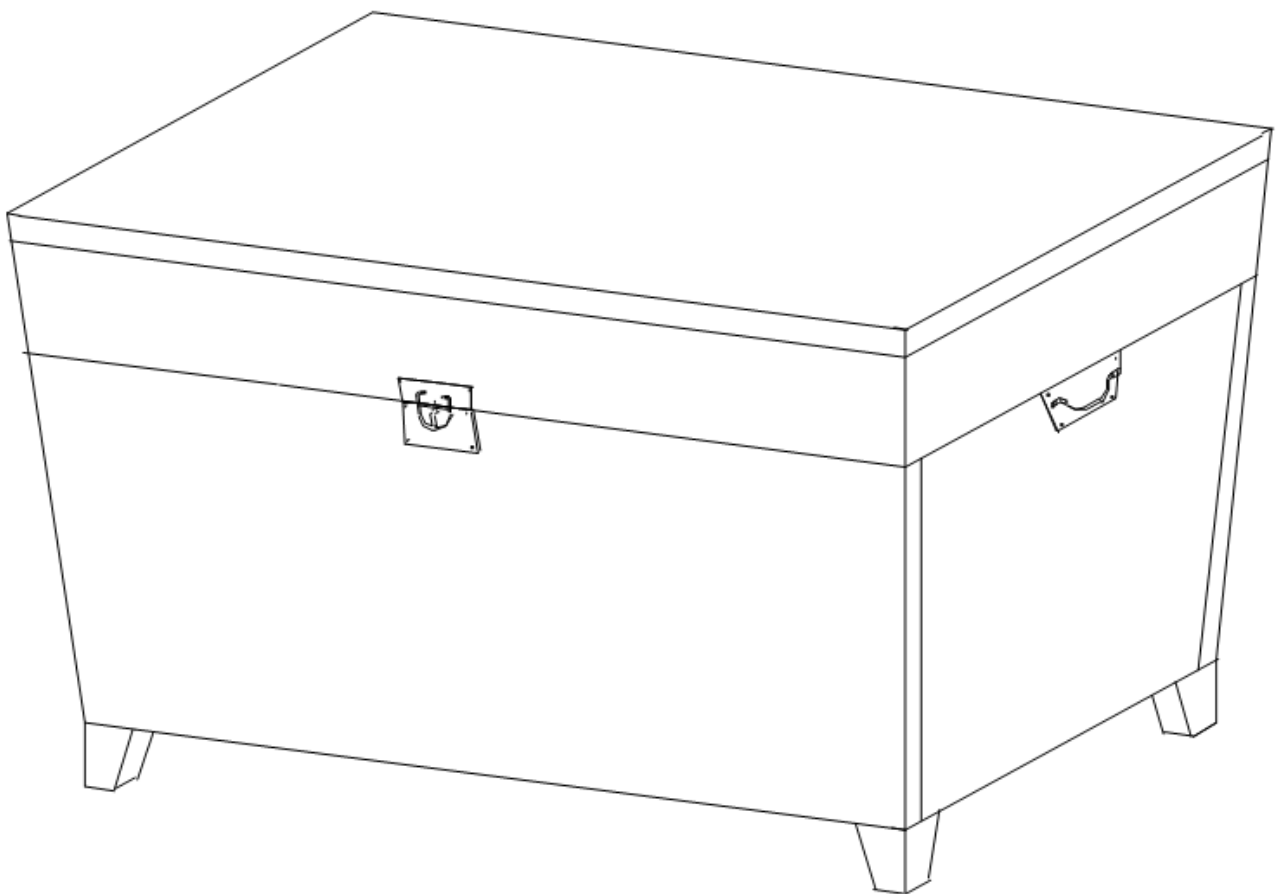

# CK222400TX

## Espresso Pyramid Cocktail Table

### Parts List

Please review all parts and hardware before disposing of any packaging. Call Customer Service if missing hardware. Do not return to store/retailer. Using a screw that is too long will cause damage. Before beginning assembly, separate each type of screw. Carefully study the screw diagrams below.

A

1 PC

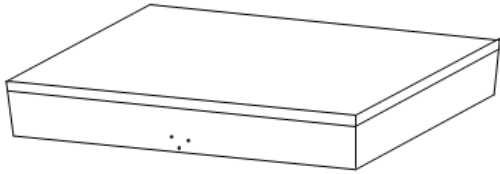

Top

B

1 PC

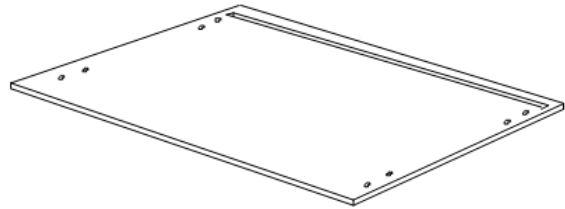

Front Panel

C

1 PC

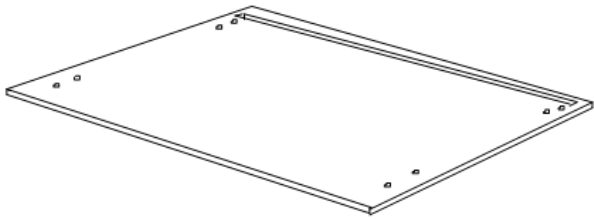

Back Panel

D

1 PC

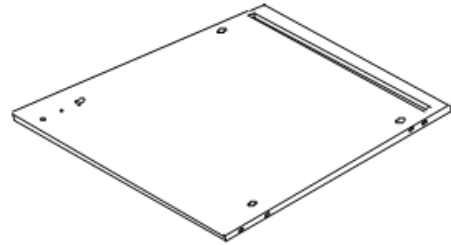

Left Side Panel

E

1 PC

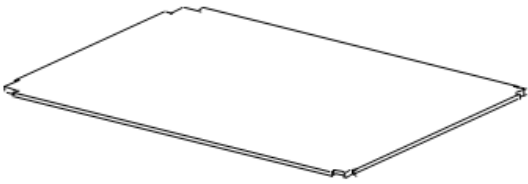

Bottom Panel

F

4 PCS

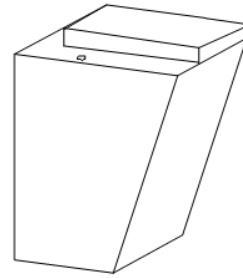





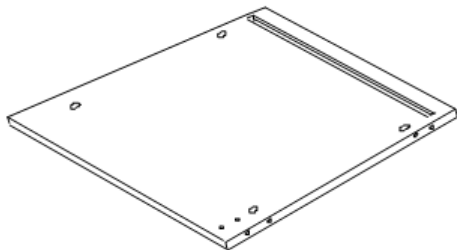

Leg

G

1 PC

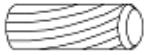

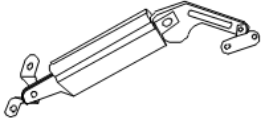
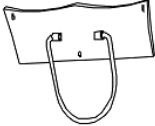
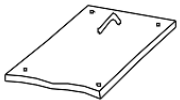
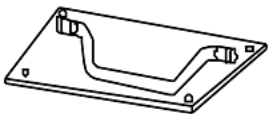
Right Side Panel

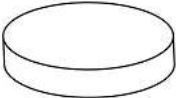
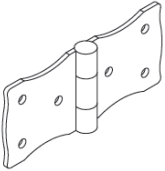
<p><b>H</b> 8 PCS</p>  <p>Small Cam Screw φ6.8 x 36mm</p>	<p><b>I</b> 8 PCS</p>  <p>Small Cam Lock φ15 x 12mm</p>	<p><b>J</b> 1 PC</p>  <p>Wrench</p>
<p><b>K</b> 8 PCS</p>  <p>Dowel φ8 x 30mm</p>	<p><b>L</b> 8 PCS</p>  <p>Bolt φ 1/4" x 2 3/4"</p>	<p><b>M</b> 35 PCS</p>  <p>Screw φ 3.5 x 16mm</p>
<p><b>N</b> 1 PC</p>  <p>Left-Support</p>	<p><b>O</b> 1 PC</p>  <p>Handle-A</p>	<p><b>P</b> 1 PC</p>  <p>Handle-B</p>
<p><b>Q</b> 2 PCS</p>  <p>Handle</p>	<p><b>R</b> 1 PC</p>  <p>Right Support</p>	<p><b>S</b> 10 PCS</p>  <p>Sponge Cushion</p>
<p><b>T</b> 2 PCS</p>  <p>Hinge</p>		

**Care and Cleaning Instructions:**

Before using, wipe with a clean dry cloth. Periodically apply furniture wax to renew the finish. Avoid rubbing or scratching the surface with rough or abrasive objects.

For replacement parts or questions, please call Customer Service at 1-800-633-5096. Do not return product to store. Please call manufacturer for assistance, questions or parts.

**Assembly Tool Required**  
**No.2 Phillips Screwdriver**

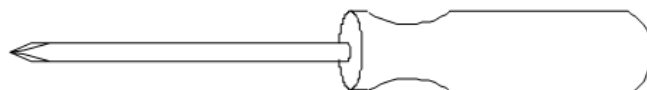

**CK222400TX**  
**Espresso Pyramid Cocktail Table**  
**Assembly Instructions**

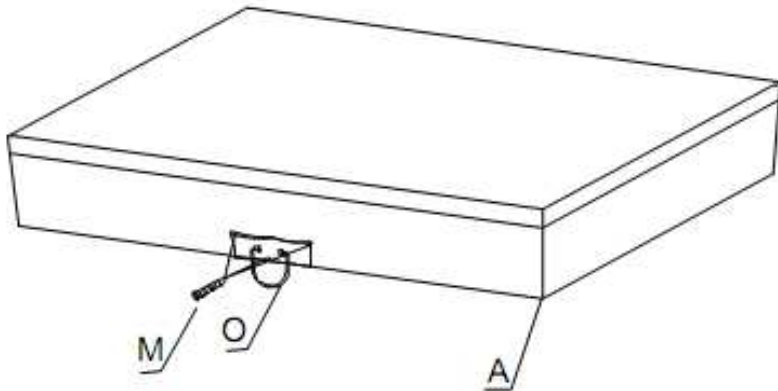

**PLEASE DO NOT OVER-TIGHTEN  
CAMBOLTS. PLEASE STOP WHEN  
YOU FEEL TIGHT**

**Step 1:**

Put all parts on a soft surface to prevent scratches.

Attach handle-A (O) to the top (A) using screws (M) and tighten with Phillips screwdriver as shown.

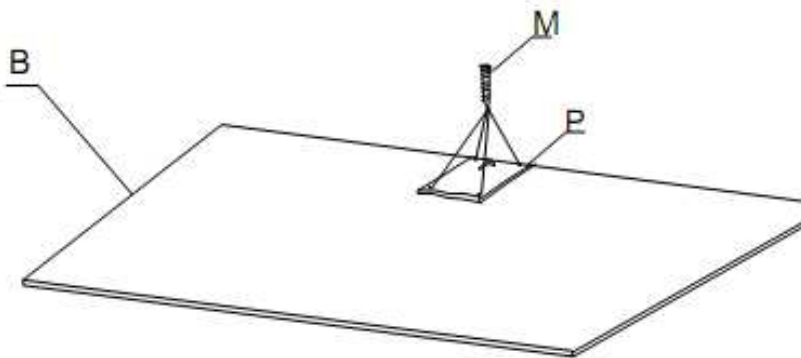

**Step 2:**

Attach handle-B (P) to front panel (B) using screws (M) and tighten with Phillips screwdriver as shown.

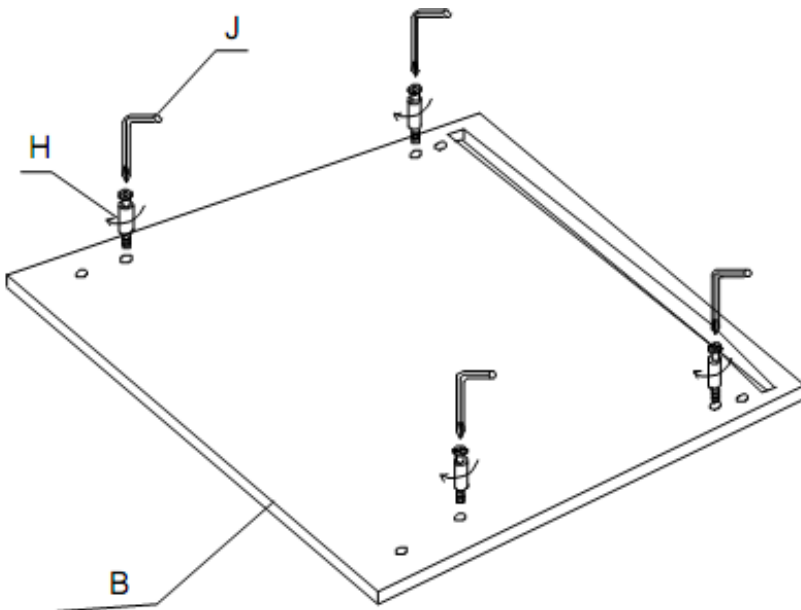

**Step 3:**

Screw small cam screws (H) into front panel (B) as shown.

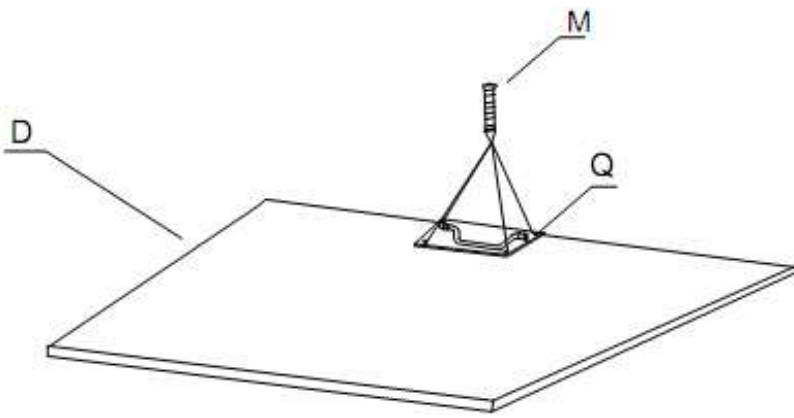

**Step 4:**  
 Attach handle (Q) to left side panel (D) and right side panel (G) using screws (M) and tighten with phillips screwdriver as shown.

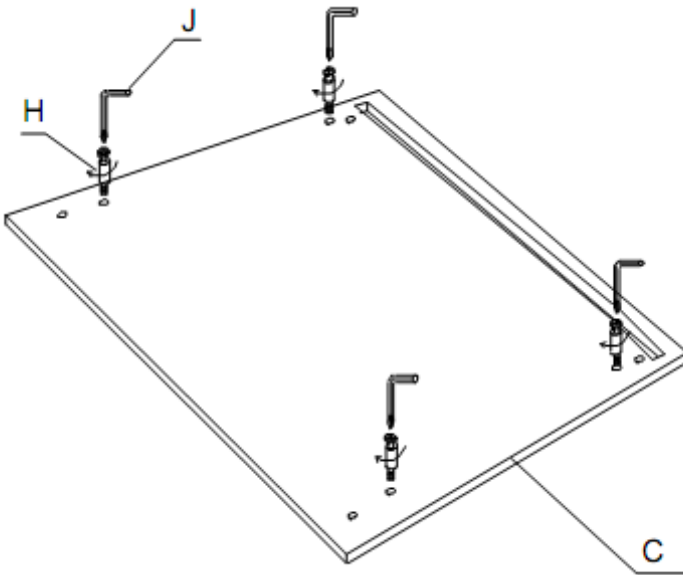

**Step 5:**  
 Screw small cam screws (H) into back panel (C) as shown.

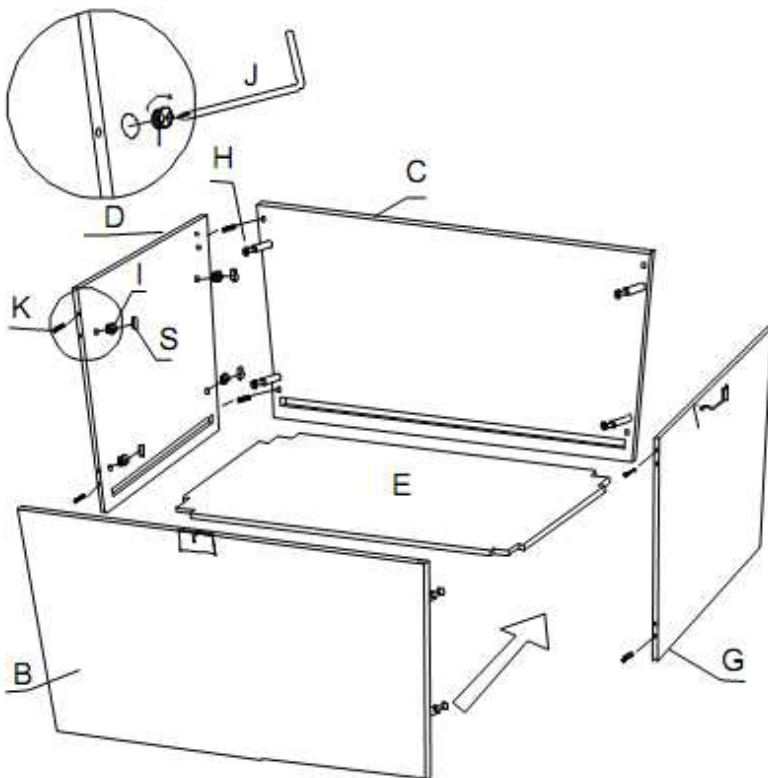

**Step 6:**  
 Insert dowels (K) into left side panel (D) and right side panel (G) as shown.

Assemble left side panel (D), right side panel (G), front panel (B), back panel (C) and bottom panel (E) together using small cam screws (H), small cam locks (I), dowels (K) and sponge cushions (S) as shown.

Make sure the edges of bottom panel (E) are inserted into the grooves of all panels.

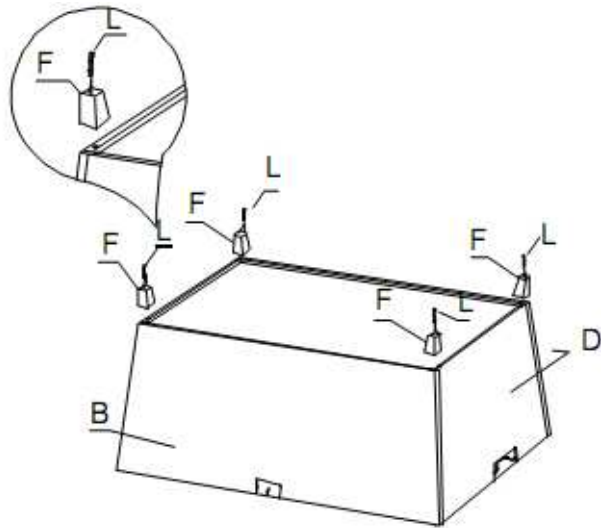

**Step 7:**  
 Turn the trunk base upside down and attach legs (F) to the bottom of trunk using screws (L) as shown.

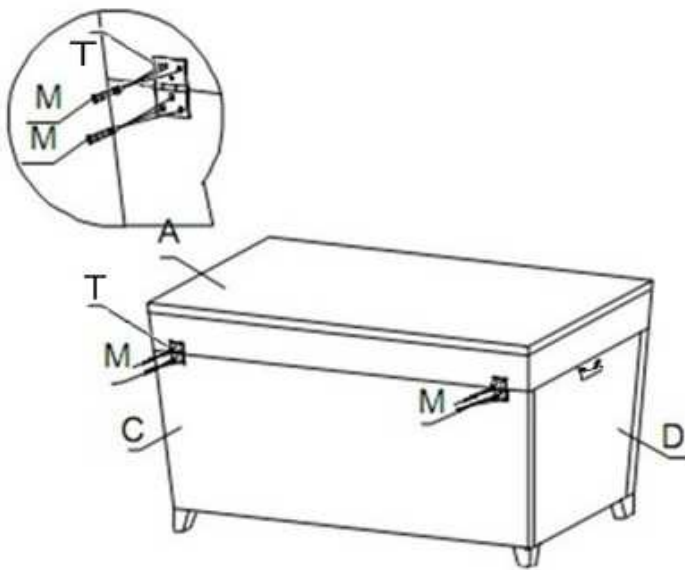

**Step 8:**  
 Attach Hinge (T) to back panel (C) and top panel (A) by using screws (M) as shown and then tighten all screw by phillips screwdriver(not included)

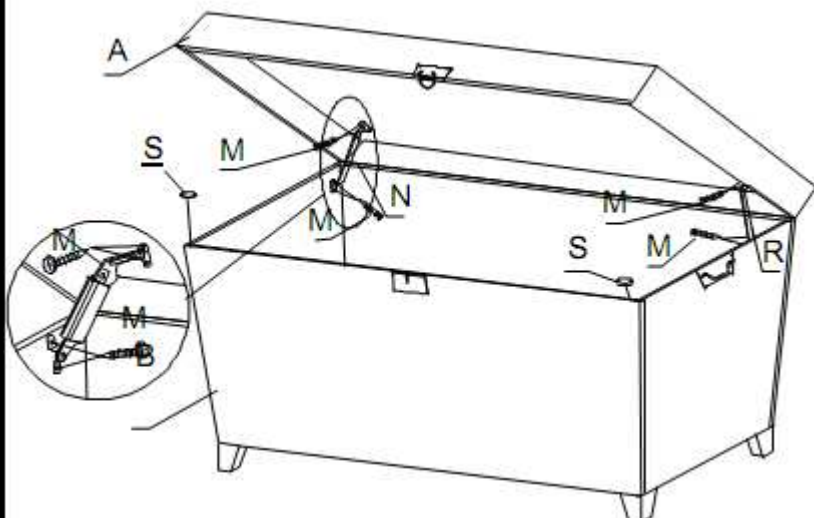

**Step 9:**  
 Attach left support (N) and right support (R) to the top (A) and trunk base using screws (M) and tighten with Phillips screwdriver as shown. Then put sponge cushions (S) on front panel (B) as shown. Close the top. Top will close slowly.

# Parts Replacement Form

## Customer Information

Name

---

Address

---

City/State/Zip Code

---

Phone Number

---

Please indicate where you purchased this item: Store/Website/Catalog

---

Please indicate color/size/style number:

---

Style No	Parts Letter	Parts Description	Quantity Needed
----------	--------------	-------------------	-----------------

---

---

---

Please immediately examine this product carefully. Any request for missing parts or damage replacement must be received within 90 days of your receipt of the product. Replacement, if available, will be honored within this time frame. Parts will not be available for items arriving fully assembled. We do not recommend modifying product(s) and we are not responsible for any damages due to product modification(s). If

damages or missing parts are not reported within 90 days of your receipt, we are under no obligation to provide parts or replacement merchandise.

Please contact Southern Enterprises at 800-633-5096 or in Dallas 972-869-0111/ 9am – 4pm Mon-Fri Central time if you have product issues or email us at [service@seidal.com](mailto:service@seidal.com). Please ask for customer service representative for issues involving damages or replacement parts. Please ask for technical assistance representative for any issues with product and assembly/construction.

Please contact the retailer that you purchased from for returns.



Customer Service 1-800-633-5096

[service@seidal.com](mailto:service@seidal.com)

Southern Enterprises, Inc.

600 Freeport Parkway, Suite 200

Coppell, Texas 75019