

CK622400TX- Espresso

CK612400TX- Black

# Nailhead Cocktail Table Trunk Assembly Instructions



**Southern**  
ENTERPRISES

For assistance with assembly contact:

Southern Enterprises Inc.

Customer Service 1-800-633-5096

[service@seidal.com](mailto:service@seidal.com)

[www.seidal.com](http://www.seidal.com)

PO#12972

Max Top Load 80 lbs.

Max Load Inside the Trunk 100 lbs.

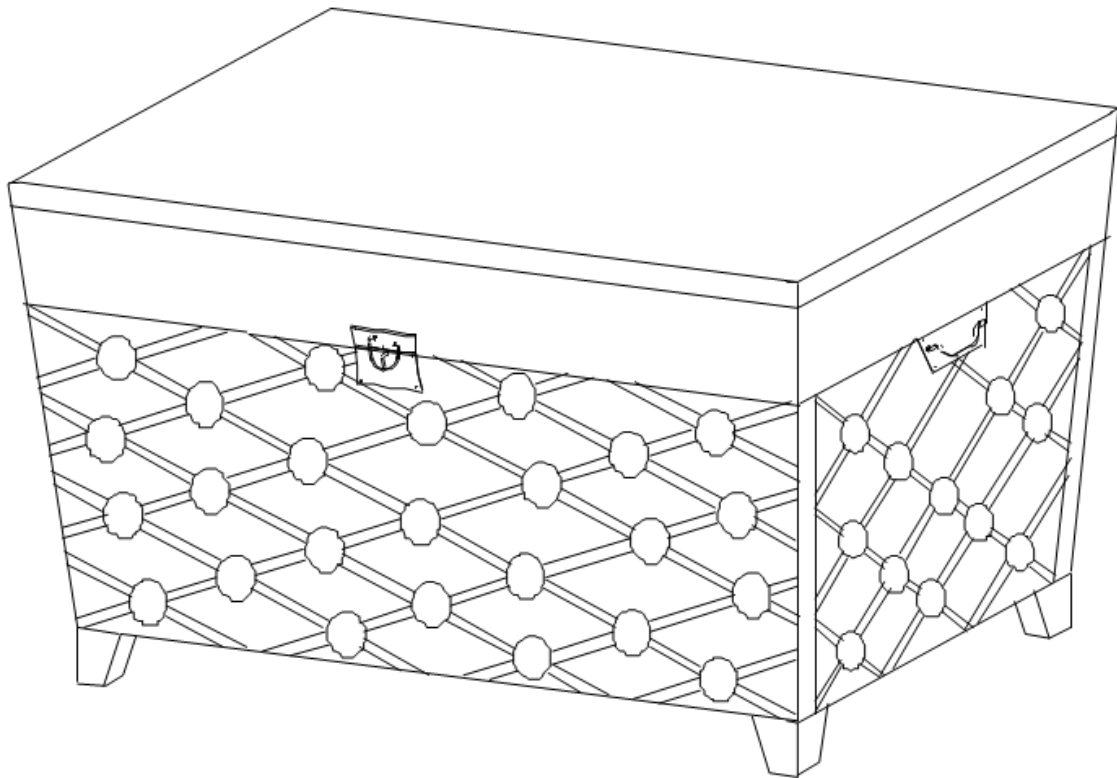

# CK622400TX- Espresso/ CK612400TX- Black

## Nailhead Cocktail Table Trunk

### Parts List

Please check packaging for all parts and hardware before discarding. Unpack and lay parts on clean, padded surface like carpet or blanket. Check that you have all parts indicated. Call customer service if hardware is missing. Before beginning assembly, carefully study the diagrams below and sort your hardware according to the pictures. Using the incorrect hardware will cause damage.

A 1 PC

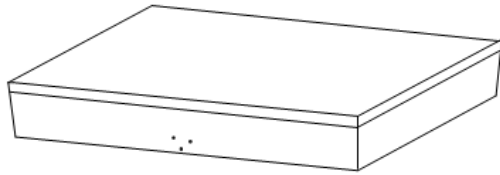

Top

B 1 PC

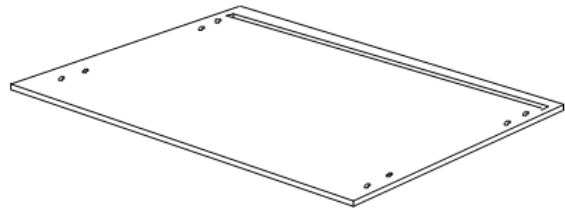

Front Panel

C 1 PC

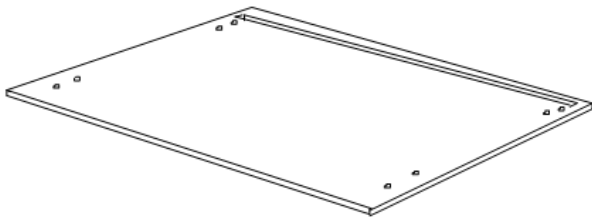

Back Panel

D 1 PC

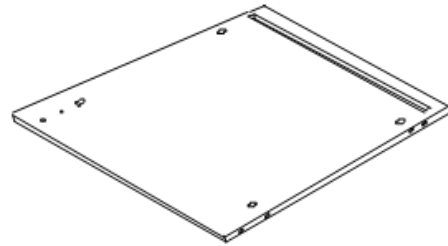

Left Side Panel

E 1 PC

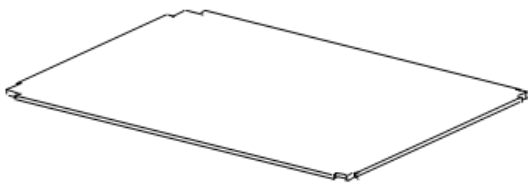

Bottom Panel

F 4 PCS

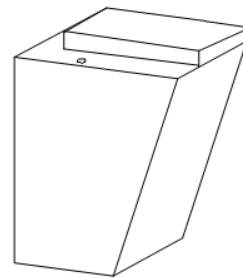





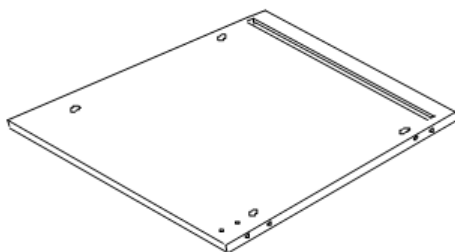

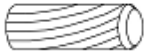

Leg

G 1 PC

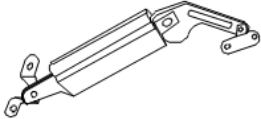
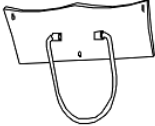

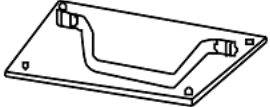
Right Side Panel

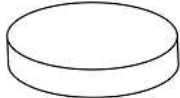
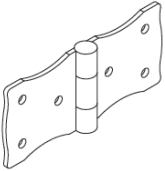
<p><b>H</b> 8 PCS</p>  <p>Cam Bolt φ6.8 x 36mm</p>	<p><b>I</b> 8 PCS</p>  <p>Cam Lock φ15 x 12mm</p>	<p><b>J</b> 1 PC</p>  <p>Wrench</p>
<p><b>K</b> 8 PCS</p>  <p>Dowel φ8 x 30mm</p>	<p><b>L</b> 8 PCS</p>  <p>Bolt φ 1/4" x 2 3/4"</p>	<p><b>M</b> 35 PCS</p>  <p>Screw φ 3.5 x 16mm</p>
<p><b>N</b> 1 PC</p>  <p>Left-Support</p>	<p><b>O</b> 1 PC</p>  <p>Handle-A</p>	<p><b>P</b> 1 PC</p>  <p>Handle-B</p>
<p><b>Q</b> 2 PCS</p>  <p>Handle</p>	<p><b>R</b> 1 PC</p>  <p>Right Support</p>	<p><b>S</b> 10 PCS</p>  <p>Sponge Cushion</p>
<p><b>T</b> 2 PCS</p>  <p>Hinge</p>		

**Care and Cleaning Instructions:**

Before using, wipe with a clean dry cloth. Periodically apply furniture wax to renew the finish. Avoid rubbing or scratching the surface with rough or abrasive objects.

For replacement parts or questions, please call customer service at 1-800-633-5096.

**Assembly Tool Required**  
**No.2 Phillips Screwdriver**

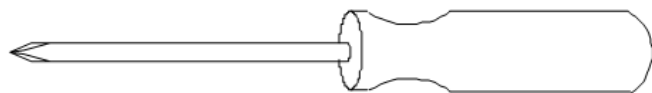

# CK622400TX- Espresso/ CK612400TX- Black

## Nailhead Cocktail Table Trunk Assembly Instructions

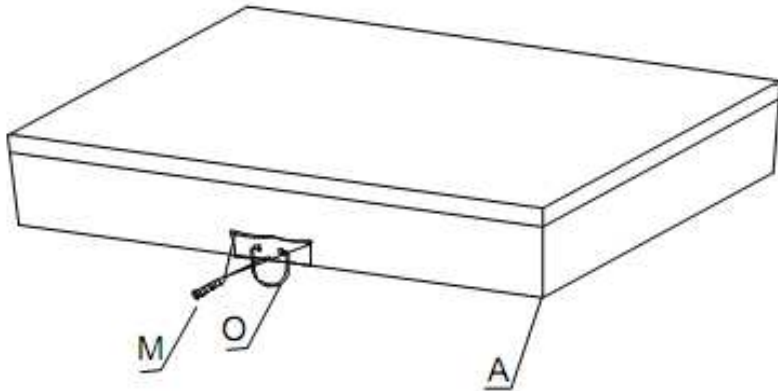

Please do not over-tighten cam bolts,  
please stop when you feel them tighten.

Attach handle (O) to the top (A) using screws  
(M) and tighten with Phillips screwdriver as  
shown.

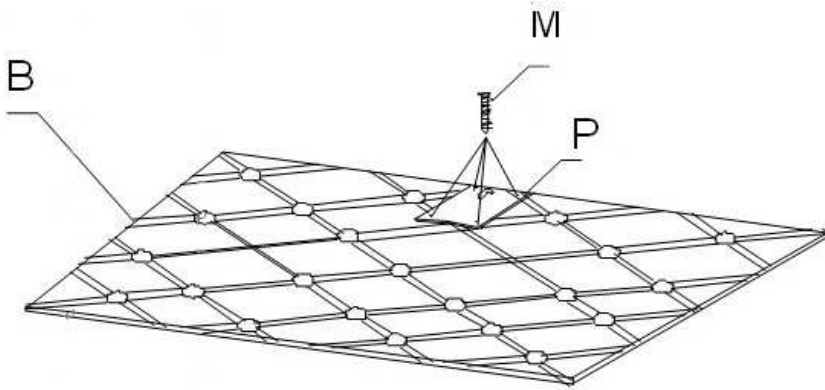

Attach handle (P) to front panel (B) using  
screws (M) and tighten with Phillips  
screwdriver as shown.

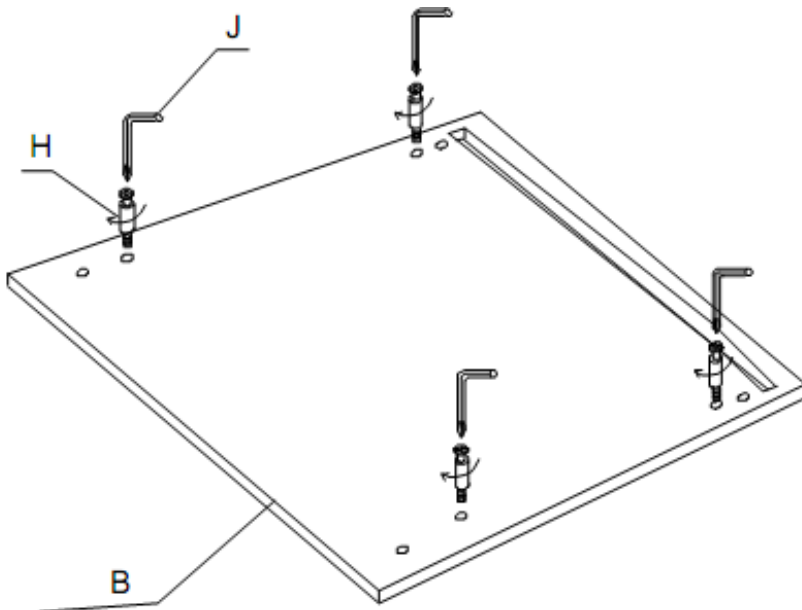

Screw small cam bolts (H) into front panel (B)  
as shown.

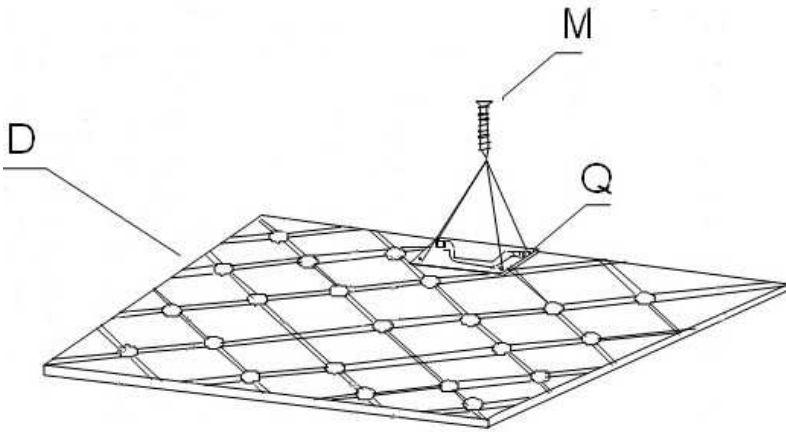

Attach handle (Q) to left side panel (D) and right side panel (G) using screws (M) and tighten with Phillips screwdriver as shown.

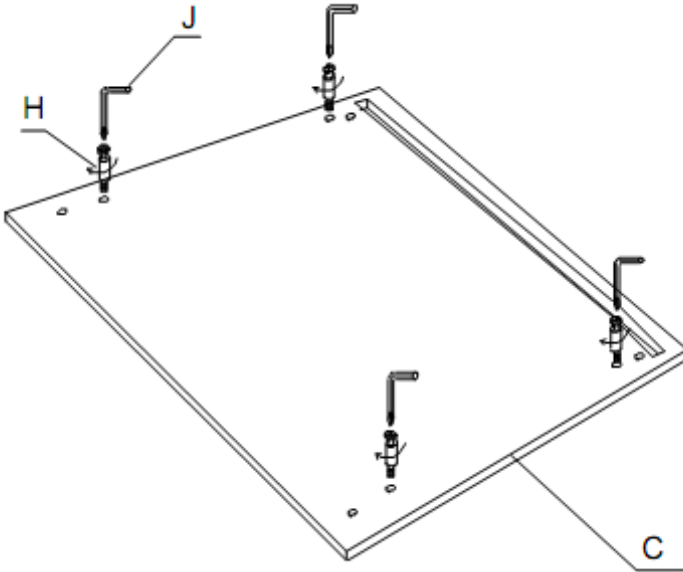

Screw small cam bolts (H) into back panel (C) as shown.

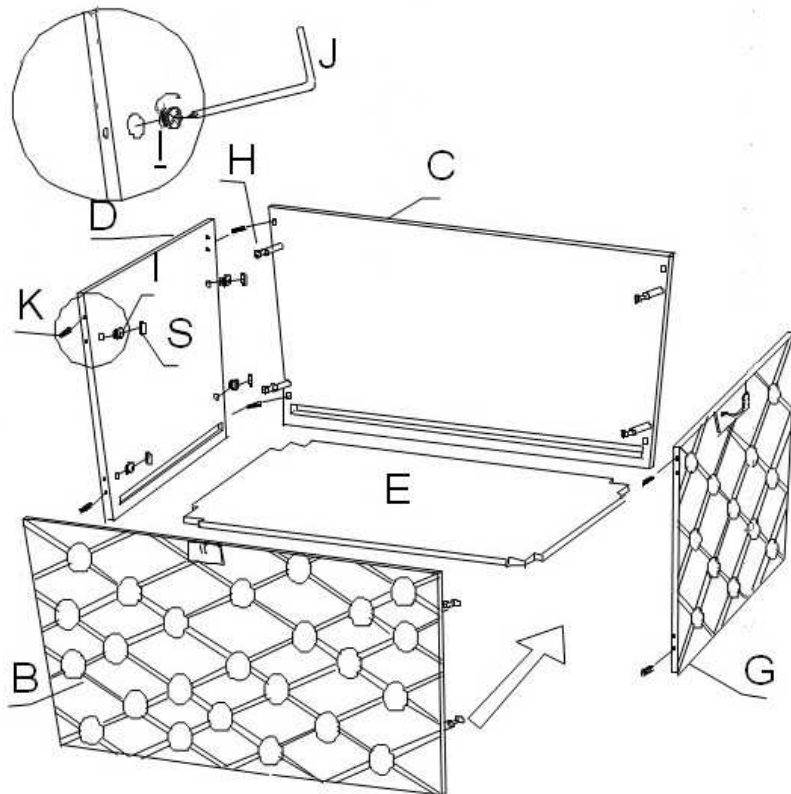

Insert dowels (K) into left side panel (D) and right side panel (G) as shown.

Assemble left side panel (D), right side panel (G), front panel (B), back panel (C) and bottom panel (E) together by inserting cam bolts (H) and dowels (K) into corresponding holes and joining panels together.

Insert cam locks (I) into corresponding holes and turn clockwise to tighten and secure panels.

Make sure the edges of bottom panel (E) are inserted into the grooves of panels.

Cover the cam locks with sponge cushions (S).

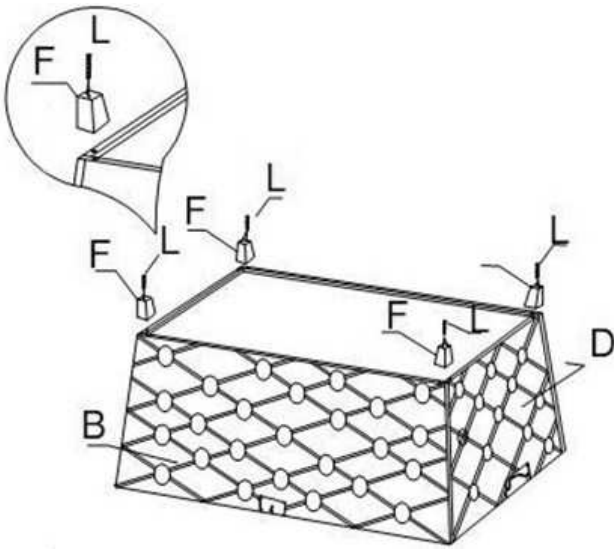

Turn the trunk base upside down and attach legs (F) to the bottom of trunk using screws (L) as shown.

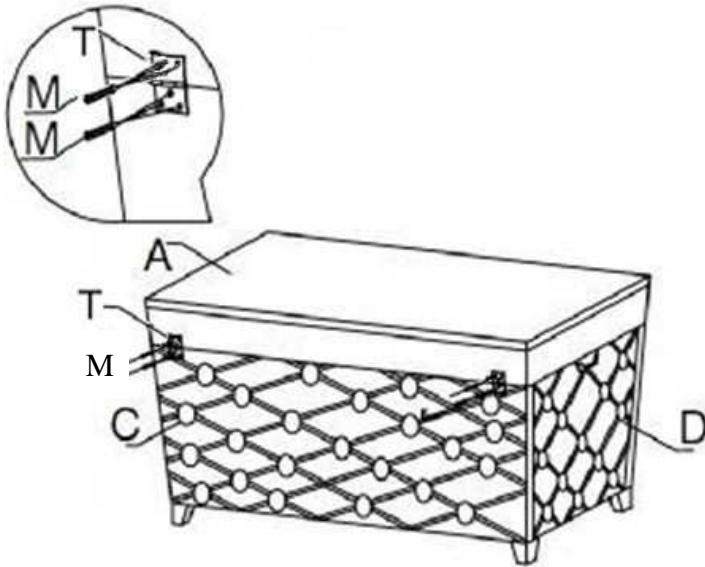

Attach hinge (T) to back panel (C) and top panel (A) by using screws (M) as shown and tighten all screw with Phillips screwdriver.

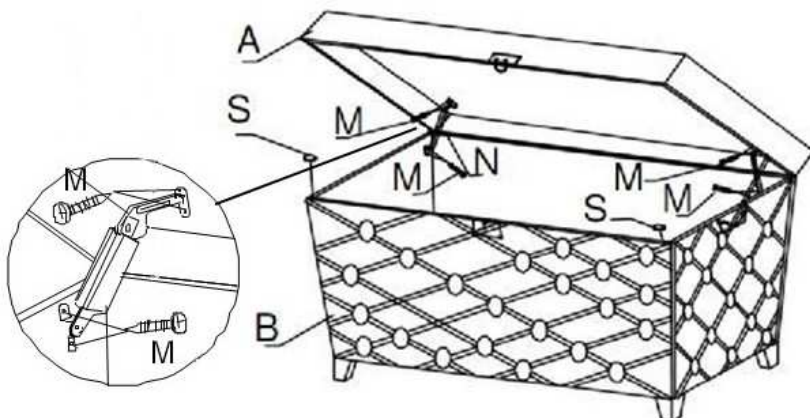

Attach left support (N) and right support (R) to the top (A) and trunk base using screws (M) and tighten with Phillips screwdriver as shown.

Place sponge cushions (S) on corners of front panel (B) as shown.

The top should close slowly.

# Parts Replacement Form

## Customer Information

Name \_\_\_\_\_

Address \_\_\_\_\_

City/State/Zip Code \_\_\_\_\_

Phone Number \_\_\_\_\_

Please indicate where you purchased this item: Store/Website/Catalog  
\_\_\_\_\_

Please indicate color/size/style number:  
\_\_\_\_\_

Style No	Parts Letter	Parts Description	Quantity Needed
_____	_____	_____	_____
_____	_____	_____	_____
_____	_____	_____	_____

Please immediately examine this product carefully. Any request for missing parts or damage replacement must be received within 90 days of your receipt of the product. Replacement, if available, will be honored within this time frame. Parts will not be available for items arriving fully assembled. We do not recommend modifying product(s) and we are not responsible for any damages due to product modification(s). If damages or missing parts are not reported within 90 days of your receipt, we are under no obligation to provide parts or replacement merchandise.

Please contact Southern Enterprises at 800-633-5096 or in Dallas 972-869-0111/ 9am – 4pm Mon-Fri Central time if you have product issues or email us at [service@seidal.com](mailto:service@seidal.com). Please ask for customer service representative for issues involving damages or replacement parts. Please ask for technical assistance representative for any issues with product and assembly/construction.

Please contact the retailer that you purchased from for returns.



**Southern**  
ENTERPRISES

Customer Service 1-800-633-5096

[service@seidal.com](mailto:service@seidal.com)

Southern Enterprises, Inc.

600 Freeport Parkway, Suite 200

Coppell, Texas 75019