



This guide contains procedures for common user serviceable repair tasks found on vinyl single and double-hung windows. If a condition arises that is not covered in this guide, please contact us for professional help. This product guide covers our current JELD-WEN Premium and Builders Series windows as well as our historical products with the following names: Seasonshield, Windowmaster, Wenco and Summit. For help identifying your window model, refer to your product purchase paperwork or call us for additional help.

Do-It-Yourself Technician

INTRODUCTION

Single and double-hung windows have two sashes, one upper and one lower. A single-hung window's lower sash operates and the upper sash is fixed. On a double-hung window, both sashes operate. An insect screen is mounted on the exterior side of the operating sash(es).

CONTACT US

- For questions, feel free to contact us by phone or email:
- Phone: 1-(800)-JELD-WEN/1-(800)-535-3936
 - Email: customerserviceagents@jeld-wen.com

TABLE OF CONTENTS

Precautions and Safety	2
Needed Materials & Tools	2
Sash Removal & Installation	2
Balance Replacement & Adjustment.....	3
Lock Replacement & Adjustment	7
Proper Window Installation	8
Troubleshooting Operational Problems	9
Glossary.....	11

SINGLE AND DOUBLE-HUNG WINDOW ANATOMY

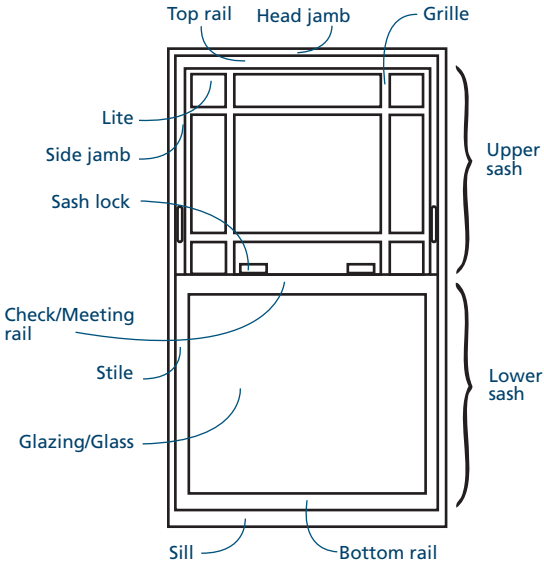

The repair tasks offered herein can be accomplished by a homeowner with some mechanical aptitude. If you are unsure, it is recommended that you hire a trained service provider such as a competent and licensed construction contractor or building professional. JELD-WEN disclaims any and all liability associated with the use and/or provision of these instructions. Any reliance upon the information or advice is at the risk of the party so relying. The information contained herein may be changed from time to time without notification.



PRECAUTIONS AND SAFETY

- Follow all manufacturers' instructions and labels.
- Use proper and safe equipment and precautions if servicing the exterior side of windows above ground level.
- Window insect screens are not security devices and will not prevent children, other people, or pets from falling through.
- Use extra care when driving screws near glass unit to avoid breakage.

- Use caution when tightening screws to avoid stripping the screw holes.
- Sash removal can be awkward and could cause physical injury or product damage; we recommend the help of a second person.
- Maintain a strong grip on balance when removing or installing. Balances are spring-loaded and they will decompress quickly if released, possibly causing personal injury and/or product damage.
- Beware of oil causing slippery surfaces.

NEEDED TOOLS AND MATERIALS

NEEDED TOOLS

Note! Each tool is not required for every task.

- Tape measure
- Level
- Putty knife
- Flat head screwdriver
- Phillips head screwdriver
- Spiral adjustment tool (ask your supplier for one) or locking needle-nose pliers
- Utility knife
- Mini hacksaw
- Needle nose pliers
- Pencil or scribe
- File

NEEDED MATERIALS

- Replacement parts
- String
- Tape
- Scrap wood

SASH REMOVAL AND INSTALLATION

A **tilt sash** has thumb latches (sash retainer latches) on the top two corners of the sash and can vary in shape and size.

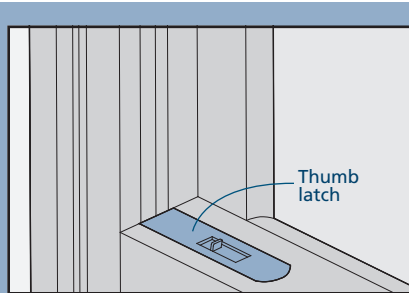

A **side load sash** does not tilt, is removed from the side, and has metal take-out clips in the side jamb just above the lower sash.

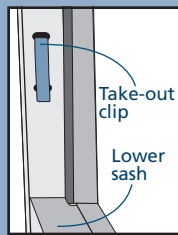

3. Pull sash toward the interior and hold horizontally while tilting out to keep the balance shoe from releasing and popping up. Take note of which jamb channel the sash is in (the sash will need to be reinstalled in the same channel).
4. Tilt sash toward interior at a 90° angle.
5. Lift one side of sash to release pivot pin from balance shoe in the side jamb. Notice the position of the balance shoe in the side jamb for replacement.
6. Slightly swing sash to remove.

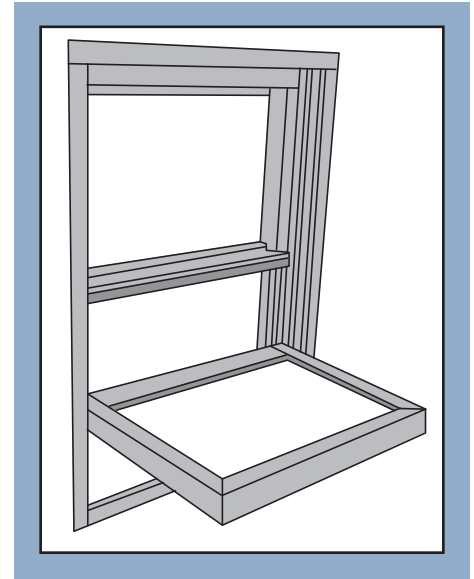

TILT SASH REMOVAL & INSTALLATION

Note: Double-hung windows require the lower sash be removed before the upper sash and the upper sash installed before the lower sash. Label top and bottom sash for reinstallation. The lock is on the bottom sash.

REMOVAL

1. Open sash at least half way.
2. Press sash thumb latches toward center of window.

INSTALLATION

1. Insert one pivot pin on one corner of the sash into the balance shoe in the side jamb or slide the pivot pin into the balance shoe from the top depending on configuration of pin/shoe combination.
2. Carefully slide engaged pivot pin and balance shoe downward or upward until pivot pin on the opposite side can be aligned and inserted into balance shoe. Sash should be horizontal at this point.
3. Tilt the sash up into place and engage both thumb latches.
4. Test the sash operation. If the sash does not move freely in the window frame, the pivot pins may not be engaged properly. Remove and reinstall taking care to engage the pivot pins on both sides.

-Continued

SASH REMOVAL AND INSTALLATION - CONTINUED

SIDE LOAD SASH REMOVAL AND INSTALLATION

REMOVAL

1. Locate metal take-out clips in side jambs, just above the lower sash, on both sides of window.
2. Lift bottom of take-out clips with a flat head screwdriver until they snap into angled position. Leave take-out clips in angled position until sash is reinstalled.

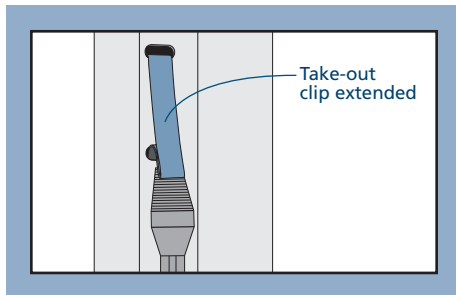

3. Slide top of sash several inches above take-out clips.
4. Push sash toward one side jamb until it is clear of the opposite side jamb and remove.

INSTALLATION

1. Insert one side of sash into one side jamb above metal take-out clips.
2. Fit other side of sash into opposite side jamb.
3. Close sash.
4. Level take-out clips flush to side jambs.
5. Test sash operation. If sash does not move freely or lock does not engage, remove and reinstall.

BALANCE REPLACEMENT AND ADJUSTMENT

A balance system controls the movement of a sash in a single or double-hung window. If you need help to determine if you need a new balance, call our service department. Order the same balance type you have and specify your sash size. Balances are designed to support different sash sizes. A large sash requires a different balance than a smaller sash. A properly fitting balance will be the correct length, hold the sash weight, and fit with all other components. If a balance needs to be replaced, we recommend replacing all balances in the window at the same time. Read and understand all instructions before beginning.

IDENTIFY BALANCE TYPE

Remove the sash(es) to identify balances. There are three types of balance systems: block and tackle (Type A, B and C), spiral and constant force.

- The Type A balance does not have a balance shoe and is encased in a metal sleeve.
- The Type B balance has a balance shoe, and the spring, pulleys, and lines are exposed.
- The Type C balance has a balance shoe and is encased in a metal sleeve. Some balance shoes are locking and some are non-locking.
- The spiral balance is encased in a metal sleeve and has locking shoes.
- The constant force balance is a metal coiled spring inside a plastic case.

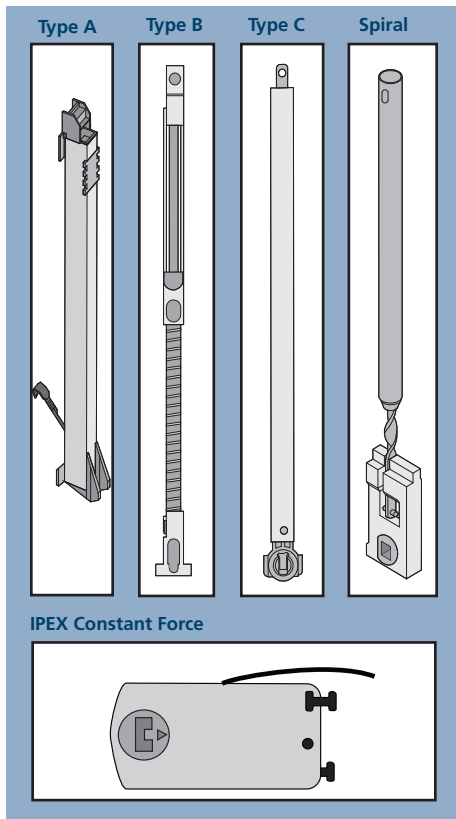

BLOCK & TACKLE TYPE A BALANCE

Type A balances are used on single-hung windows with a side load sash and metal take-out clips in the side jambs. Some Type A balances may have slight differences.

REMOVAL

1. Tightly grip both ends of balance. Pull down to release balance top from metal takeout clip.
2. Firmly hold both ends of balance (do not grip underside of balance or injury may result), and allow balance to lift up to release tension.
3. Remove cord hook on bottom back side of balance from mounting hole in side jamb, and remove balance.

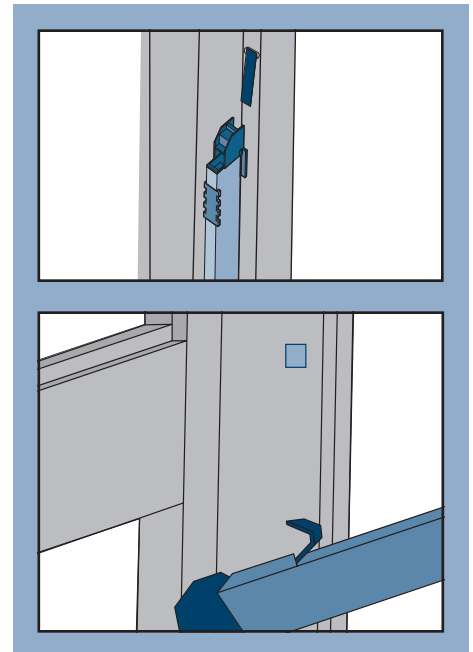

INSTALLATION

1. Insert cord hook in side jamb mounting hole.
2. Tightly grip both ends of balance, press down and hook top under metal takeout clip.
3. Reinstall sash.
4. Test sash operation and make sure lock fully engages. If the sash does not move freely or the lock does not engage, remove and reinstall the sash and/or balances.

-Continued

BALANCE REPLACEMENT AND ADJUSTMENT - CONTINUED

BLOCK & TACKLE TYPE B & C BALANCE WITH LOCKING SHOE

Types B and C are used on single and double-hung windows with thumb latches on both sides of the sash top.

REMOVAL

1. Remove sash. The balances are now exposed in side jambs.
2. Locate screw (or hook) at top. The balance is under tension, so remove carefully. Hold the end with pliers and either remove the screw or unhook the hook. Slowly allow the tension to release.
3. Type C balances, on the bottom, have a locking balance shoe. Turn the locking balance shoe 90° to a horizontal position with a flat head screwdriver to unlock it.
4. Take note of each balance's position in each side jamb and then tilt out from top.
5. Twist until the balance shoe clears track and remove.

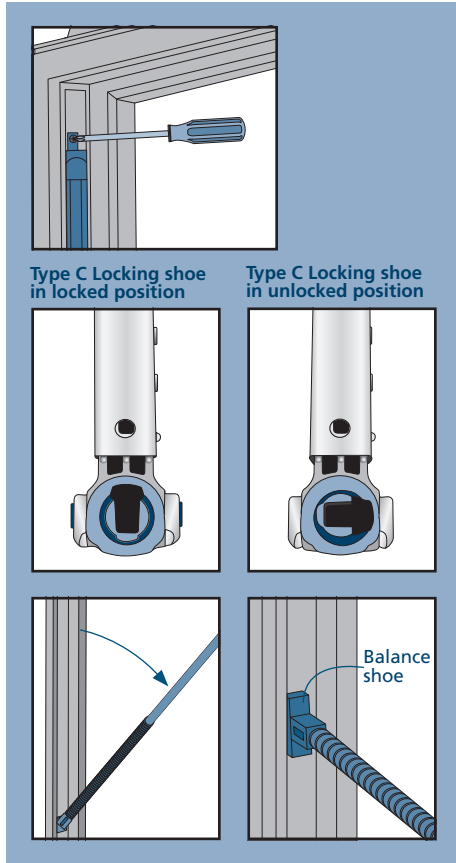

INSTALLATION

1. With balance horizontal, insert balance shoe into track in side jamb in the same position they were removed from. Twist to lock in place.
2. Tilt top end of the balance up into track.
3. On the bottom of type C balances, turn the locking balance shoe 90° to a vertical position with a flat head screwdriver to lock it.
4. Align metal screw tab at top of balance to screw hole in side jamb; insert and tighten screw, or, re-attach hook into hole.
5. Reinstall sash.
6. If the sash does not move freely in the window frame, the balance system may not be installed correctly or the pivot pins on the sash may not be properly engaged. Remove and reinstall the sash and/or balances again and take care to engage the pivot pins on both sides.

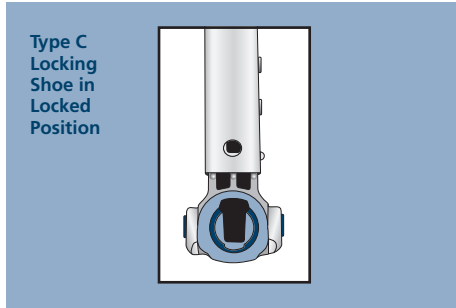

SPIRAL BALANCE

A spiral balance system is made up of a tensioned spiral-shaped rod extending from a steel tube down into a balance shoe that grips the rod and holds the tension. Replace with caution. Tension must be set for proper operation on a new balance.

An existing balance may only need adjustment (not replacement) for proper operation. Adjust tension equally on each balance. Adjustment tools and balances may vary in shape and size.

REMOVAL

1. Remove sash.
 2. Remove sash stop (if present) by pulling on one end until it comes out.
 3. Lift and pull off balance cover (if present) to expose balance.
 4. Grip bottom end of spiral rod with adjustment tool. Pull down then lift out of balance shoe (balance shoe remains in channel).
- Note!** If you do not have a spiral balance adjustment tool, use locking needle nose pliers, but with extreme caution.
5. Tightly hold adjustment tool and allow spiral rod to move up and unwind.
 6. At the top, unscrew and remove balance.

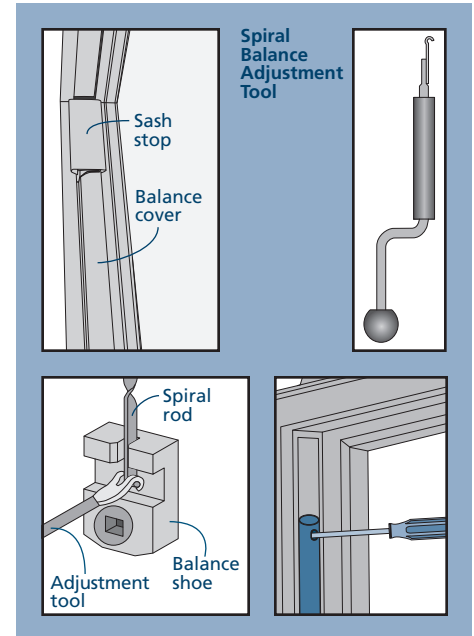

INSTALLATION

1. Screw top of new balance into place in side jamb.
2. Grip bottom end of spiral rod with adjustment tool. Pull down and rotate clockwise two turns to set tension. Maintain grip on tool for next step.
3. Pull spiral rod down and fully engage into balance shoe.
4. Replace balance cover (if present).
5. Replace sash stop (if present).
6. Reinstall sash and test operation.

ADJUSTMENT

1. Remove sash and disconnect spiral rod from balance shoe with adjustment tool as described above in "spiral balance removal."
2. Adjust as follows, but do not exceed more than two full turns at a time:
 - If sash drops, rotate clockwise to add tension. Add tension to both sides equally.
 - If sash pops up, rotate counter-clockwise to decrease tension.
3. Reconnect spiral rod to balance shoe.
4. Reinstall sash and test operation. If necessary, repeat process until sash operates smoothly.

BALANCE REPLACEMENT AND ADJUSTMENT - CONTINUED

IPEX CONSTANT FORCE BALANCE REMOVAL AND INSTALLATION

Depending on the weight of the sash, single balances may be used or if the sash is heavier, additional balances are attached as needed. Remove the stops (pry out with a flat screwdriver) to see the balance configuration and note location and number of balances. Have this information ready before ordering new balances.

BALANCE REMOVAL

Lower Sash Balance – Access opening at top of jamb

1. Remove both sashes. Double hung windows require the lower sash be removed before the upper sash.
2. Remove the stop in the interior channel at the head by prying it up from the bottom and out.
3. To unlock balance, insert a 1/4" flat screwdriver in the pivot bar opening of the balance, hold firmly to prevent the balance from flying upward, and rotate 90°. Slowly allow the balance to fully retract.
4. Remove the screw(s) from the mounting bracket, and, using needle nose pliers, disengage the mounting bracket from the balance spring(s), and remove.
5. Slide the balance to the access opening, and remove from the jamb. For help pulling the old balance cases out, drive a #8 x 3" drywall or deck screw into the friction adjustment screw hole and pull out from the top.
6. Multi-spring balances are connected by means of the "dog bones" at the top of each balance section. Pull each additional unit up to clear the access opening and then straight out, sliding the dog bone connectors apart.

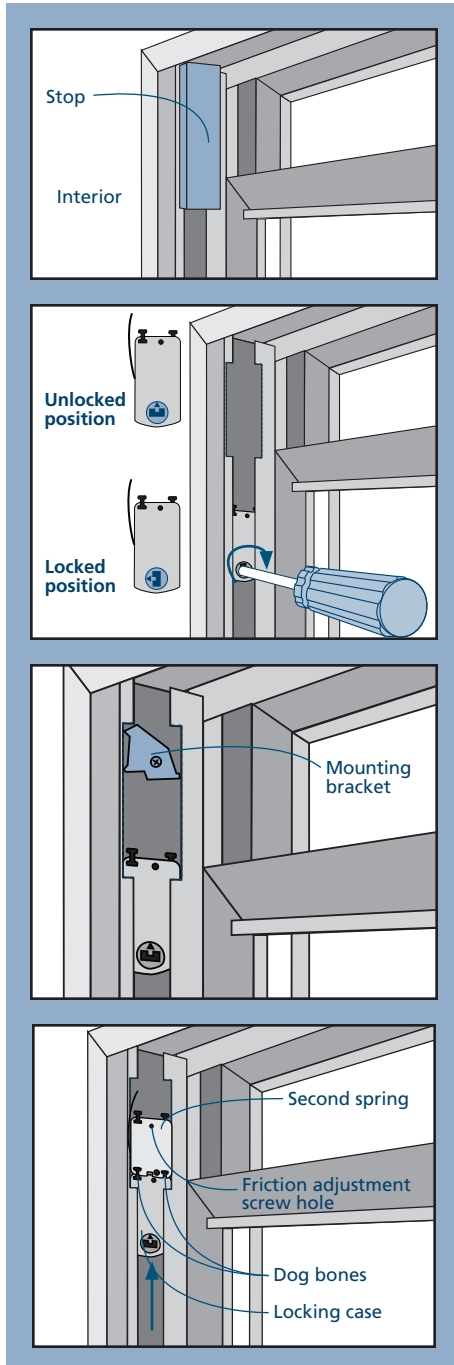

BALANCE REMOVAL - CONTINUED

Upper Sash Balance – Access opening at bottom of jamb

1. Remove both sashes. Double hung windows require the lower sash be removed before the upper sash.
2. Remove the stop in the exterior channel at the sill by prying it up from the top and out.
3. To unlock balance, insert a 1/4" flat screwdriver in the pivot bar opening of the balance, hold firmly to prevent the balance from flying upward, and rotate 90°. Slowly allow the balance to fully retract.
4. Remove the screw(s) from the mounting bracket, and, using needle nose pliers, disengage the mounting bracket from the balance spring(s), and remove.
5. Slide the balance to the access opening, and remove from the jamb. For help pulling the old balance cases out, drive a #8 X 3" drywall or deck screw into the friction adjustment screw hole and pull out from the top.
6. Multi-spring balances are connected by means of the "dog bones" at the top of each balance section. Pull each additional unit up to clear the access opening and then straight out, sliding the dog bone connectors apart.

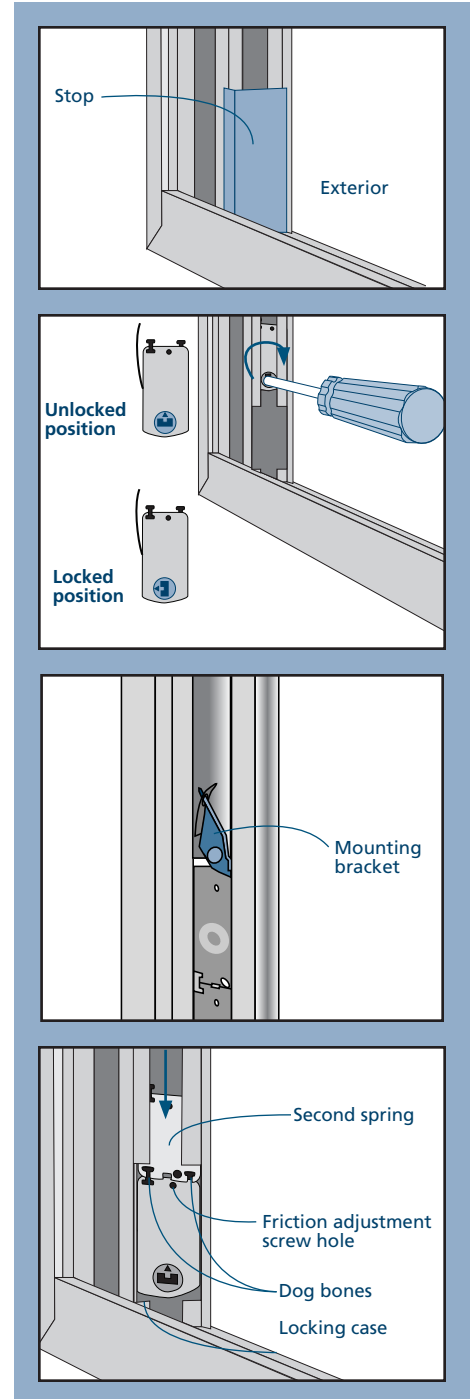

BALANCE REPLACEMENT AND ADJUSTMENT - CONTINUED

BALANCE INSTALLATION

Lower Sash Balance – Access opening at top of jamb

1. Install the locking case first with the spring exiting the case toward the interior of the window, the locking collar in the unlocked position and any excess spring tail length wrapped over the dog bone end of the locking case assembly.

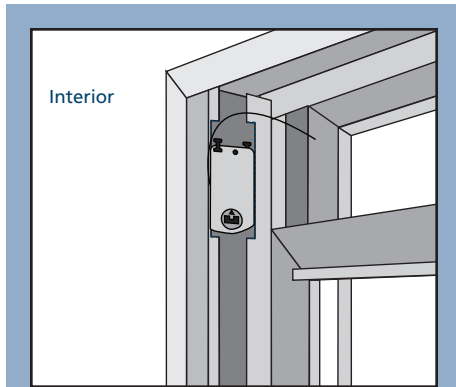

2. Insert the bottom end of the locking case assembly into the access opening and pull downward until the balance case and spring tail fully enter the jamb pocket.

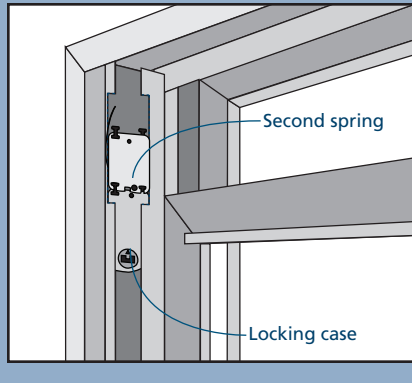

3. For multi-spring balances, slide the locking case upward until the dog bones are just above the lower edge of the access opening. Place the tail of the second spring in the pocket, adjacent to the first spring tail and align the dog bones of the locking case with the dog bone slots of the second spring case. Slide the second spring case into the access opening. For triple spring balances, connect the third spring case by the same method as the second.
4. Align the mounting holes of all springs, using needle nose pliers.

5. Grasp the mounting bracket with a needle nose plier (inset), insert the upper hook of the mounting bracket through the upper holes of all springs (make sure to engage all springs).

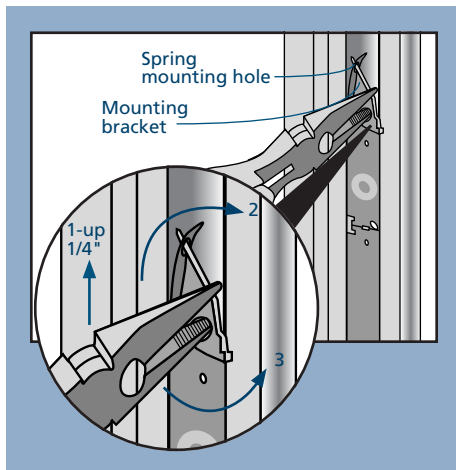

6. While holding back the balance assembly, pull the springs upward approximately 1/4" (1) with the bracket, and rotate the bracket about a horizontal axis, to insert the second hook through the lower holes of all springs (2 - behind the pliers in the image).
7. Rotate the bracket about a vertical axis, to insert the back tab beneath the edge of a dog bone (3).
8. Slide the complete balance assembly and mounting bracket to the original mounting position, and secure with the original screw.

Upper Sash Balance – Access opening at the sill

1. For multi-spring balances, install the uppermost spring case (short tail spring), and slide upward until the dog bone slots are just below the top of the access opening.
2. For additional balances, insert the bottom of the second case into the opening, and partially engage the dog bones into the first case. Grasp the spring tail with a needle nose plier, between the two holes, and push the spring tail down, until the end can be inserted through the access opening, alongside the first case.

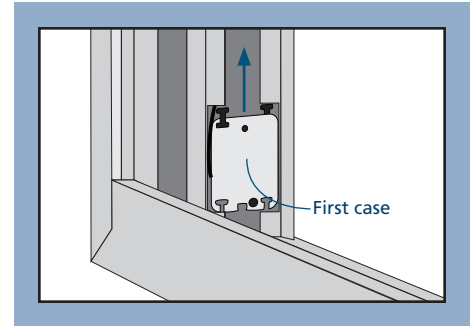

3. Push the spring tail and the balance case fully into the jamb pocket.
4. Slide the assembly up the jamb pocket, and back down, to facilitate feeding the second spring tail past the first spring case.
5. Install the locking case assembly in the same manner if the locking case assembly contains a medium or long tailed spring.
6. Align the mounting holes of all springs, using needle nose pliers.
7. Grasp the mounting bracket with a needle nose plier (inset), insert the upper hook of the mounting bracket through the upper holes of all springs (make sure to engage all springs).

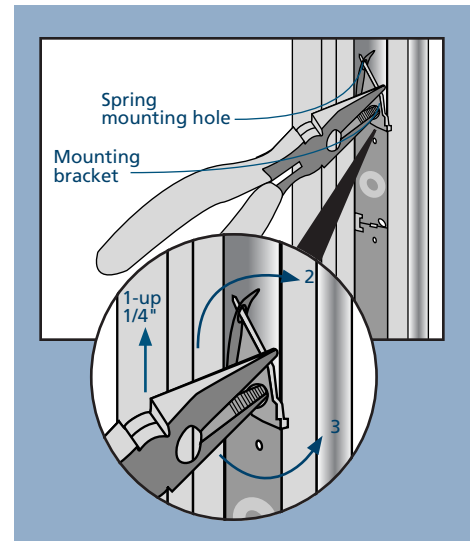

8. While holding back the balance assembly, pull the springs upward approximately 1/4" (1) with the bracket, and rotate the bracket about a horizontal axis, to insert the second hook through the lower holes of all springs (2 - behind the pliers in the image).
9. Rotate the bracket about a vertical axis, to insert the back tab beneath the edge of a dog bone (3).
10. Slide the complete balance assembly and mounting bracket to the original mounting position, and secure with the original screw.

BALANCE REPLACEMENT AND ADJUSTMENT - CONTINUED

SASH INSTALLATION

1. Insert a 1/4" flat blade screwdriver into the pivot bar opening of the locking collar and pull the balance assembly to a position several inches above or below the position of the opposite sash balance. Rotate the locking collar to lock the balance for sash installation.
2. Make sure that the arrow head on the face of the locking collar is pointed toward the interior side of the window.
3. If upper sash was removed, install it first.
4. Hold sash approximately horizontal, with interior glass surface facing downward and pivot bars toward the window frame.

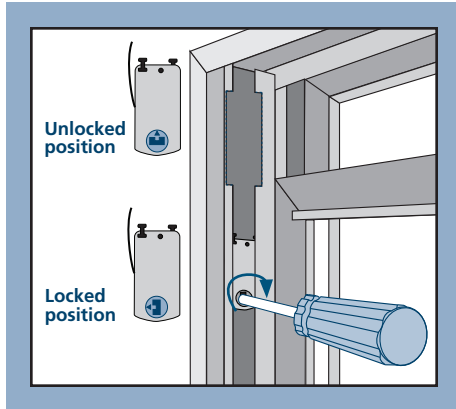

5. Tilt the sash slightly to one side, and insert one pivot bar into the pivot bar opening of the appropriate balance. Force this balance upward or downward, until the opposite pivot bar can be aligned with and inserted into the pivot bar opening of the opposite balance.
6. Continue forcing the first balance upward or downward, until it is approximately opposite the second, then tilt the sash closed, and latch.

STOP INSTALLATION

1. Cut stop to length (access opening length + 1/2") if necessary.
2. Snap stop into opening between return legs, over access opening.

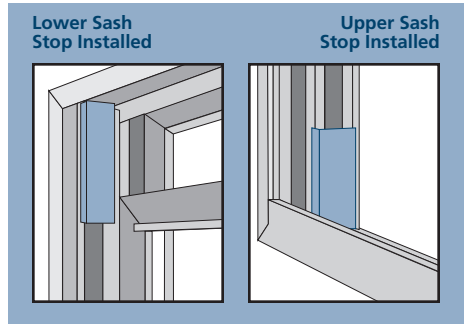

LOCK REPLACEMENT AND ADJUSTMENT

Different lock styles were used during different periods of manufacture. Each window will have either a cam lock, WEN-Lock™, or MAG-Lock®. Replace the lock if it is broken; adjust the keeper if applicable. A cam lock and a WEN-Lock with a smooth top do not have adjustable keepers. A WEN-Lock with visible screws on the top has an adjustable keeper.

Note! Operating sashes must be unlocked and open, or removed, before attempting lock removal. There is a metal stiffener in each sash. To avoid disturbing the location of the stiffener, if the sash(es) are removed, the lock rail must be kept horizontal before and during lock removal and installation.

CAM LOCK REPLACEMENT

1. Unscrew and remove old lock and keeper.
2. Install new lock and keeper in the same place.

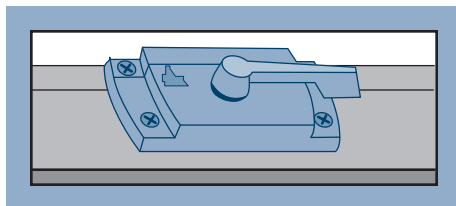

WEN-LOCK REPLACEMENT

1. If screws are not visible, grip top of lock and snap it off to expose the screws holding the lock on the unit.
2. Unscrew and remove.
3. Install new lock in the same place.

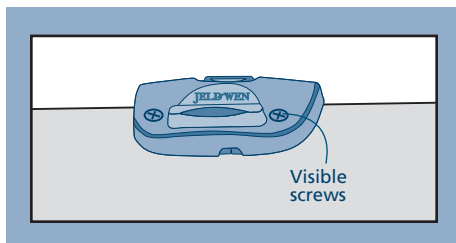

MAG-LOCK REPLACEMENT

1. Pull up on the handle and glide a putty knife into the gap between the sash and lock on one side. The putty knife will depress a projecting tab on the lock and allow it to be slid out.
2. Repeat for the other side and remove lock.
3. Install new lock by snapping it into the sash in the same position as the old lock. Install the new keeper and adjust as necessary.

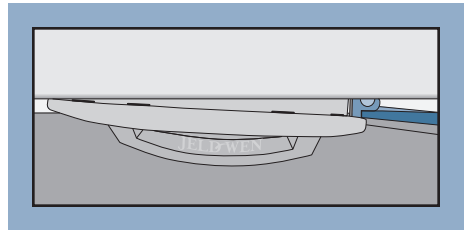

WEN-LOCK AND MAG-LOCK KEEPER ADJUSTMENT

1. Remove sash for unobstructed access to keeper.
2. Loosen both screws in keeper (do not remove).
3. For the WEN-Lock, raise keeper and insert shim.
4. For the MAG-Lock, the keeper may be moved right or left.
5. Retighten screws, close and lock window and test new alignment.

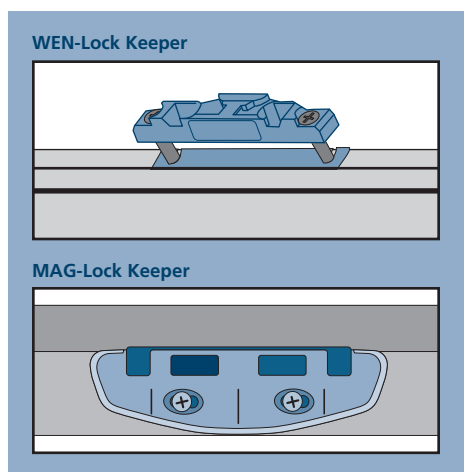

PROPER WINDOW INSTALLATION

- Proper installation is essential for keeping windows operating smoothly. If a window fails to operate properly, an inspection is necessary to determine if it was installed correctly.
- These inspection instructions apply to flat window types. Bow windows, bay windows, and unusual geometric-shaped windows are more complicated and should be inspected by a window professional.
- A contractor or installer can assist in determining the cause of a window being “out of specification” and possibly correct it. Window problems due to improper installation are usually not covered by the manufacturer’s warranty. For installation instructions, contact us or your supplier.
- The specifications and measurements referenced in this guide are taken from ASTM E2112 Standard Practice for Installation of Exterior Windows, Doors and Skylights.

Note: These instructions do not address inspection for proper “water tightness” or flashing. A “water tight” inspection requires removal of the exterior siding around the window. Seek professional assistance regarding this issue.

LEVEL INDICATOR

Accurate measurements are essential in determining level and plumb. Most carpenters’ levels have several bubble level indicators, making it possible to measure all parts of the window.

Examine the horizontal indicator. If the bubble is centered between the lines of the indicator, it is level.

If the bubble is not exactly centered, measure how far “out of level” or “out of plumb” by maneuvering the end of the level until the bubble is exactly centered. Measure the farthest gap between the level and the surface. On a 2’ level, the gap must not exceed 1/16”, or on a 4’ level (or longer), the gap must not exceed 1/8”, or the surface is out of level/plumb.

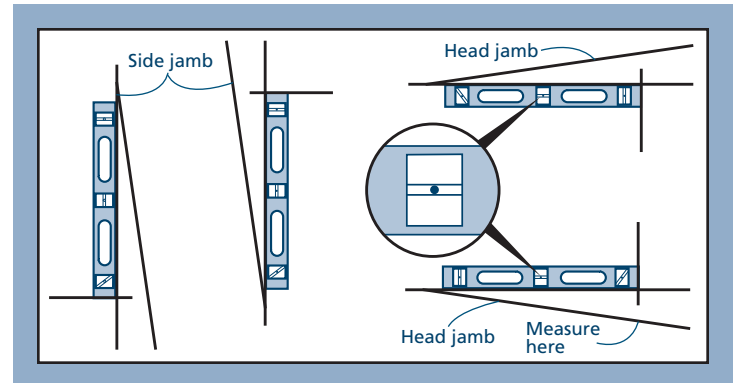

SQUARE

Measure frame/sash from top left to bottom right corner and from top right to bottom left corner. If measurements differ by 1/8" for windows up to 20 sq. ft. or 1/4" for windows larger than 20 sq.ft., unit is out-of-square.

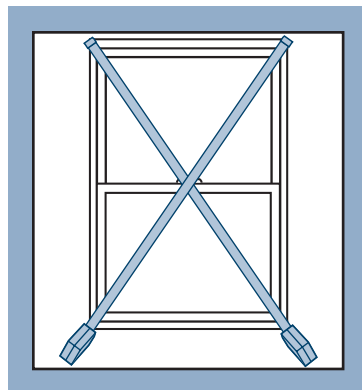

FRAME TWISTS

Attach two pieces of string to frame/sash, corner to corner. If there is a gap between strings at center point larger than 1/8" for windows up to 4' wide or high, or 3/16" for windows larger than 4' wide or high, the frame is not flat. Repeat by switching strings and re-measuring.

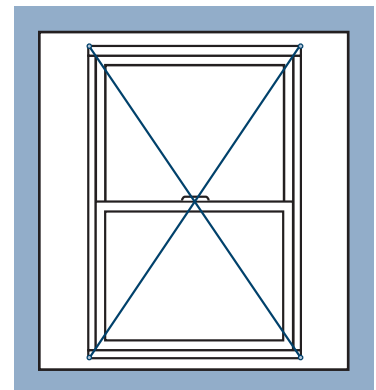

LEVEL AND PLUMB

For plumb, place level against each side jamb or use a plumb bob. For level, place level against head jamb and sill.

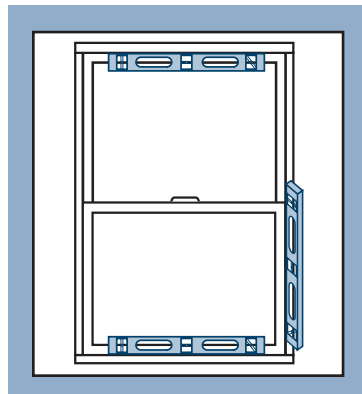

PROPER SHIMMING

Measure width of frame at top, center, and bottom. If any two measurements differ more than 1/16", the frame is over or under shimmed. Repeat process and measure height of frame.

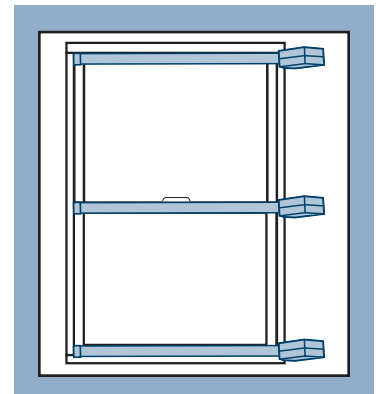

PROPER WINDOW INSTALLATION - CONTINUED

STRAIGHT SIDE JAMBS

Place level against inside of side jamb. Look for gaps anywhere between level and side jamb. Repeat steps for other side jamb. Some Double-Hungs with balances have adjustment screws located about half way up the balance. Turn screws in 1/4 turn increments until gap is less than 1/16".

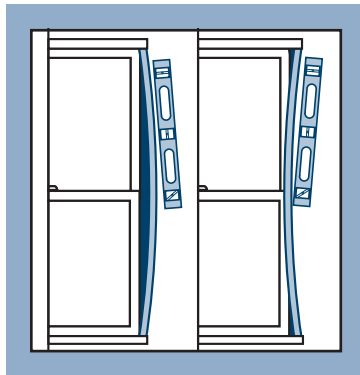

FRAME/PANEL BOW

Inspect interior and exterior frame jambs, or stiles/rails of panel (not glass) to determine if bowed.

1. Cut piece of string slightly longer than height of frame or panel.
2. Pull tightly and stretch string to upper and lower corners of jambs, or, stiles or rails of panel. Tape securely.
3. Look for gap between string and frame or panel. If gap measures more than 1/4" at any point, the panel is bowed.

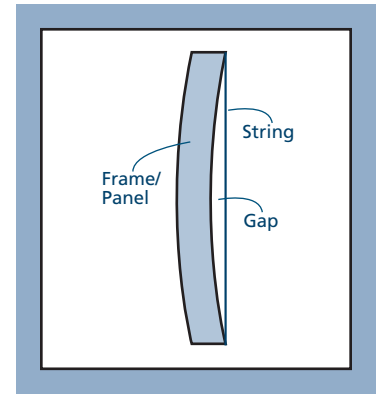

TROUBLESHOOTING OPERATIONAL PROBLEMS

Note! Please check each possible cause, including verifying proper installation, before contacting us for assistance.

PROBLEM	POSSIBLE CAUSES	POSSIBLE SOLUTIONS
Sash will not open	Sash locked	Make sure lock latch is in unlocked position, try again
	Obstructions	Remove obstructions/shipping blocks
	Sash damaged	Repair or replace sash
	Lock damaged or broken	Replace lock
	Keeper loose or damaged	Tighten if loose, replace if damaged
	Weatherstrip loose or damaged	Reattach if loose, replace if damaged
	Pivot pins damaged, misaligned, or missing	Re-align and/or replace if damaged or missing
	Balance damaged or broken	Remove sash and examine balance for damage. Replace if damaged.
Sash will not close	Improper installation	Inspect installation
	Sash locked	Make sure lock latch is in unlocked position, try again
	Obstructions	Remove obstructions/shipping blocks
	Pivot pins may not be properly engaged in the balance system	Remove and reinstall sash. Make sure pins are engaged properly.
	Keeper loose or damaged	Reattach if loose, replace if damaged
	Lock latch misaligned or damaged	Adjust if misaligned, replace if damaged
	Weatherstrip loose or damaged	Reattach if loose, replace if damaged
	Balance damaged	Remove sash and examine balance for damage. Replace if damaged.
	Pivot pins damaged or misaligned	Replace if damaged or re-align
	Sashes do not line up at check (meeting) rails/stiles	Make sure both sashes are completely closed. If rails/stiles do not meet correctly, call us for assistance
Sash binds or drags	Improper installation	Inspect installation
	Obstructions	Remove obstructions/shipping blocks
	Weatherstrip loose or damaged	Reattach if loose, replace if damaged
	Hardware loose, misaligned or damaged	Tighten loose hardware. Re-align if misaligned. Replace if damaged.
	Balance misaligned or damaged	Remove sash and examine balance. Re-align or replace if damaged.
	Pivot pins misaligned or damaged	Replace if damaged or re-align

TROUBLESHOOTING OPERATIONAL PROBLEMS - CONTINUED

PROBLEM	POSSIBLE CAUSES	POSSIBLE SOLUTIONS
Sash will not lock properly	Lock misaligned or damaged	Realign if misaligned, replace if damaged
	Sashes do not line up at check (meeting) rails/stiles	Make sure both sashes are completely closed. If rails/stiles do not meet correctly, call us for assistance
	Improper installation	Inspect installation
Sash will not stay up or down	Cam pivots (pivot pins) disengaged or damaged	Remove and reinstall sash. Replace cam pivots/pivot pins if damaged.
	Balance out of adjustment	Adjust balance (if applicable)
	Balance damaged	Remove sash and examine balance for damage. Replace if damaged.
	The balance could contain the wrong spring	Replace balance
	Improper installation	Inspect installation
Sash appears crooked in frame	Obstructions	Remove obstructions/shipping blocks
	Balance damaged	Remove sash and examine balance for damage. Replace if damaged.
	Improper installation	Inspect installation
The window surface fogs up	Condensation. See also our condensation document at: http://www.jeld-wen.com/_pdf/JGI012.pdf	<p>If condensation is on an interior surface:</p> <ul style="list-style-type: none"> • Raise the average temperature of the house one or two degrees and do not block vents. • Vent all appliances to the outdoors and run exhaust fans. • Open window blinds for air circulation. • Turn humidifiers down as the temperature gets colder (unless used for medical purposes). <p>If condensation is on an exterior surface:</p> <ul style="list-style-type: none"> • Close window coverings to reduce cooling of the glass surface by air-conditioning. • Remove or trim shrubbery close to windows to promote air circulation. <p>If condensation is between glass panes:</p> <ul style="list-style-type: none"> • Seal failure. Replace either the insulating glass assembly or the entire sash. This determination should be made by a service representative.
Water leaks through the window	Clogged weep system	Clean sill track with vacuum or damp cloth and pour small amount of water into interior sill track. If water doesn't drain out, inspect the exterior and clear any blockage. If not blocked, insert thin wire into weep hole (do not insert wire if the weep system has an exterior crevice). Repeat until water runs through weep hole.
	Weatherstrip damaged or missing	Reattach If loose, replace if damaged
	Sash damaged or loose at joints	Replace sash

GLOSSARY

Balance

The hardware in the side jamb of a single or double-hung window that is part of the system that allows the window to operate up and down.

Balance Shoe

A part of the balance system into which the pivot pin is inserted or engaged.

Double-Hung

A window with two sashes, upper and lower, that slide vertically past each other.

Jamb

The vertical frame members of a window or door assembly.

Keeper

A bracket utilized as a latching point.

Pivot pin

The pins on the bottom corners of single- and double-hung sash that engage the balance and also allow the sash to "pivot" for easy removal and reinstallation.

Sash

An assembly comprised of stiles (vertical pieces), rails (horizontal pieces) and the window's glass.

Score

To use a knife or an awl to scribe a line or make a notch in a material.

Single-Hung

A window with a fixed upper sash and movable lower sash that slides vertically.

Tilt Window

A double-hung window designed in such a way that the sashes tilt inward for easy cleaning of the outside of the glass.

Weatherstrip

A strip of material that covers the joint between two separate parts of a window or patio door and is used to prevent rain, snow, and cold air from entering.

Weep hole

The visible exit or entry part of a water drainage system used to drain water out of a window unit.