

# DHI Hoods



## 36", 42", 48", 54" and 60" Wide Ceiling Mount Island Hoods

## PLANNING GUIDE

### WARNING

- Observe all governing codes and ordinances during planning and installation. Contact your local building department for further information.
- This appliance must be installed in accordance with the accompanying installation instructions.
- DO NOT install an additional in-line or external blower to increase the length of the duct run. Even small differences between blower air flow rates can greatly reduce the air draw of the hood.

Blower	600 CFM* (1200 CFM* for units with 2 blowers) with electronic speed control
Blower Speeds	4
Lights	12 Vac, 20 Watt halogen
Filters	Baffle type, dishwasher safe
Exhaust	8 Inch
Finish	430 stainless steel
Total connected load	120 Vac, 60 Hz (see table at right for current rating)
Circuit requirements	120 Vac, 15 Amp. grounded, dedicated 3-wire circuit (hot, neutral, ground)

\* At zero inches static pressure

### GENERAL SPECIFICATIONS

Model	Blowers	Lights	Filters	Maximum Current Draw
DHI361	1	4	1	3.8 Amp.
DHI421	1	4	1	3.8 Amp.
DHI482	2	4	2	6.8 Amp.
DHI542	2	6	2	7.1 Amp.
DHI602	2	6	3	7.1 Amp.

### MODEL SPECIFIC SPECIFICATIONS

All tolerances:  $\pm 1/16"$  ( $\pm 1.6$  mm), -0, unless otherwise stated

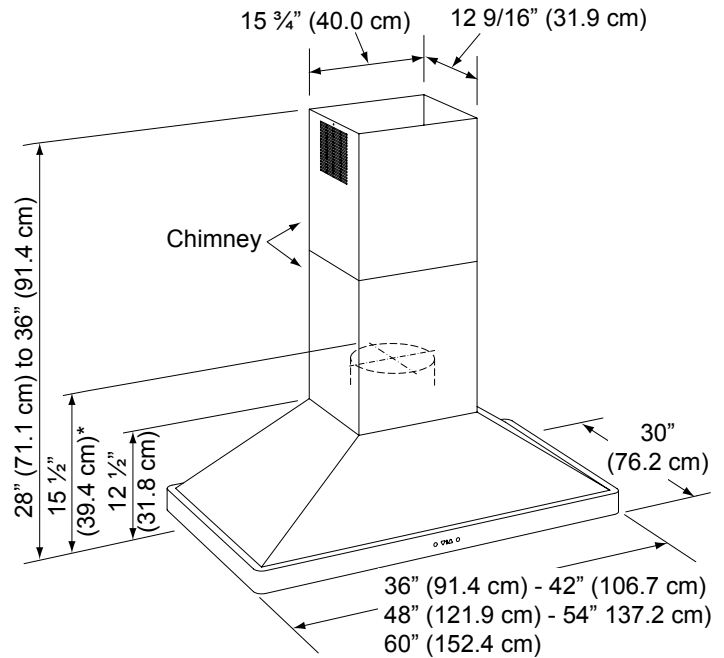

\* 18" 1/4 on models DHI482, DHI542 and DHI602

### DHI SERIES OVERALL DIMENSIONS

Chimney can accommodate up to 10" round duct work

### Maximum Duct Length

The maximum straight duct length for the hood is 50 feet. To determine the actual maximum duct run, subtract the equivalent length of each elbow, transition and cap from 50 feet. See the **Duct Planning Guide** or the installation instructions for more details.

**IMPORTANT:** The minimum installed distance from the hood to the cooking surface must be no less than 30 inches. The minimum specified distance may be higher for the particular range or cooktop in use. Check the manufacturers specifications for the cooktop or range.